

CX C-SERIES HYDRAULIC EXCAVATORS
CX210C | CX250C

CASE
CONSTRUCTION



TECHNOLOGY
YOU CAN TRUST

www.casece.com
EXPERTS FOR THE REAL WORLD
SINCE 1842

**TECHNOLOGY
YOU CAN TRUST**



CLEAN POWER

Case C Series excavators use clean and efficient Tier 4 interim diesel engines.

Equipped with cooled exhaust gas recirculation (CEGR) and a diesel particulate filter, the engine is capable of meeting emissions regulations without the need for additional diesel exhaust fluids.

Automatic self-regeneration of the diesel particulate diffuser (DPD) ensures no loss of productivity, while low engine rpm, improved hydraulic pump control and five new energy saving systems boost fuel economy by up to 10%.

A green economy gauge can be activated in the cab to inform the operator of the most economical operating mode setting for the machine, reporting fuel consumption in real-time.



CX C-SERIES HYDRAULIC EXCAVATORS



ADVANCED ENERGY MANAGEMENT

Through the use of 5 new fuel saving functions, C series excavators speed up productivity and substantially improve fuel economy. The new systems include:

Boom Economy Control (BEC)

Increased fuel efficiency during boom lower and swing operations.

Automatic Economy Control (AEC)

Improved fuel efficiency when servo joysticks are in neutral position and the operator is not calling for power from the machine.

Swing Relief Control (SWC)

Carefully manages the hydraulic power distribution at slewing operations, to provide the most efficient flow and pressure.

Spool Stroke Control (SSC)

Creates an automatic pressure adjustment during digging and leveling operations. It saves fuel, while improving controllability for the operator in fine digging operations.

Auto Energy Save (AES)

All C-series excavators also feature Auto Idle and Idle Shut Down systems. When activated, Auto Idle automatically lowers engine revs, whatever the throttle position, when the levers have been inactive for 5 seconds. Manually, Idle can be activated by a switch on the joystick. Idle shut down, when activated, shuts down the engine when there has been no activity for 3 minutes, resulting in additional fuel savings.





INCREASED PRODUCTIVITY

As part of the Case Intelligent Hydraulic System all Case C Series excavators benefit from improvements in performance and productivity.

Lifting capacity is increased and cycle times have been cut. Individual operating weights are slightly increased to cope with the additional digging and loading forces, ensuring stable, consistent high production.

Bucket and boom down regeneration systems feed hydraulic oil back to the supply side of the pump, reducing the requirement for engine power.

The C Series excavators use the familiar working mode control from the B Series machines, making it easy for the operator to become familiar with the new models. The H and SP Modes provide a 5% boost when required for maximum digging ability.

The new monitor in the C Series machines provides operators with the chance to pre-programme auxiliary hydraulic flow and pressure settings (option) for up to 10 attachments, providing rapid changeover and increased productivity.



CX C-SERIES HYDRAULIC EXCAVATORS



TIER 4 INTERIM: CLEAN AND EFFICIENT

The new Isuzu 4-cylinder engine meets EPA's Tier 4 interim without a need for additional diesel exhaust fluid. The cooled exhaust gas recirculation (CEGR) in dual layer design effectively reduces NOx while PM is reduced by a diesel particulate filter (DPF) in combination with the variable geometry turbocharger. A diesel oxidation catalyst (DOC) treats carbon monoxide, hydrocarbons and other compounds. Both components are integrated in the DPD (Diesel Particle Diffuser). Automatic self regeneration speeds your productivity - you can go on working as usual without stopping for the regeneration process of the particle diffuser. Side by side coolers, intercooler and the fuel cooler are now even more efficient thus further increasing our well appreciated durability.

A look under the hood immediately confirms an extremely efficient use of space: the engine, the cooling system and the exhaust system are all designed and grouped so as to take advantage of all the available space, while also granting excellent serviceability and operator visibility

An ECO gauge can be activated on the new multifunction screen to inform you instantly about the key parameters concerning fuel economy and fuel consumption. Low engine rpm in combination with further improved pump torque control and further 5 new energy saving systems reduces the fuel consumption further by up to 10%.



FIRST CLASS SERVICEABILITY

All filters and regular fill points are grouped for easy access, with engine oil change intervals set at 500 hours. A synthetic filter is used for the hydraulic oil, providing 5,000 hour intervals, and all pins and bushes (except the bucket pin) use the Case Extended Maintenance System bushings, allowing greasing intervals of up to 1,000 hours.

The radiator and cooler cores are mounted side by side, to allow easy access for cleaning and more efficient cooling.

The Japanese-built Case excavators boast an enviable reputation for reliability and durability, which looks set to continue with the new C Series of CX class crawler excavators.

CX C-SERIES HYDRAULIC EXCAVATORS



FIRST CLASS OPERATOR ENVIRONMENT

The C Series cab is 7% larger than the previous models and uses a smaller top beam and no overlap in the front windows to offer improved all round visibility. Noise levels are reduced to almost automotive standards, around 70dB(A), while the operator has a suspension seat and fully adjustable levers as standard. Travel pedals require less effort, reducing fatigue for the operator.

The ROPS/FOPS level 2 certified cab sits on new suspension mounts. To reduce vibration for the operator and contribute to the lower internal noise levels.

The cab has a powerful air conditioning system with 25% more airflow and an 8% increase in performance.

New mirrors and a standard rear view camera, with optional side camera, improved 7" LED monitor inside the cab, providing the operator with a safe and secure working environment.



FULL COLOUR MULTIFUNCTION MONITOR

The standard 7" LED monitor provides all of the information that the operator needs at a glance. Easy to use buttons guide the operator through the screen functions and the monitor can be split to show the standard rear view, and optional side view camera images.

Information includes working mode, travel speed, working lights, attachment choice, time and working hours, along with system data such as coolant and hydraulic oil temperatures, fuel level and the condition of the particulate filter and the auto-regeneration function.

When selected, the ECO gauge displays the function of the various energy saving systems, allowing the operator to maximise efficiency and save fuel.

The monitor can be set to work in one of 20 languages, and is also used by service technicians to access onboard diagnostic functions.



CX C-SERIES **HYDRAULIC EXCAVATORS**







THE CASE DEALER: YOUR PROFESSIONAL PARTNER

Your success starts with world-class Case machinery and attachments.

Your Case dealer will help you work smarter and faster by selecting equipment that delivers performance and operator comfort.

Your dealer has the knowledge and experience necessary to help you choose the right attachments so you can...

- **Work faster and extend equipment life.**
- **Increase machine utilization.**
- **Increase your capabilities.**

Let your Case dealer service your machine on the jobsite.

You'll be back on the job faster.

Advantages include...

- **Responsive job site service to keep your equipment running.**
- **Increase machine uptime.**
- **Certified service staff and improved parts availability.**



PARTS

When you're looking for superior parts options to maximize the performance and lower the operating costs of your Case machinery, turn to CNH Industrial Genuine Parts to keep you equipped for success.

CNH Industrial Genuine Parts fit better, install faster and last longer and in an industry where "high impact" and "heavy lifting" are the norm, the smallest mechanical differences can lead to big problems.

CNH Industrial Genuine Parts from Case are manufactured from superior materials and specifically designed for Case construction equipment to continually and reliably withstand the punishment of everyday construction. So steer clear of mechanical problems and future breakdowns, by choosing CNH Industrial Genuine Parts from Case. They're the only parts that are field-tested and proven to keep your Case equipment performing its best.

SERVICE. RELY ON CASE TO DELIVER FOR YOU

Your commitment to your operation is evident every day, but that doesn't minimize the enormous pressure you face to reduce operating costs and improve productivity. So when you're on the job, make sure you have top-notch service and support of Case behind you every step of the way.

With our factory trained technicians, you can ensure that top-notch service professionals are working on your maintenance needs, so you can focus on your business and the big job challenges ahead, not on the tasks of servicing your equipment.

With your Case Service, you get more than mere oil changes. A Case Service ensures your Case equipment receives a thorough service that meets all requirements of its service schedules and properly maintains it for the day-in, day-out punishment of construction work.

Don't give another thought to time-consuming maintenance tasks. Simply rest easy and make certain that your service needs are taken care of by a Case factory trained technician.

When the unexpected occurs, you need to know your equipment is protected.
At Case Construction we understand the importance of your machinery being in good working order when it counts.

ProCover is designed to help keep your equipment working well beyond the manufacturer's base warranty period while taking away the concerns of the cost and inconvenience of mechanical failure.

WHAT ARE THE ADVANTAGES OF PROCOVER?

PEACE OF MIND

Provides protection beyond the Manufacturer's Base Warranty Period.

FLEXIBLE OPTIONS

Plans can be customised to meet individual needs.

DEPENDABLE SERVICE

Eligible repairs completed by an authorised Case Construction Dealership and their trained service technician's using genuine OEM parts & lubricants.

TRANSFERABLE PROTECTION

New Equipment Plans may be transferred to a new owner at no charge

COVERAGE

- **STANDARD PROTECTION PLAN** **3 Years / 5000 Hours**
Additional years/hours can be purchased.
Please contact your local Case Construction dealer for further information.

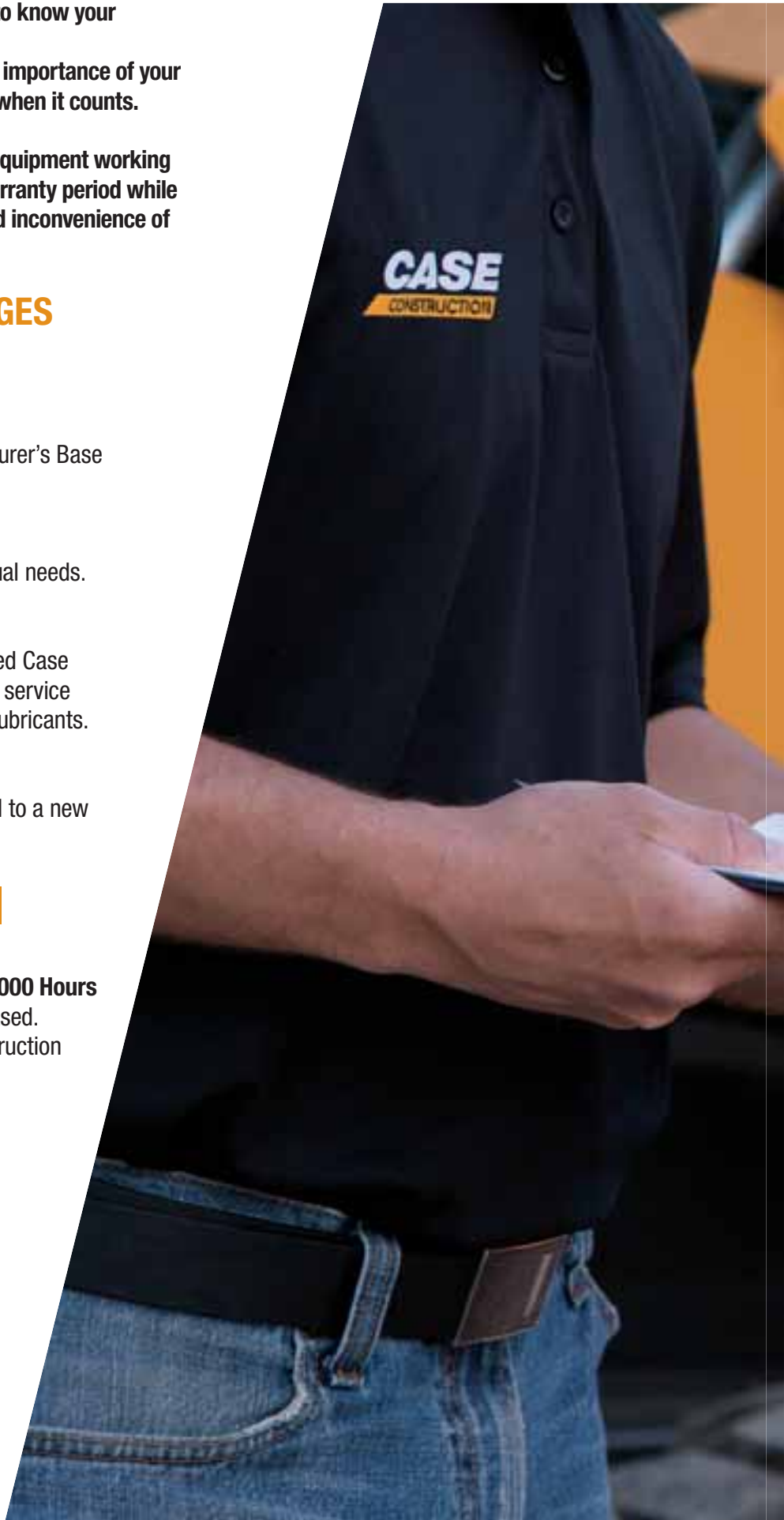

STANDARD PROCOVER PLUS PROTECTION PLAN

CONSTRUCTION EQUIPMENT MASTER PARTS SCHEDULE

This plan provides coverage for the components listed below when a failure occurs due to a defect in material or workmanship, and may provide coverage for additional components not listed when the damage is caused by or resulting from a covered failure of a listed component.

PREMIER COMPONENTS COVERED

ENGINE AND ALL INTERNAL LUBRICATED COMPONENTS WITHIN	TRANSMISSIONS/AXLES/HYDROSTATICS	ELECTRICAL	HYDRAULICS
Accessory Gears	Axle Housing	Alternator	Accumulator And Related Relief Valve
Air Intake Hose	Axle Shaft	Gauges	Brake Accumulator
Camshaft	Clutch Discs (Wet Only)	Horn	Brake Pressure Sensor
Camshaft Bearings	Clutch Plates (Wet Only)	Indicators	Brake Pump, Brake Valve
Camshaft Drive Gear	Control Rods	Instruments	Differential Lock Valve
Catalytic Converter	Counter Shaft Clutch	Electronic Joysticks	Fan Pumps And Motors
Charge Air Cooler	Differential Housing	Electric Motors	Hydraulic Cylinders
Cold Start Enrichment Systems	Differential Pinion Gear / Ring Gear	Factory Installed Telematics	Hydraulic Hoses and Piping
Connecting Rods & Bearings	Drive Axle Hub	Sensors	Hydraulic Motors
Crankshaft Bearings & Gear	Drive Shaft Support Bearing	Solenoid Valves	Hydraulic Oil Coolers
Crankshaft Including Front And Rear Crankshaft Seals	Drive Shaft with Universal Joints	Starter And Starter Solenoid	Hydraulic Pumps
Cylinder Heads/ Head Gaskets	Electronic Transmission Controller and Valve	Switches	Hydraulic Reservoir
Cylinder Liners	Enclosed Oil Immersed Chains and Sprockets	Traction Control System	Hydraulic Valves
Diesel Exhaust Fluid Tank and Dispensing System	External Oil Lines	Voltage Regulator	Internal O-Rings and Bonded Washers
Diesel Particulate Filter	Filler Tubes (Transmission)	Wiring Harnesses	Pilot Control
EGR System Manifold	Final Drive Pinion	Wiring Harnesses Exclusions	Pressure Reducing Valves
Electronic Engine Control Module	Final Drive Planetary Gears	Rubbing, Chafing, Loose Or Corroded Connections	Unloading Valves
Engine Block	Front Wheel Drive Sensors	FACTORY INSTALLED HEAT AND AIR CONDITIONING	STRUCTURAL
Engine Mounts And Supports	Hydraulic Drive / Travel Motor	Accumulator	Backhoe Booms
Engine Oil Cooler	Hydraulic Drive Pump	Clutch	Backhoe/Excavator Dipper Sticks
Engine Speed Controls, Linkages, and Cables	Hydraulic Transmission-Control Valve	Compressor	C Frame
Exhaust Manifold and Muffler	Hydrostatic Motor	Condenser	Car Body
Fan And Fan Drive	Hydrostatic Transmission Charge Pump	Dryer	Chassis
Filter Mount	Hydrostatic Transmission Pump	Evaporator	Circle Frame
Flywheel, Ring Gear	Hydrostatic/Hydraulic Pump Drives	Expansion Valve	Engine Frame
Front And Rear Engine Covers And Seals	Internal Lubricated Clutch Housings	Heater Core	Equipment Frame
Front Damper	Internal Transmission Control Linkage	Hoses	Excavator Booms
Fuel Lines	Internal Wet Service Brakes	Pulley	Falling Object Protection Structure (FOPS)
Fuel Tank	MFWD Axle/Differential Assembly including Driveshaft and U Joint	Seals & Gaskets	Forklift Masts
Fuel Transfer Pump & Gasket	Planetary Gear Carrier	Temperature Control Programmers and Valves	Inner and Outer Dipper Arms of the Extendable Boom (Backhoe Loader)
Injection Pump	Pneumatic Valves	OPERATOR AREA	Main Frame
Injectors	Rotary Hydraulic Manifold	Covers and Panels	Rollover Protection Structure (ROPS)
Intake and Exhaust Manifold And Gaskets	Splitter Drive/Drop Box	Exterior/Interior Door/Panel Latches, Hinges & Struts	Swing Frame
Oil Filler Tube	Steering Clutches (Wet)	Exterior/Interior Moldings	Swing Tower Castings (Backhoe Loader)
Oil Lines	Swing Motor And Swing Gear Box	Knobs for Switches and Handles	Track Frame
Oil Pan And Gasket	Torque Converter	Mirrors	Wheel Loader/Skid steer Loader Arms
Oil Pump	Torque Converter Pump	Seat Frame & Suspension	
Pistons & Rings	Transfer Drive		
Pre-Cleaner/Air Cleaner Housing	Transmission Case		
Pressure/Temperature Sensors & Sending Units	Transmission Gears, Bearings, & Shafts		
Pulleys	Transmission Pump		
Radiator	Travel & Swing Sections (only) Of Main Control Valve		
Rocker Arm Assembly	Travel Control Valve		
Selective Catalytic Reduction System	Turntable Bearing		
Thermostats	Undercarriage Roller And Idler Seals And Bearings		
Timing Gears	Undercarriage Tensioners		
Turbocharger And Gasket	UNDERCARRIAGE EXCLUSIONS:		
Valve Cover And Gasket	Sprocket, Tracks, Pads, Bolts, Chains, Or Any Failure Due To Wear, Or Breakage Caused By Wear		
Water Piping			
Water Pumps			

CX C-SERIES

HYDRAULIC EXCAVATORS

ENGINE

Model _____ ISUZU AM-4HK1X
 Type _____ Water-cooled, 4-cycle diesel, 4-cylinder in line,
 Electronically controlled, high pressure common rail system, variable
 geometry turbocharger, air cooled intercooler, dual exhaust gas recirculation,
 DPD system with auto-regeneration. Tier 4 interim certified.
 Number of cylinders/displacement _____ 4/5.19 l
 Bore/Stroke _____ 115 x 125 mm
 Horsepower ISO 9249 _____ 119 kW/160 hp at 1800 min⁻¹
 Maximum torque ISO 9249 _____ 621 Nm at 1500 min⁻¹

HYDRAULIC SYSTEM

Max oil flow _____ 2 x 211 l/min @ 1800 min⁻¹
 2 variable displacement axial piston pumps with regulating system
 Working circuit pressure _____
 Boom/Arm/Bucket _____ 34.3 MPa
 Boom/Arm/Bucket (with auto power up) _____ 36.8 MPa
 Swing circuit _____ 29.4 MPa
 Travel _____ 34.3 MPa

SWING

Maximum swing speed _____ 11.5 min⁻¹

TRAVEL

Travel motor _____ Variable displacement axial piston motor
 Max travel speed _____ 5.6 km/h (Automatic travel speed shifting)
 Low travel speed _____ 3.4 km/h
 Gradeability _____ 70% (35°)
 Drawbar pull _____ 188 kN

ELECTRICAL SYSTEM

Circuit _____ 24V
 Alternator _____ 50 Amp

UNDERCARRIAGE

Number of carriers rollers (each side) _____ 2
 Number of track rollers (each side) _____ 8
 Number of shoes (each side) _____ 49
 Type of shoe _____ Triple grouser shoe

CAPACITIES

Fuel tank _____ 410 l
 Hydraulic system _____ 240 l
 Cooling system _____ 30.8 l

WEIGHT

With 2.94 m Arm, 0.8 m³ bucket, operator, lubricant, coolant, full fuel tank and top guard OPG level 2

CX210C LC	WEIGHT (kg)
500 mm grouser shoe	20,940

SPECIFICATIONS

CX210C

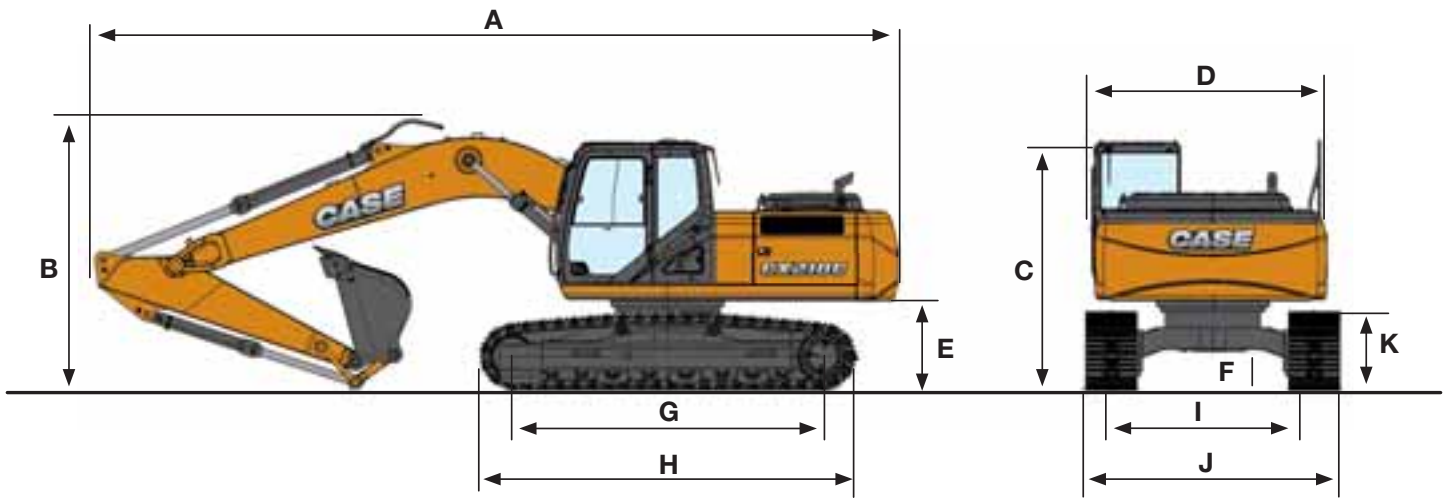

GENERAL DIMENSIONS

CX210C LC

ARM 2.94 m

	Overall length (without attachment)	4960 mm
A	Overall length (with attachment)	9380 mm
B	Overall height (with attachment)	3000 mm
C	Cab height	3070 mm
D	Upper structure overall width	2770 mm
	Swing (rear end) radius	2750 mm
E	Clearance height under upper structure	1040 mm
F	Minimum ground clearance	440 mm
G	Wheel base (Center to center of wheels)	3660 mm
H	Crawler overall length	4470 mm
I	Track gauge	2390 mm
J	Undercarriage overall width (with 600 mm shoes)	2990 mm
K	Crawler tracks height	920 mm

CX C-SERIES HYDRAULIC EXCAVATORS

PERFORMANCE DATA

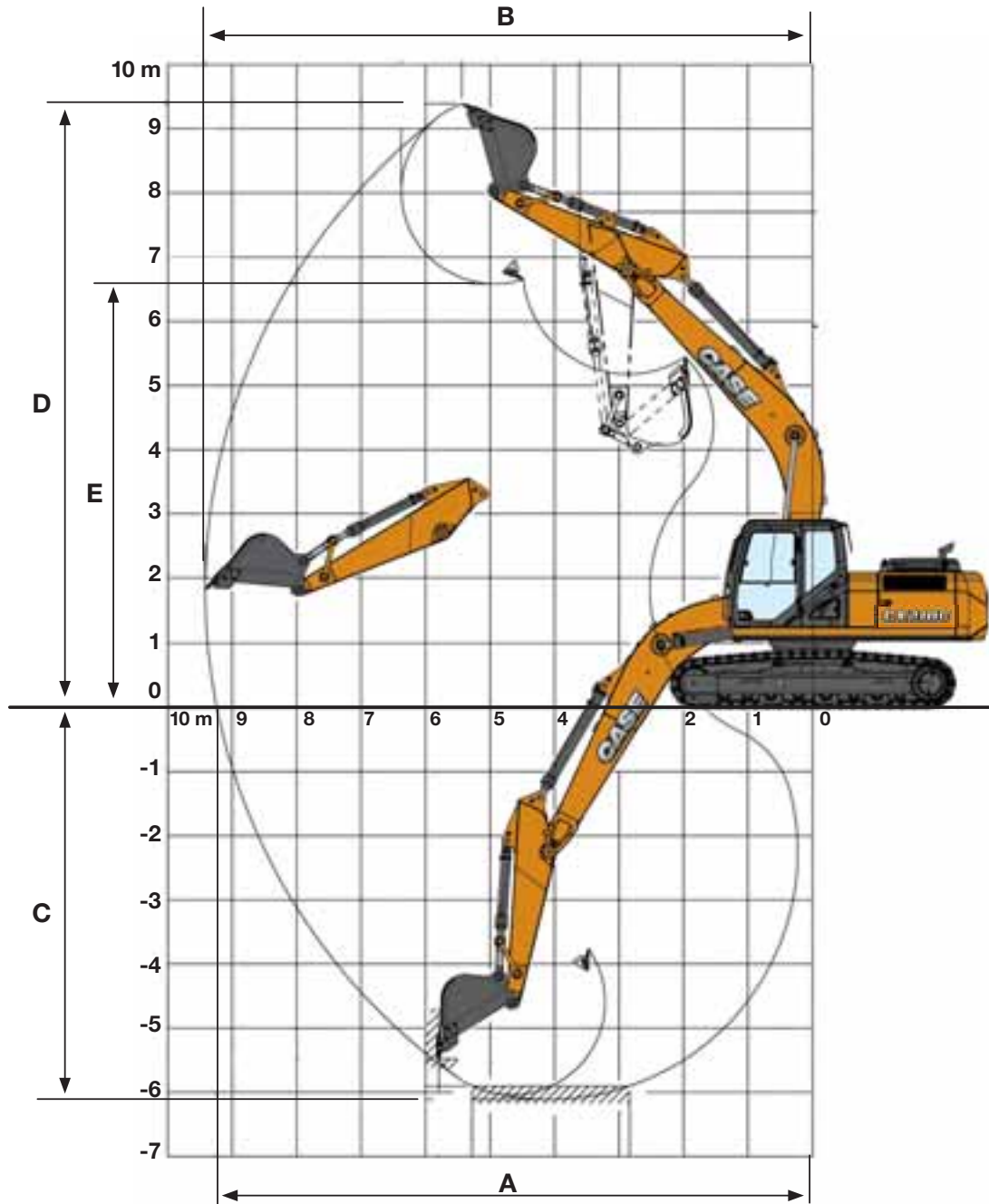

CX210C LC

ARM 2.94 m

	Boom length	5700 mm
	Bucket radius	1450 mm
	Bucket wrist action	177°
A	Maximum reach at GRP	9730 mm
B	Maximum reach	9900 mm
C	Max. digging depth	6650 mm
D	Max. digging height	9610 mm
E	Max. dumping height	6810 mm

LIFTING CAPACITY

CX210C

DIGGING FORCE

With 1.0 m³ bucket (ISO 6015)

CX210C LC	ARM 2.94 m
Arm digging force	103 kN
- with auto power boost	110 kN
Bucket digging force	142 kN
- with auto power boost	152 kN

Front 360°	REACH						
	0 m	1.5 m	3.0 m	4.5 m	6.0 m	7.5 m	At max reach m

Standard arm. 2.94 m arm length, 0.80 m³ bucket, 600G LC shoes, max reach 9.56 m

7.5 m									2970*	2970*			2190*	2190*	7,76	
6.0 m									3750*	3500			2080*	2080*	8,71	
4.5 m								4630*	4630*	4290*	3380	3140*	2370	2070*	2070*	9,28
3.0 m			9870*	9870*	7400*	7300*	5690*	4720	4760*	3230	3640	2300	2140*	2040	9,54	
1.5 m			9250*	9250*	9160*	6890	6620*	4410	4840	3070	3550	2220	2280*	1990	9,53	
0 m			8340*	8340*	10170*	6440	6710	4170	4690	2930	3490	2160	2520*	2050	9,28	
-1.5 m	6960*	6960*	10500*	10500*	10360*	6290	6560	4030	4610	2860			2940*	2240	8,76	
-3.0 m	9520*	9520*	14210*	12790	10090*	6360	6590	4080	4690	2930			3700*	2650	7,95	
-4.5 m	13390*	13390*	13170*	12830	9040*	6580	6490*	4320					5220*	3450	6,79	

* Lift capacities are taken in accordance with SAE J1097 / ISO 10567 / DIN 15019-2

Lift capacities shown in kg do not exceed 75% of the tipping load or 87% of the hydraulic lift capacity

Capacities that are marked with an asterisk (*) are hydraulic limited

If the machine is equipped with a quick coupler, subtract the weight of the quick coupler from the load shown in the table to calculate the real lift capacity

CX C-SERIES

HYDRAULIC EXCAVATORS

ENGINE

Model _____ ISUZU AL-4HK1X
Type _____ Water-cooled, 4-cycle diesel, 4-cylinder in line,
Electronically controlled, high pressure common rail system, variable
geometry turbocharger, air cooled intercooler, dual exhaust gas recirculation,
DPD system with auto-regeneration. Tier 4 interim certified.
Number of cylinders/displacement _____ 4/5.19 l
Bore/Stroke _____ 115 x 125 mm
Horsepower 80/1269/EEC _____ 132 kw @ 2000 min-1
Maximum torque 80/1269/EEC _____ 621 Nm @ 1800 min-1

HYDRAULIC SYSTEM

Max oil flow _____ 2 x 234 l/min @ 2000 min-1
2 variable displacement axial piston pumps with regulating system
Boom/Arm/Bucket _____ 36.8 MPa
Swing circuit _____ 27/28.9 MPa
Travel _____ 34.3 Mpa

SWING

Maximum swing speed _____ 10.6 rpm

TRAVEL

Travel motor _____ Variable displacement axial piston motor
Max travel speed _____ 5.5 km/h (Automatic travel speed shifting)
Low travel speed _____ 3.5 km/h
Gradeability _____ 70% (35°)
Drawbar pull _____ 201 kN

WEIGHT

With 3.00 m Arm, 1.0 m³ bucket, operator, lubricant, coolant, full fuel tank and top guard OPG level 2

CX250C LC	WEIGHT (kg)
600 mm grouser shoe	24,600

ELECTRICAL SYSTEM

Circuit _____ 24V
Alternator _____ 50 Amp

UNDERCARRIAGE

Number of carriers rollers (each side) _____ 2
Number of track rollers (each side) _____ 9
Number of shoes (each side) _____ 51
Type of shoe _____ Triple grouser shoe

CIRCUIT AND COMPONENT CAPACITIES

Fuel tank _____ 410 l
Hydraulic system _____ 250 l
Cooling system _____ 30.2 l

SPECIFICATIONS

CX250C

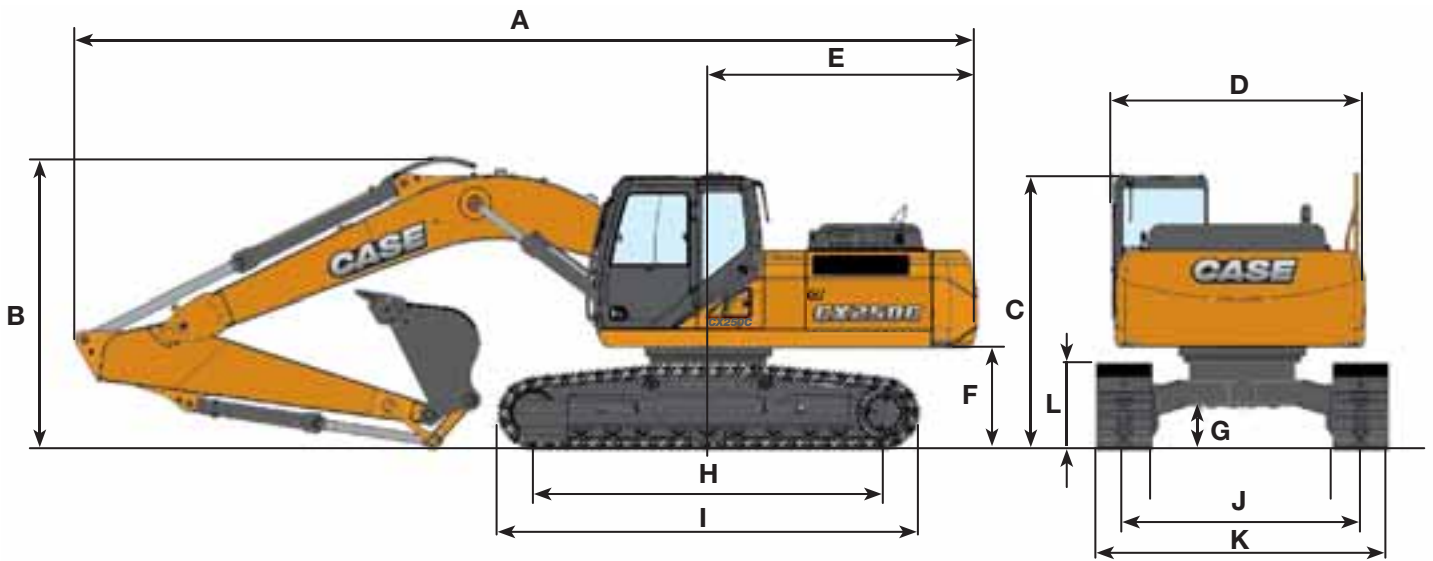

GENERAL DIMENSIONS

With 5.85 m standard boom

CX250C LC

ARM 3.00 m

	Overall length (without attachment)	5270 mm
A	Overall length (with attachment)	9880 mm
B	Overall height (with attachment)	3200 mm
C	Cab height	3130 mm
D	Upper structure overall width	2770 mm
E	Swing (rear end radius)	2950 mm
F	Clearance height under upper structure	1100 mm
G	Minimum ground clearance	460 mm
H	Wheel base (Center to center of wheels)	3840 mm
I	Crawler overall length	4650 mm
L	Crawler tracks height	940 mm
J	Track gauge	2590 mm
K	Undercarriage overall width (with 600 mm shoes)	3190 mm

CX C-SERIES HYDRAULIC EXCAVATORS

PERFORMANCE DATA

With 5.85 m standard boom

CX250C LC		ARM 3.00 m
	Boom length	5850 mm
	Bucket radius	1570 mm
	Bucket wrist action	175°
A	Maximum reach at GRP	10100 mm
B	Maximum reach	10280 mm
C	Max. digging depth	6900 mm
D	Max. digging height	9760 mm
E	Max. dumping height	6760 mm
	Arm digging force	120 kN
	- with auto power up	129 kN
	Bucket digging force	162 kN
	- with auto power up	174 kN

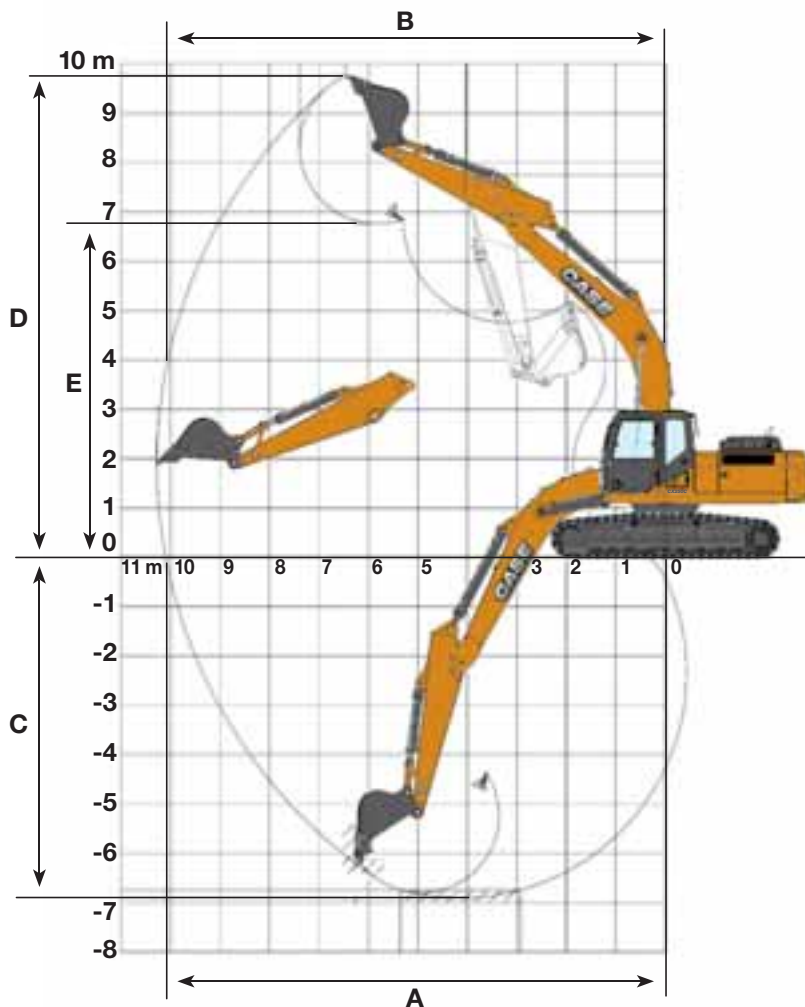

LIFTING CAPACITY

Front 360°	REACH						
	1.5 m	3.0 m	4.5 m	6.0 m	7.5 m	9.0 m	At max reach m

LC - Standard arm. 3.0 m arm length, 1.00 m³ bucket, 600G shoes, max reach 9.92 m

7.5 m									4150 *	4150					8,23
6.0 m									4780 *	4600	2830*	2830*	2250*	2250*	9,12
4.5 m						6110 *	6110 *	5570 *	4440	4470*	3150	2230*	2230*		9,66
3.0 m			13290 *	13290 *	9620*	9590*	7370 *	6170	6200 *	4240	4630	3050	2300*	2300*	9,9
1.5 m			9400 *	9400 *	11880*	9060	8540	5780	6130	4030	4520	2940	2430*	2430*	9,89
0 m			9260 *	9260 *	13110	8510	8530	5470	5940	3860	4420	2860	2670*	2550	9,64
-1.5 m	8890 *	8890 *	11810*1	1810 *	13290*	8340	8350	5310	5840	3770	4160*	2850	3070*	2780	9,13
-3.0 m	10960 *	10960 *	15870*	15870 *	12920*	8410	8380	5350	5910	3840			3770*	3240	8,34
-4.5 m	15110 *	15110 *	16790*	16790 *	11600*	8650	8400	5580					5200*	4170	7,18
-6.0 m			12060 *	12060 *	8290*	8290*							5910*	5910*	5,44

* Lift capacities are taken in accordance with SAE J1097 / ISO 10567 / DIN 15019-2

Lift capacities shown in kg do not exceed 75% of the tipping load or 87% of the hydraulic lift capacity

Capacities that are marked with an asterisk (*) are hydraulic limited

If the machine is equipped with a quick coupler, subtract the weight of the quick coupler from the load shown in the table to calculate the real lift capacity

SPECIFICATIONS

CX250C





CASE CONSTRUCTION EQUIPMENT
CONTACT INFORMATION
AUSTRALIA
31-53 Kurrajong Road
St. Marys nsw 2760

CASE Customer Assistance
1300 99 CASE

NOTE: CASE provides specific outfits for various countries and many optional fittings (OPT). The illustrations on this or other leaflets may relate to standard or optional fittings. Please consult your CASE dealer for any information in this regard and any possible updating on components. CNH Industrial reserves the right to modify machine specifications without incurring any obligation relating to such changes.

