

AWM4
Australian Imperial Force unit war diaries,
1914-18 War

Tunnelling & Survey

Item number: 16/2/23

Title: 1st Australian Tunnelling Company

November 1918



AWM4-16/2/23

354

CONFIDENTIAL.

ORIGINAL.

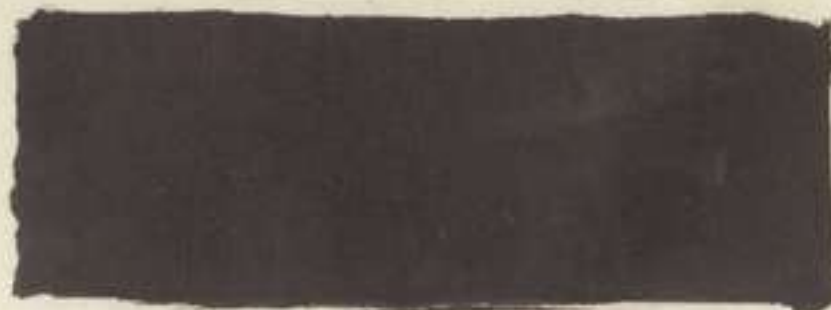

Australian Imperial Force.

WAR DIARY

OF

1st Australian Tunnelling Company

FOR

November 1918.

Signature of Officer compiling

W. J. W. Snow
Capt AE

Signature of Officer Commanding

C. S. Hudson, Major R.E.

November 1918.

WAR DIARY

Army Form C. 2118.

Instructions regarding War Diaries and Intelligence Summaries are contained in F. S. Regs., Part II. and the Staff Manual respectively. Title pages will be prepared in manuscript.

INTELLIGENCE SUMMARY.

(Erase heading not required.)

1st Australian Tunnelling Company

354

Place	Date	Hour	Summary of Events and Information	Remarks and references to Appendices
Busigny	1		Fine and cold.	
Sh. 57 ^B	2		Cold & wet	
V. 21. d. 8. 6.	3		Cold & fine N ^o 2 Section Advance. H.Q. moved to St Souplet Sh. 57 ^B Q 33 b. 2. 6. N ^o 3 Section Advance H.Q. moved to Sh 57 ^B W. 6. a. 7. 2. 25 men under L ^t Thompson N ^o 1 Section attached to Capt. Woodward in connection with bridging the Sambre Canal. N ^o 4 section Advance H.Q. to La Vallee Mulatre	4 2
	4		Fine & cold - stunt started Road report centre opened at Molain Bridge N ^o 1 Capt. Woodward & party successfully constructed Tank Bridge over canal at S.I. d. 3. 4. Sh 57 ^A under heavy enemy fire with casualties of 4 killed & 5 wounded. Parties under T. Capt Yates & Capt. Hinder accomplished very useful work in locating numbers of mines and traps of all descriptions. N ^o 3 section moved to X. 4. d. 8. 8. Sh 57 ^B .	2
	5		Raining and cold N ^o 1 Section working on road each side of bridge at S.I. d. 3. 4 Sh 57 ^A Rations very scarce owing to railway communication being delayed by a series of Delay Action Mines destroying the permanent way in the vicinity of Bohain & Fresnoy	
	6		Raining & Cold. N ^o 2 section returned to H.Q. after searching for mines etc. on the front of the 32 nd Division in the area of Ors - Landreucies - Favril.	
	7		Wet & cold N ^o 3 section moved forward to. N. 23 b. 6. 4. Sh 57 ^A & continuing searching for mines etc. on the front of the 46 th Division with satisfactory results.	
	8		Wet & cold	
	9		Fine & Cold	
	10		Fine & Cold N ^o 3 Sec moved to Q 12 b. 9. 1 Sh 57 ^A Sains-du-Nord. about 26 miles from Coy H.Q.	Direct

D. D. & L., London, E.C. (A8004) Wt. W1771/M2031 750,000 5/17 Sch. 82 Forms/Cz. 16/14

9 November 1918.

Instructions regarding War Diaries and Intelligence Summaries are contained in F. S. Regs., Part II. and the Staff Manual respectively. Title pages will be prepared in manuscript.

WAR DIARY

Army Form C. 2118.

INTELLIGENCE SUMMARY.

(Erase heading not required.)

1st Australian Tunnelling Company.

354

Place	Date	Hour	Summary of Events and Information	Remarks and references to Appendices
Busigny Sh 57 ^B V. 21. d. 8. 6	11 12 13		Fine & Cold. Lt. Bate & Irving to England on leave. Armistice signed with Germany 11.00 hours Fine & Cold. No 3 Section Moved to R. 14 a. 34. Sh. 57 ^A Fine & Cold. Sections searching with aid of German Plans & information for Delayed Action Mines	
	14 15		Fine & Cold. All sections moved to vicinity of H.Q. pending movement of Company Fine & Cold. Company Received orders to accompany 9th Corps. in March to the Rhine	
Avesnelles K. 25. a. 8. 2 Sh. 57 ^A	16		Fine & Cold. H.Q. No 1 & 4 section moved forward to K. 25. a. 8. 2 Sh. 62 ^A (Avesnelles.) 25 Q.R. from whole company remained behind being unable to march to the Rhine.	
Felleries K. 25 a. 8. 2 Sh. 57 ^A	17		Fine, dull & mild. H.Q. moved to Felleries Sh. 57 ^A L. 1. d. 8. 2. where they were joined by Sections 2 & 3. No 1 Section, ^{moved to} Montbliart (Belgium) where they became attached to 199 Infantry Brigade 66th Division & then led the right wing of the 9th Corps on the march. Rance being reached for the night. No 4 section moved to Chatcau Hestrued (N.W. Europe Sh. 4. 4. K. 2. 7.) which was the point of assembly for the left flank of 9th Corps. They were then attached to 1st Infantry Brigade 1st Division & led the column forward to Beaumont. The task allotted to these two sections was to lead the Corps. in case of mines or traps being found in billets ect. H.Q. & Sections 2 & 3. marching with "B" Column on the right wing flank.	
Montbliart (Belgium) H. 18 c. 1. 1. Sh. 57.	18		H.Q. No 2 & 3 sections marched to Montbliart H. 18. c. 1. 1. Sh. 57. Cold & light snow remained at No 1 Section marched to Certontaine Sh. 55 ^A E. 20 b. 3. 3. No 2 Squad No 4 Section. marched to Beaumont whilst remainder of No 4 section marched with column to Thuilles where several mines were located & unloaded from under bridges & culverts.	

D. D. & L., London, E.C.
(A8004) Wt. W1771/M2031 750,000 5/17 Sch. 52 Forms/C2.16/14

November 1918

WAR DIARY

Army Form C. 2118.

Instructions regarding War Diaries and Intelligence Summaries are contained in F. S. Regs., Part II. and the Staff Manual respectively. Title pages will be prepared in manuscript.

INTELLIGENCE SUMMARY.

(Erase heading not required.)

354

Place	Date	Hour	Summary of Events and Information	Remarks and references to Appendices
Cerfontaine Sh 57. E 14 central.	19		Cold & wet - H.Q. & No 2 & 3 Sections marched to Cerfontaine No 1 Section remained at Cerfontaine being unable to continue march owing to lack of transport	
	20		No 1, 3 & 4 squads of No 4 section marched to Walcourt & No 2 squad from Beaumont to Walcourt	
	21		No 4 section marched to Yves Gomezee Namur Sh 8 4 G. 00. 85 - Weather fine & Cold	
	22		Fine & cold with light frost	
	23		Fine & mild. All sections at work searching for & unloading mines	
Chanmont Namur Sh. 8 4 H. 30. 70	24		Fine & cold. No 4 section marched from Yves Gomezee to Corenne Namur Sh 8 3 I. 15. 05 roads & bridges examined on route for mines & traps	
	25		Fine & cold with heavy frost. H.Q. H.Q. No 1, 3 & P+2 Section marched to Chanmont Lt Bonar & 210.R. moved to L'Ecrivisse 4. B. 40. 30 for work.	
	26		No. 4 section marched to Rostenne near the Meuse R. (Namur Sh. 8.) 3 K. 45. 30 roads & bridges examined on route for mines & traps	
	27		Wet & Cold. opportunity taken to visit Charleroi 75 men making the trip by lorries	
Marbaix Namur Sh. 8 3. E. 48. 95	28		Dull & Cold. a further party of 75 men by lorries to Charleroi for the day men remaining at Chanmont examining railways for mines & traps & repairing roads	
			Dull & cold with light rain	
			Dull & cold steady rain. H.Q. Nos 1, 2 & 3 sections marched to Marbaix preparatory to being transferred to Australian Corps	
			No. 4 section marched from Rostenne to Marbaix being withdrawn from 1st Div. 9th Corps	

November 1918

WAR DIARY

4 Army Form C. 2118.

354

Instructions regarding War Diaries and Intelligence
Summaries are contained in F. S. Regs., Part II.
and the Staff Manual respectively. Title pages
will be prepared in manuscript.

INTELLIGENCE SUMMARY.

(Erase heading not required.)

Place	Date	Hour	Summary of Events and Information	Remarks and references to Appendices
Marbaix Namur Sh B 3E.48.95.	29		Dull & cold. Whole company transferred from 1x Corps to Australian Corps Lt. Bonar & party rejoined unit from L'Ecrivisse work having been completed	4
	30.		Dull & cold. All sections posted for work on unloading & removing enemy mines & traps which are considerable in this area. No. 3 section moved to Hestrud Namur Sh B 4.B. 85. 42. for Quarrying stone metal. No. 1 section moved to vicinity of Chatalet Namur Sh. B. 2 G. 35. 85. for reconnaissance of district for D. A. Mines & removal of charges No. 2 section investigating shafts near Stree. No. 4 section moved to. Namur Sh. B. 2E. 80. 87 Marchienne-au-Pont for reconnaissance of district for D. A. Mines & removal of charges	4

WAR DIARY

OF

1ST AUSTRALIAN TUNNELLING COMPANY A.E.

FOR

NOVEMBER

1918

LIST OF APPENDICES.

No.	Subject.
✓ 1.	Company and Special Orders
✓ 2.	Weekly and Special Company Reports.
✓ 3.	Casualties and Sick
✓ 4.	General Information and Communications from Higher Authority.
✓ 5.	Officers and Other Ranks to Instructional Schools.
✓ 6.	Letters of Appreciation from Higher Authority.
✓ 7.	Information re. Enemy Mines.
✓ 8.	Company Work Orders.

354

OPERATION ORDER

By

Major E.S. Anderson, M.C.
Commanding 1st Australian Tunnelling Company

Headquarters
2-11-18

In connection with C.R.E. C.T. Order No. R/57 of 31-10-18 and the work order issued on 2-11-18 the following instructions will be followed.

1. At least one quarter of section strength and all Headquarters Details will be left at Section Headquarters.
2. Exact location of Advanced Section Headquarters is to be reported to Company Headquarters.
3. Copy of all work reports to C.R.E. are to be sent daily to Company Headquarters by D.R. who will leave Company Report Centre at 10.00, 13.00, 16.00
4. Company Report Centre will be established at MOLAIN BRIDGE No. 1. (W.I.O.C.4.3.) with two D.R's at 8 a.m. 4-11-18.
5. Special and urgent messages from sections will be sent in at once.
6. Transport and rations will be arranged as requisitioned from this Headquarters.

Eugene Brown

Captain, AM.

APPENDIX

354

APPENDIX N.º 1.

COMPANY ORDERS

By
Major E.S. Andersen, M.C.
Commanding 1st Australian Tunnelling Company

1st AUSTRALIAN TUNNELLING COMPANY.	
No.	1130
Date	

2

Headquarters
3-11-18

Orders for 4-11-18

BATHS .

Baths for Corps Troops will open at 18B Rue HARNESSE
BUSIGNY on 3rd November.
Capacity 120 per hour.
Arrangements for the use of baths to be made with
the Corps Baths Officer.

FALLEN .
AIRCRAFT.

The attention of all ranks is drawn to the necessity of
preventing the removal of any part of the structure or
equipment of fallen aircraft.
In the event of any enemy aircraft coming down, unless
action has already been taken by another unit a sentry
will be mounted, a report forwarded to the nearest signals
for transmission to 9th Squad R.A.F. at 62B/C.I.O.b.2.7.
and report rendered through this Headquarters to
H.Q. R.A.F. giving the map Square of the fallen aircraft
and number and condition of occupants.

W. J. Anderson

Captain, A.E.

354

APPENDIX

APPENDIX N^o 1.

3

COMPANY ORDERS
BY

Major H. S. Andersen, M.C.
Commanding 1st Australian Tunnelling Coy.

Headquarters
4-11-18

ORDERS for 4-11-18

1. DAMAGE TO TREES.

As the country in advance of the present area in which horse lines are situated, has many valuable orchards, the following order is republished. Great care is to be exercised to prevent any unnecessary damage to trees, and to ensure that this order is complied with :-
"When the occupation of orchards, etc., by mounted troops is necessary, horses will on no account be tied to trees; and care must be taken to tether them, whenever possible, out of reach of any trees. Cases have occurred where the trunks of trees have been barked all round by horses being tied to them or by the horses themselves eating the bark, with the result that the trees perish. To prevent them from such injury, sacking or some similar material will invariably be wrapped round the trunks."

H. S. Andersen

Capt. AM.

COMPANY ORDERS

BY

Major H.S. Andersen, M.C.
Commanding 1st Australian Tunnelling Company

Headquarters
6-11-18

ORDERS FOR 7-11-18

1. BURIALS.

Corps R.O. 422 of 8-10-18 is republished for the information of all concerned :-
"Bomb traps have been recently found under the bodies of dead Germans. The bomb is usually placed under the head or neck of the body in such a manner that when the body is lifted the bomb explodes.
"Burial parties will in future be provided with a length of rope; this will be tied to the feet of the German dead", and the body dragged a few yards from where it is lying "before being lifted on to stretcher for burial"

2. BURIAL OF ANIMALS

The C.O. every Unit or detachment is responsible for the burial of any dead animal lying within 40 yards of the mess billets or bivouacs, if occupied by them for 24 hours or more. This order will be repeated to all concerned.

3. APP. INTMENT.

Lieut. S.J. Sawyer to be Acting Adjutant and Q.M. in accordance with increased establishment. A.I.F. Order No. No. 1392 as from 26-9-18, and to take up his duties at a later date.

4. SPECIAL ORDER

Attention is drawn to special order issued 6-11-18.

W.S.

Captain, AM.

NOTICE.

INDIAN ARMY.

Circular from DAG, AIF with reference to Admission of M.C.O's and men to Indian Training College, QUETTA may be seen at the orderly Room.

354

SPECIAL ORDER OF THE DAY

By

Major H. S. Andersen, M.C.
Commanding 1st Australian Tunneling Company

Headquarters
6-11-18

The following special order of the Day issued by Major General H. S. Strickland C.B., C.M.G., D.S.O. Commanding 1st Division is published for the information of all ranks :-

The task that the Division was called on to perform yesterday was one entailing the utmost forethought for every detail, the most careful and precise staff work in all branches, a thorough and precise organisation in B.M. of the most minute detail, and gallantry, tenacity and endurance on the part of all troops engaged.

The complete success of the operations is very greatly due to the skill, ability, rapidity and completeness with which the bridging arrangements were completed and perfected. I wish to pay special tribute to Lieut. Col. C. S. S. SANKAY D.S.O. his Field Company Commanders, and all ranks of the D.S.O. and Section 1st Australian Tunneling Company, A.S. for the part they have played in these operations. The cool gallantry with which they placed the bridges in position under heavy fire after long and arduous hours of labour, was magnificent. After this severe ordeal they were engaged for the rest of the day in bridge building under fire, without which the operations could not have been completed.

They have very worthily upheld the very high traditions of the Royal Engineers.

I cannot sufficiently express my admiration and thanks to all branches of the staff and to all units in the Division for their unsurpassed efforts of the last three weeks, culminating in as fine a military achievement as any troops could have carried out.

The Division as a whole, has every reason to be more than proud of their record, and they could not have done more than uphold, as they have done, the brilliant records of the First Division of the British Army.

(SIGNED) H. S. STRICKLAND Major General,
Commanding 1st Division.

The Commanding Officer wishes to place on the records of the Company the very gallant conduct of No. 4 Section and Detachment from No. 1 Section who were entrusted with the construction of the Heavy Tank Bridge over the OISE-SAMBRE Canal in the face of the enemy. The whole section under command of Capt. Woodward displayed such devotion to duty and disregard of personal risk that the bridge was successfully built and traffic enabled to pass five hours after zero. The Higher Commands have complimented the C.O. on this gallant feat of his unit, he therefore wishes those who actually took part in the operation to know that they, not only have won the admiration of other arms of the service but have added another laurel to the Company's records.

H. S. Andersen Major ^{AE}

COMPANY ORDERS

By

Major E.S. Andersen, M.C.
 Commanding 1st Australian Tunnelling Company

Headquarters
 In the Field
 8-11-18

Orders for 9-11-18

EFFECTS OF
 DECEASED SOLDIERS.

The only persons authorised to collect effects of deceased soldiers are :-

- (a) The Corps Burial Officer
- (b) Divisional and Brigade Burial officers
- (c) M.C.O.'s in charge of burial parties.
- (d) Any officer may collect the effects where it

would not appear advisable to leave them on the deceased until arrival of the burial party. Where this is done the officer is responsible for handing the effects over to the nearest burial officer, and obtaining a receipt.

Effects will be despatched to G.H.Q., 3rd Echelon, under Divisional Arrangements. Careful records will be kept showing name of deceased and list of articles despatched.

Effects will be sent by registered post. Should there be more than the effects of one man, each will be put in a separate packet, and the whole made into one parcel and sent by registered post. A list of the articles will be enclosed in the parcel, showing the effects of each soldier.

All ranks are warned that to collect or be in possession of the effects of deceased soldiers without the requisite authority, are offences liable to severe punishment.

CROSSES ERRECTED
 OVER GRAVES

On no account will crosses erected over graves by D.G.R. & M. be removed. When a Unit erects a cross, the D.G.R. & M.'s cross should be placed as a feet cross, being driven deep into the ground.

APPOINTMENT

Lieut. S.J. Sawyer will take up his duties as detailed in Company orders dated 6-11-18 as from today.
 Lieut. Justice R.M. will report to O.C. No. 4 Section for duty.
 Transfers of batmen will be arranged mutually and Headquarters informed.

Captain, A.E.

COMPANY ORDERS

By

Major W.S. Anderson, M.C.
Commanding 1st Australian Tunnelling Company

Headquarters
10-11-18

Orders for 10-11-18PARADE.

There will be C.O.'s parade for No. 4 Section at 15.00 10th Inst. Special attention to be paid to dress.
Dress - Drill order.
Nunerals and Regimental colour patches will be issued to Section Q.M.S. and O.C. section will see that all ranks are correctly dressed in this respect.

POSTING.

Lieut P. Jones having resumed regimental duty from General List is posted for duty to No. 3 Section.

REJOINED.

Lieut. W.S. Jones, M.C. rejoined Unit from A.S. Training School House on 9-11-18.

STATIONERY.

A supply of envelopes and stationery has been received from Australia Y.M.C.A. and will be distributed pro rata to Sections and Headquarters.
Headquarters personnel may obtain their quota from the Guard Tent.

REPATRIATION

Repatriation circulars will be distributed to sections today, and every effort will be made to make these as widely known as possible.

TRANSFERS

No. 5431 Sapper W. Walker is transferred from No. 3 Section to No. 1 Section.
No. 245 Sapper A. Fringle transferred from No. 2 Section to No. 4 Section
No. 8230 Sapper Walcott is transferred from No. 4 Section to No. 2.

S. J. Sawyer
Lieut. Col.

NOTICE

CHURCH SERVICE will be held in Marquee at 14.30 Sunday 10th Inst.

254

COMPANY ORDERS

By

Major W.S. Anderson, M.C.
Commanding 1st Australian Tunnelling Company

Orders for 12-11-18

Headquarters
11-11-18

1. VENereal DISEASE. The troops are warned that the prevalence of venereal disease among the German troops who have recently been occupying the towns and villages now falling to us has been very great.
2. BLANKETS ETC. Blankets, underpants, and socks will be issued to sections pro rata by H.Q.M.S. Section C.Q.M.S.'s will arrange collection.
3. MARCHED OUT. Lieut. W.S. Jones, M.C. marched out to Administrative Headquarters on 12-11-18.
4. REPATRIATION. The D.A.G. requests that the entry of "employment guaranteed" or "employment NOT guaranteed" in paybooks of all ranks of the A.I.F. be expedited. Section Commanders will be responsible that this entry is made in the paybooks of all under their command.

S. J. Sawyer
Lieut. A.I.F.

354

SPECIAL ORDER

By Major
Commanding 1st Australian Tunnelling Company

Headquarters
in the Field
11-11-18

DEVOTION TO
DUTY

When publishing this list the G.O. realizes that all ranks of No. 4 section and the Detachment from No. 1 section did remarkably good work on the night 3/4th November 1918, but the following names are mentioned as men showing great gallantry and devotion to duty during the throwing of a heavy beam bridge across the canal on 12/11/18 :-

- 144 s/capt. Hutchinson H.H.
- 108 s/capt. Field F.H.
- 160 " King W.H.
- 2421 s/capt. Kearns J.
- 2552 " Armstrong F.
- 2472 s/capt. McIntosh F.
- 6197 s/capt. Anquet F.
- 2368 " Wilkinson A.
- 3000 s/capt. Allan J.
- 114 " Fulton G.
- 3168 " Bore J.P.
- 2548 " Hindmarsh A.V.
- 174 " King G.
- 2264 " Hobbs J.L.
- 2716 " Mullins J.
- 2180 " Milligan G.
- 7726 " Moore W.J.
- 236 " Peterson H.H.
- 233 " Palmer G.
- 2308 " Quadrio G.
- 1630 " Sheridan F.J.
- 264 " Savage J.
- 262 " Seblac H.
- 277 " Smith J.
- 206 " Taylor A.H.
- 2328 " Thomas F.J.
- 7124 " Temple J.L.
- 215 " Wilson W.
- 223 " Wilson H.

F.S. Anderson

Major, A.C.

354

COMPANY ORDERS

By
Major W.B. AMERSON, M.C.
Commanding 1st Australian Tunnelling Company

Headquarters
12-11-18

orders for 12-11-18

GERMAN SIGNBOARDS.

with the exception of the actual names of towns and villages all German signs will be removed. Area Commandants from Majors, and all formations and Units are required to assist in having this done.

RECOVERY OF
WRECKED AIRCRAFT.

Reports are still being received that machine guns and instruments are being removed by unauthorized persons from captured hostile aeroplanes. The Corps Commander desires that the attention of all ranks is drawn to previous orders on this subject, and that immediate steps should be taken to stop this practice.

HONOURS &
AWARDS.

The Corps Commander Australian Corps has awarded the Military Medal to the undermentioned M.C.O.'s and men for bravery in action on 29-9-18. :-

- | | | |
|-------------|----------|------|
| 245 Sapper | Wriggle | |
| 3892 Supt. | McIntosh | M. |
| 6192 Corpl. | Manlett | M.J. |

In communicating the congratulations of the Corps Commander to the recipients, the Commanding Officer would like to add his own.

S.J. Saurys
Lieut. M.C.

354

COMPANY ORDER

by

Major W. ...
Commanding 1st Australian Ammunition Company

Headquarters
10-11-18

orders for 14-11-18

1. PERSONNEL

To be staff sergeants :-

- 60 Sgt. Bradshaw T. 25-9-18
- 800 " Stevenson J.S. "
- 800 " Bell J.S. "
- 100 " Hutchinson H.B. "

To be company quartermaster sergeants :-

- 173 Sgt. Shores J. 25-9-18
- 0 " Hampson J.S. "
- 804 " Eley J.S. "
- 800 " "

S. J. Sawyer
Lieut. Col.

COMPANY ORDERS

By

Major R.S. Anderson, M.C.
Commanding 1st. Australian Tunnelling Company A.E.

Headquarters
14-11-18

Orders for 15-11-18

PROMOTIONS

Subject to approval from base the following promotions are promulgated.

266	2/Corp.	Spanderson	G.E.	to be sergeant	26-9-18
2772	Corp.	Thomas	L.	"	"
373	"	Broadhead	L.	"	"
242	"	Pierson	A.H.	"	"
2421	"	Kearns	J.	"	"
292	2/Corp.	Sarovsov	S.	to be Corp.	"
147	Sapper	Jones	G.	"	"
3654	2/Corp.	Mozit	T.	"	"
3473a	"	McIntosh	W.	"	"
5442	1/Corp.	Wyman	R.L.	to be 2/Corp.	"
5625	T/2/Corp.	Girard	J.B.	"	25-6-18
296	1/Corp.	Tarsey	J.A.	"	26-9-18
403	Sapper	Hood	R.	"	"
3599	1/Corp.	Fletcher	R.E.	"	"
2368	"	Wilkinson	A.F.	"	"
3644	Sapper	Mobbs.	J.E.	"	4-11-18

APPOINTMENTS

The following appointments are promulgated subject to approval by Base :-

To be L/Corporals :-

166	Sapper	Liade	A.W.
262	"	Sabine	R.M.
323	"	Wilson	H.
114	"	Walton	T.V.
3409	"	Lewis	N.D.

PROMOTION
(TEMPORARY)

No. 403 2/Corp. Hood R. to be T/2 C.Q.M.S. 29-10-18

DETACHMENTS &
TRANSFERS

No. 242 Sergt. A.E. Piersea is transferred to No. 3 Section and detached for duty with Company Headquarters.
No. 147 Corp. Jones G. is transferred from No. 3 Section to Headquarters and detached for duty to No. 3 Section.

KIT INSPECTION

Sections will hold kit inspections without delay.
Kit and equipment will be reduced to a minimum so as to enable Unit to operate as Infantry Unit, if necessary.

Captain A.E.

354

APPENDIX N°1.

13

COMPANY ORDERS.

by,

Major E.S. ANDERSON, M.C.
Commanding Officer
1st Australian Tunnelling Coy. A.S.

In the Field.
15/11/18.

Orders for 16/11/18.

PARADE.

There will be a Company Parade in the Field joining No. 4
Section Camp on the south boundary at 09.00.
Section Commanders will arrange for their Staff-sergeants
to hand over their parades to the Warrant Officer at that hour.
All Officers will report to Second in Command.

DRESS.

Full marching order.

Wm. G. Anderson

Captain A.S.

APPENDIX N°1.

13A.

APPENDIX TO COMPANY ORDERS FOR 16th INST.

by,

Major E.S. ANDERSON M.C.
Commanding Officer
1st Australian Tunnelling Coy.

APPOINTMENT

Lieut. W. Manton is appointed ^{acting} officer Commanding No. 1 Section
as from 16th inst.

Wm. G. Anderson

Captain A.S.

APPENDIX N°115

COMPANY ORDERS.

by.

Major E. S. Anderson, M.C.
 Commanding Officer
 1st Australian Tunnelling Coy. A.E.

In the Field.
 21/11/18.

 Orders for 21/11/18.

CENSORSHIP. The regulations concerning censorship have now been relaxed, and
 all men are allowed to describe where they are and the nature
 of their surroundings.

CAMERAS. The restrictions on the use of cameras are now cancelled.

J. Sawyer
 Lieut. A.E.

APPENDIX N°1

COMPANY ORDERS

By

Major E.S. Anderson, M.C.
Commanding 1st Australian Tunnelling CompanyHeadquarters
21-11-18

Orders for 22-11-18

1. PAY Pay will be distributed to Headquarters and sections Nos. 1, 2, & 3 on 22nd inst. Section Commanders will arrange to collect paybook and forward same to Headquarters by 08.00. Men/ not desiring to draw pay need not hand in their books.
2. ISSUE
ORDNANCE
(clothing) The issue of winter clothing will be continued tomorrow 22nd inst. for Headquarters and Nos 1, 2, and 3 sections. Same will be drawn from E.Q.M.S.
3. FIRE All ranks are reminded of the necessity for screening securely naked lights and fires in billets, especially those containing straw and other inflammable material.
4. SANITATION. O's 3 sections are reminded that strict cleanliness and sanitation must be observed in all billets occupied by their men. All latrines must be disinfected daily.
5. MAIL. All mail must be handed in to Headquarters by 12.00 hours daily.

Lieut. A.E.

354

COMPANY ORDERS.

by.

Major W.S. Anderson, M.C.
Commanding Officer
1st Australian Tunnelling Company A.S.

In the Field
24/11/18.

Orders for 25/11/18.

HONORS & REWARDS. His Majesty the King has been graciously pleased to approve of the award of a BAR to THE MILITARY CROSS, for gallantry and devotion to duty, on 29th September 1918, to Capt. G.H. BUCKWARD M.C.

ROUTE MARCH (during rests). During periods of rest Section Commanders will arrange that their sections route march for 1 hour daily.

REPAIR OF BOOTS. Every advantage is to be taken during rest to have boots repaired. No. 3 section will ~~xxxxxx~~ arrange that boots requiring repair are handed to Company Bootmaker by 08.00 each inst.

BOLSHEVIST LITERATURE. Information has been received that Russian Bolshevists revolutionary literature has been sent to Germany and Holland which is to be introduced into the Allied countries. It is possible that this may come into the hands of the Allied soldiers and returned prisoners of war. Should any such literature be discovered it should be confiscated. Any officer or man found in possession of it should be called upon how it came into his possession. Any officer or soldier found to be distributing this literature should be arrested.

LIGHTS & FIRES. Section Commanders will satisfy themselves that all necessary precautions are taken with reference to lights and fires in billets.

FIRE PICKET. Fire picket consisting of 8 Other Ranks i.e. 2 from each section and 2 from Headquarters, will report at 16.00 daily to Regimental Orderly Sergeant, who will be responsible for mounting of same.

J. Sawyer
Lieut. A.S.

APPENDIX N°118COMPANY ORDER.
by,Major H.S. Anderson M.C.,
Commanding Officer
1st Australian Tunnelling CompanyIn the Field
25/11/18.

orders for 26/11/18.

TRIP TO
CHARLEROI.

1 Officer and 20 Other Ranks from each Section and 15 Other Ranks from Headquarters will proceed by lorries, leaving Headquarters at 09.30, tomorrow 26th inst.

The party selected will be inspected at Company Headquarters by the C.O. before departure.

Dress will be walking out order, belts to be worn. (Sergeants, belts and sidearms).

Lorries will leave CHARLEROI at 15.00 on the return journey.

Rations for mid-day meal will be carried.

Lorries will park at the railway station CHARLEROI, which will be the assembly point for the return journey.

Senior officer accompanying party will be responsible for discipline.

ROUTE MARCH.

Section Commanders will see that the balance of their Sections remaining at Billets tomorrow 26th inst. are taken for a route march between 10.00 and 11.00 o'clock.

ENEMY MONEY.

All enemy coinage and notes, not being legal tender in the Allied Countries, troops are advised not to accept same.

H. S. Anderson
Lieut. A.S.

354

APPENDIX

APPENDIX No. 1.

19.

C O M P A N Y O R D E R S .
by,

Major E. B. Anderson, M.C.
Commanding Officer
1st Australian Tunnelling Company A.E.

In the Field.
25/11/18.
6

Orders for 24⁷/11/18.

TRIP TO

Owing to the fact that the following men :-

CHARLEROI .

2660	2/Corpl.	McMullen J.	No. 3 Section
6675	Sapper	Durkin H.	do
6877	"	Payne L. J.	do
286	"	Stanley J.	No. 2 Section
1322	"	Chappelow W.	do

failed to meet the lorries
at the appointed hour for the return journey on the 25th inst.
and the following men failed to report on the 26th inst:-

366	Sapper	Flynn P.	attd. No. 3 Section
5210	"	Wilkin C.	do
3577	"	Common T.	do
7897	"	Houlahan E.	No. 2 Section.

all future excursions to this town are cancelled.

E. J. Sawyer
Lieut. A.E.

COMPANY by, ORDERS

354
Major R.S. Anderson, M.C.
Commanding Officer
1st Australian Tunnelling Company.

In the Field
29/11/18.

Orders for 29/11/18.PARADE.

Sections will hold parades at 09.00. Dress, drill order with hats.
Company orders and special orders will be read on this Parade.

MOVEMENT.

All ranks, except those on duty, will remain in the village of MARBAIX tomorrow in view of sections moving to new areas for work.

BILLETS.

All troops will be in billets at 21.00, Orderly Sergeants will render Tattee Reports to R.S.M. at 21.30 daily.

OUT OF BOUNDS.

The village of HAM (Army Headquarters) is out of bounds to all ranks except on duty.
The town of CHARLEROI is out of bounds to all ranks except on C.O.'s. Pass.

ORDERLY ROOM

C.O.'s Orderly Room will be held at 10.00.

CONGRATULATORY.

The following congratulatory letter has been received, and is published for the information of all ranks:-

Lieut

" Lieut.- Col. W. GARFORTH, DSO, M.C.
Acting C.M.S., 46th Division.

46th Division G.117/115. 9th November 1918.

The Divisional Commander wishes to congratulate you and the Field Companies under your command on the excellent work carried out during the last few days.

Please inform all ranks of the Royal Engineers that their efforts have been highly appreciated.

Will you also please convey to Major Wilson, Cndg. 256th Tunnelling Company, R.E., and to the C.O., 1st Australian Tunnelling Company, the thanks of the Divisional Commander for the valuable services rendered by the sections of their respective Companies.

(Sd). F. HAY, Mjr. for Lieut. Col.
General Staff, 46th Division.

(S)

C.O., 1st Australian Tunnelling Co., R.E.

(1) I have much pleasure in forwarding the enclosed letter, received from the Divisional Commander on the recent work carried out by your Company.

(2) The C.O.C., is particularly pleased with the work done by Capt. HINDER and his Officers, M.C.O.'s, and you, all of whom have displayed the keenest interest.

(Sd) W. GARFORTH, M/Lieut. Col.
A/S.A.S., 46th Division

W. Garforth
AE

APPENDIX N°2

APPENDIX 1

COPY.

No. 4 Section
1st. Aust. Tunnelling Coy.

C. R. E.,
1st. Division, B.E.F.

I have to advise that the Tank Bridge which was to be erected by this Section was successfully erected by 10.30 4/11/18.

The bridge was constructed to plan as per your amended plan of 4th inst. except that 13 girders, 20' 10" X 5" R.S.J. were used instead of 14 as shown in plan.

The level of bridge was brought to that of lock coping by removing coping of same. Shore transoms were laid on 2' solid brickwork forming sides of canal.

A departure was made by substituting 9" X 3" timber in lieu of 10" X 10" for ribbons as the latter I thought would be of greater value to enable the Field Company R.E. 46th Division to construct a Tank Bridge over the stream before the lock proper was reached, as I knew them to be short of adequate material.

The general outline of action was followed as per your verbal instructions and I wish to be allowed to bring to your notice, the excellent conduct and assistance of the C.O. of the 409th Company R.E. I feel sure that this Officer's conduct, by his personal attention to his own company's work and the work of this Section under most adverse and dangerous conditions, was such that he inspired confidence in all Officers and Other Ranks of the 1st Australian Tunnelling Coy. who were associated with him in the operations.

I have to advise that 80 T.N.T. high explosive charges were removed by this Section from the foundations of the building on the West side of the bank.

1st AUSTRALIAN TUNNELLING COMPANY.	
No.	S/409
Date	4-11-18

(Sd) O.H. WOODWARD, Capt. A.E.
Officer in Charge
No. 4 Section,
1st Aust. Tunnelling Coy.

C.R.E. 1Xth Corps Troops

For your information please,

4-11-18

W. Woodward Capt. A.E.
For C.O. 1st Australian Tunnelling Company,

*O.C. 1st Aust. Tunnelling Coy -
The Tank bridge requires a notice board and direction boards
from main roads at both ends of the canal - The bridge over the
P.T.O*

APPENDIX

APPENDIX No. 2

Stream ~~to~~ West of dock does not appear very sound
+ the approaches to it are very bad - There ^{points} should
be seen to by your party detailed to work on
the "Lane"

5
12

W. T. Walsh
C.R.B. 9/11/18

IX CORPS
380/46

The bridge was constructed as per your memorandum of 4th inst. except that 10" x 8" R.S.J. were used instead of 14 as shown in the plan. The level of bridge was brought to that of lock coping by removing coping of same. A structure was made by substituting 2" x 2" timber in lieu of 10" x 10" for timbers on the latter I thought would be of greater value to enable the Field Company R.E. to construct a Tank Bridge over the stream before the lock proper was reached, as I knew them to be short of adequate material.

2/11/18
4/1/18

(Sd) G.H. WOODWARD, Capt. R.E.
Officer in Charge
No. 4 Section
1st Australian Tunneling Coy.

O.R.B. 1Xth Corps Troops

For your information please

APPENDIX No 2

1ST. AUSTRALIAN TUNNELLING COMPANY A.E.

Headquarters
7-11-18

354

To/

From C.O. 1st. Australian Tunnelling Company A.E.

Report for week ending 6-11-18

ROADS

Read from V.22.b.4.2. to V.22.d.8.4. completed.
Box culvert at junction V.16.d.8.4. completed.
Read at S.1.d.3.4. (Canal Bridge) approaches both sides made good and shell-holes filled.
Read reconnoitered from G.35. Central to Landrecies, Landrécies to Ors, Catillon to Fme Madame.

BRIDGES.

All Bridges over La Selle River patrolled. Hand rail on St. Martin No. 1. renewed All Bridges over La Selle river double decked.
Tank Bridge at S.1.d.3.4. Sh. 57A. over Canal De La Sambre erected successfully.

MINES

Inspected Billets in Busigny no trace of Mines found. Examined Billets U.28.d.8.0.1.5. (xreads Prement-Behain). A gallery 25 feet long under Read inspected and 18 feet of tamping and quantity of explosive removed. Cellar on opposite side of read inspected, gallery 12 feet long found but not charged. Cinema at Busigny examined no trace of Mines found. Branceourt Church examined for Mines no traces found in foundation but quantity of Perdite found from room near the top. South side of bridge at V.21.d.8.6. Cleared and searched without result. Foundations of house at west side of Canal at S.1.d.3.4. examined and quantity of explosives removed. Shaft at D.3.c. Sh. 62B. opened to 3 feet below demolished portion (total 9 feet) and no sign of charge found. From 2 fixed bridges over canal between S.8.d.8.8. and S.7.b.6.9. and from 1 floating bridge 9 charges removed. From S.2.d.6.2. charge removed from culvert. From M.26.a.6.2. 8 charges removed from read and bridge. Several reads and houses examined without result. From S.7.b.6.9. to S.8.d.8.1. charges removed. From read junction W.19.b.3.7. 5 unexploded mines removed. From N.19.b.4.8. 4 unexploded mines removed. G.35.c.9.4. shaft on east of read electric leads cut charge net removed. H.31.c.3.1. 2 lengths of instantaneous fuse cut, charge net removed. M.4.b.4.9. no trace of Mines found. N.1.a.9.5. 6 charges under arches removed of bridge removed. G.29.a.1.5. 9-6 1/2 inch shells under arch of bridge found, 2 fused, all detonated, fuses and detonators only removed. G.28.d.6.0.0.5. shaft on N.W. side of read fuses cut charge net removed. G.28.d.5.0. under culvert fuses cut charge net removed. Tank Mine found at M.1.d.25.80. 6 small charges (contact Mines) found at M.1.d.0.8.

EXPLOSIVES

1,300 Kilogs. of Perdite removed from cellar at Busigny Station. From Gallery under cross reads Prement-Behain the following were removed, - 23 cases (25 pkts. each) of perdite 1 kilo packets, 8 cases (8 pkts. each) of perdite 3 kilo packets, 7 detonators, 1 electric detonator and 1 ordinary detonator. From Branceourt Church 200 lbs. of perdite removed also several detonators. 80 T.N.T. H.E. charges removed from foundation of building on West Side of Canal at S.1.d.3.4. 9 charges removed from bridges over canal between S.8.d.8.8. and S.7.b.6.9. 1 charge removed from culvert at S.2.d.6.2. 8 charges removed from read and bridge at M.26.a.6.2. Charges removed from read at S.7.b.6.9. 5 Mines removed from read junction W.19.b.3.7. 4 Mines removed from reads N.19.b.4.8. The above Mines consisted of shells about 10 inch and 3 feet long. The charges removed consisted of a box of explosives with detonators fused and friction lighter. Charge at G.35.c.9.4. consists of 6 cases of Perdite. At N.1.a.9.5. about 550 lbs. of perdite removed, both commercial and electric detonators in charge.

G.29.a.1.5.

(2-

EXPLOSIVES G.29.1.5. 9-6 $\frac{1}{2}$ inch shells 2 fused all detonated. G.28.a.5.0. boxes of Perditite under culvert fuses cut.

MISCELLANEOUS

Construction of Rifle Range completed.
 No. of Netice beards made and erected on various bridges and roads constructed and maintained by this Company.
 Advanced H.Q. NO. 2. Section moved to W.6.a.7.2. on 3-11-18.
 " " " 2. " " " Q.33.b.2.6. " and returned to Company H.Q. on 6-11-18.
 No. 1. Section moved to X.3.b.1.3. on 6-11-18.

CASUALTIES

<u>K.I.A.</u>	<u>K.I.A.</u>	<u>W.I.A.</u>
3	O.R.	8 O.R.

STRENGTH.

Officers	22	Other Ranks	540.
----------	----	-------------	------

Wynne Bird

Captain, A.E.

Per C.O. 1st Australian Tunn. Company, A.E.

APPENDIX N°2

3

SUPPLEMENTARY TO WEEKLY REPORT DATED 7-11-18

EXPLOSIVES

FOUND

	No	Location	Type	Approx weight
<u>LAND MINES</u>	5	N.19.b.3.7	10" shells	
	4	N.19.b.4.8	10" "	
	1	G.29.a.1.5	9-6 1/2" shells	
DEMOLITION CHARGES (Including road & rly charges)	1	G.28.d.5.0	Bboxes of perdite	
	1	Prement-Behain x Roads	perdite	767 kilos
	1	S.1.d.3.4.	80 T.N.T.	
	9	From bridges between S.8.d.8.8 & S.7.d.6.9		
	1	S.2.d.6.2.		
	8	M.26.a.5.2.		
	-	S.7.b.6.9.		
	1	G.35.c.9.4	6 cases perdite	
1	N.1.a.9.5	perdite	550 lbs.	
<u>EXPLOSIVES REMOVED</u>		Cellar at Busigny Station	Perdite	1300 kilos
		Branceourt Church	Perdite	200 lbs.

A. E. ...

Captain. A.E.

For G.O. 1st Australian Tunn. Company, A.E.

8-11-18.

354

1ST AUSTRALIAN TUNNELLING COMPANYHeadquarters
8-11-18

To

From C.O. 1st Australian Tunnelling Company

The following areas have been searched for mines etc. with results as shown :-

- S.1.d.3.4. Foundation of house W side of canal examined and quantity of explosives found. Charges removed.
- ~~S.8.d.8.8.~~
S.7.b.6.9 to S.8.d.8.8. terrain two fixed bridges and one floating bridge - 9 charges removed.
- S.2.d.6.2. Charge removed from culvert.
- M.26.a.6.2. 8 charges removed from road and bridge.
- M.28.b.3.2. Roads and houses searched. No mines found.
- M.20.a.9.7. Through St Martin to Le Menage to M.33.b.2.9. Examined but no mines traps etc found.
- Le Menage to M.32.c.5.7 to M.32.d.6.6. through Chapeau Rouge. Examined. No traces of mines traps etc found.
- M.1.d.6.3. to M.3.c.5.0. Examined, nothing found.
- S.7.b.6.9 to S.8.d.8.1. Charges removed.
- W.19.b.3.7. 5 unexploded mines removed from Road Junction.
- H.19.b.4.8 4 unexploded mines removed.
- G.35.c.9.4. Shaft on east of road examined. Electrical/ leads cut charge net removed.
- H.31.c.3.1. 2 lengths of instantaneous fuse cut. Charge net removed.
- M.4.b.4.9. No trace of mines found.
- S.1.a.9.5. 6 charges under arches of bridge removed.
- G.29.a.1.5. 9 6 $\frac{1}{2}$ " inch shells under arch of bridge found. Two fused, all detonated. Fuses and detonators only removed.
- G.28.d.60.05 Shaft on N.W. Side of road. Fuses cut charge net removed.
- G.28.d.5.e. Under culvert fuse cut, charge net removed.
- M.1.d.2.5. Tank mine found.
- M.1.d.e.3 6 small charges (Contact mines) found.

Captain, A.E.
For C. O. 1st Australian Tunn. Company, A.E.

354

APPENDIX N°2

10

COPY

No. 2 Section
11-11-18

C.C.
1st Australian Tunnelling Company
Daily work report.

BOHAIN - BEAUMONT Light Railway.

Inspection completed between Berets and Blincourt. Four mines had already been removed and notices to that effect erected. Also in U.4.b. were four small shafts but no explosives or traces of mines found. Mines removed were at U.5.c.5.9., U.5.a.1.1. (2) and U.10.a.1.8 (Approx)

BOHAIN - BOUIGNY :-

"A" shaft	36' deep	No traces of mines found
"B" "	14' "	" "
"C" "	18' "	" "

(In "B" at about 12' two pieces of time fuse (Haburat) were found. These were probably in the surface demolition charge) One undamaged shaft was explored; two small caddies have been driven from the shaft bottom for about 4' - size 2'6" x 4'6".

FRESNOY :-

Started to search for mines at level crossing but found no traces. No. 4 section have now resumed the supervision of the search at Fresnoy.

(Sigs) D YETTS, Capt. AM.
C.C. No. 2 Section.

COPY :-

C.C. 1st Australian Tunnelling Company

As instructed I examined FRESNOY Station Yard to a further extent for mines etc. I found none. I also examined Railway track from Fresnoy to Bohain and found no trace of existing mines.

11-11-18. (Sigs) R.M. Justice, Lieut. AM.

COPY.

C.C. 1st Australian Tunnelling Company

In accordance with your orders work was stopped on H.T. Road. Removal of tank bridge will be completed today and material will be placed at church REJET de BEAULIEU (sheet 57b S.E. K.11.b.1.4.. Your orders re barricading H.T. Road and patrolling bridges are noted.

11-11-18. (H.D.HILL Lieut. AM.
C.C. No. 1 Section.

APPENDIX No 2

4

354

1ST AUSTRALIAN TUNNELLING COMPANY

Headquarters
14-11-18

TO

FROM C.O. 1st Australian Tunnelling Company, A.S.

REPORT FOR WEEK ENDING 13-11-18.

1. ROADS.

S.L.D.3.4 Road Repaired each side of Tank Bridge over Canal de la SAMBRE.

2. BRIDGES.

Handrail over St. Mattia Bridge broken - now repaired.
All bridges over La Belle River patrolled and in good order.
Tank Bridge over Canal de la SAMBRE at S.L.D.3.4 removed and stored.

3. MINES.

HONNECHY - BRANCOURT metre gauge Railway searched for mines from HONNECHY to MARTEZ and from BRANCOURT to SERAIN - Two small shafts at P.33 opened up. No mines found.
FRESNOY Station Yard examined - No mines found.
R.T.O's Billet BUSIGNY examined - No mines found.
Cellars and houses adjacent to Station Yard and Level Crossing at FRESNOY examined - No traces of mines found.
BOHAIN - BUSIGNY Railway searched. "A", "B" & "C" shafts emptied - No traces of mines found.
Line from FRESNOY to BOHAIN examined - No mines found.
Chateau at FROYART examined - No mines found.
46th Divisional Area East of Le CHEVAL BLANC examined for mines traps etc and charges removed from Railway Bridge at R.19.c.2.; also at Q.13.b.5.9, Q.24.a.5.6, K.29.b.4.5., K.30.a.2.9., Q.10.d., K.29.b.3.6., K.30.a.3.8. and Q.9.c.9.1. All sheet 57A

4. EXPLOSIVES FOUND.

Demolition charges :-		
Location	Type	Approx weight.
R.19.c.2.3		80 lbs.
Q.17.b.6.9		400 lbs
Q.24.a.5.6	2 D.A. charges	200 lbs.
K.29.b.4.5		700 lbs
K.30.a.2.9.	1 Time fuse	
	2 elec "	
	1 Bottle acid with lead	20 lbs.
K.29.b.3.6		300 lbs.
Q.10.d.		40 lbs.
K.30.a.3.8.		300 lbs.
Q.9.c.9.1.		120 lbs.

5 MISCELLANEOUS

1 officer and 12 other ranks attached for work to Australian Corps Headquarters Le GATEAU 8-11-18 to date.
No. 3 section moved forward to H.23.b.6.4 sheet 57A 7-11-18.
" " " Q.10.b.9.1. " 10-11-18
" " " R.14.a.3.4 " 12-11-18

6 CASUALTIES

N I L.

7 STRENGTH.

Officers 22 Other ranks 522.

W. J. W. B. B.
Captain, A.S.
For C.O. 1st Australian Tunnelling Company.

1ST AUSTRALIAN TUNNELLING COMPANY

Headquarters
21-11-18

To

From C.O. 1st Australian Tunnelling Company

WEEKLY REPORT FOR WEEK ENDING 21-11-18

1. BRIDGES . NIL

2. MINES. Suspected Delay Action Mines on CHAULMES - PERONNE Railway :-
 - (a) 81 Metres North of crossing CHAULMES - MARCHLEPOT Road.
 - (b) 118.3 metres South of Crossing GEMERMONT - MARCHLEPOT Road.
Both inspected. No. 1 Exploded on 9th inst. Eight holes in vicinity of No. 2 opened up. No trace of Mines found.
 - (c) Sheet Namur Location 4/D.0495. Consisted of one shaft and one drive under road.
From Shaft removed 750 lbs perdite in Tins
 " Drive " 550 " " "
Electric leads and safety fuse firing apparatus.
Notice boards indicating removal erected.
 - (d) Under Railway Bridge C.4. 9382. One small charge of 12 lbs perdite removed.
 - (e) D.3. 3822. Mine consisting of 37 tins of H.E. about 75 lbs weight each. Electric and safety fuse leads. Shaft on each side of Bridge to demolish abutments and charge under arch.
 - (f) D.2.8263. Examined mine shafts at Road junction. Shafts bottomed at 9', but no explosives found. Enemy had apparently filled in shafts without the charges as 40 tins of H.E. were found about 200 yards distant.
 - (g) D.4.99.59. Two shafts on either side of bridge.
 - (h) D.4.97.54. Three shafts. One each on abutments of bridge and one on wall to prevent detour being made.
(g) (h) opened up and worked at until dark 18th inst
Shafts were 3' x 3' so progress wa slow. On C.R.E's instructions tops of shafts were covered securely, and clearly marked same for following R.E's to extract.
 - (1) D.4.97.52 - Two Shafts. Mines located & indicated.
 - (j) D.4.9449 - " " " " "
 - (k) D.4.9762 - " " " " "
 - (l) E.4.0351 - " " " " "

NOTE (a) & (b) Investigated 13/14th November 1918
 (c) to (l) " 18th " "

3. EXPLOSIVES. Explosives found as indicated in Para (2)

4. MARCH TO THE RHINE
On the 15th inst this Company Received Orders to accompany 1Xth Corps on the march to the Rhine. No 1 Section under Lieut. Manton attached to 199 Inf Bde, 66th Division. No. 4 Section under Captain Woodward attached to 1st Infantry Bde 1st Div. to lead the Corps in case of mines or traps being discovered. Headquarters, Nos 2 & 3 Sections marched with "B" Col. On the 20th inst No. 1 Section had reached CERFNTAINE.

354

APPENDIX N°2

6

354

Cerfontaine

(2)

- 4 Contd. Headquarters and Nos 2 & 3 Sections located at CERFONTAINE. No 4 Section located at HAMUR sheet 8 4.C.00.85. on 20-11-18.
5. MISCELLANEOUS. 86 Other Ranks remained at BUDIGNY, being unable to participate in the march to The Rhine, in accordance with LXth Corps Administrative Instructions.
6. CASUALTIES NIL.
7. STRENGTH. Strength as per A.F/ B. 213 :-
21 Officers 547 Other Ranks.

W. J. W. Jones

Captain, A.E.

21-11-18.

For G.O. 1st Australian Tunnelling Company, A.E.

APPENDIX N°2

7

354

1ST AUSTRALIAN TUNNELLING COMPANY A.E.

Headquarters
28/11/18.

To.
From C.O., 1st Aust. Tunnelling Coy. A.E.

REPORT FOR WEEK ENDING 27th NOVEMBER 1918.

ROADS.

Road PHILIPPEVILLE - MORVILLE. Road in very good order - cross drains dug between 16 & 20 kils. posts on the sides of the road.

Culvert at L'ECRIVISSE - Drive 5' x 3' x 56' made under road embankment.

MINES.

Location.	Type.	Action.
3.G.13.13.	Rly. crossing & Station	No trace of mines found.
3.G.42.11.	Level crossing	do
3.G.86.22.	do	do
3.G.91.23.	Rly. station	do
3.H.20.30.	do	do
3.G.81.32.	Road Bridge	do
3.H.48.22.	Level crossing	do
3.H.32.07.	Overhead Bridge.	do
3.H.20.05.	Level crossing	do
4.H.30.99.	Road Bridge	do
4.H.26.90.	do	do
3.H.20.05.	FLORENNES station	do
3.G.75.18.	Rly. bridge.	do
4.G.15.70.	Road Bridge	10 charges (5 each abutment) approx. 30 lbs perdite each charge. Instantaneous fuse. charges removed.

CHAMMONT railway examined, 3 miles S. of CHAMMONT - no trace of mines found.

Railway from CHAULNES - FLORENNES and to ROSEE examined - no trace of mines found.

Line 3 miles N. and S. of CERPONTAINE examined - 60 charges removed and presence reported of an ammunition train in a heavily charged tunnel 4 miles S. of CERPONTAINE.

Roads, Railways and Bridges examined at TEUILLIES (NAMUR sheet 8 S.D.) examined 18 bridge and road mines also railway yard - all charges had been removed.

Examined Railway line and adjacent road in triangular area bounded by FRAIRE - FAIRONT to ROSSIGNOL and back to YVES GOMEZEE, at F.78. 03 railway bridge found to be prepared for charges but not completed.

Examined Railway line from YVES GOMEZEE to ST. AUBIN and Railway Yard at ST. AUBIN. at G.80.94. road bridge, removed 300 lbs. perdite, fuses were not inserted - cases were removed from site. At 4 G.97.99. on road crossing at ST. AUBIN, removed 300 lbs. perdite and destroyed the detonators. Examined roads and culverts from YVES GOMEZEE to DAUSSOIS (and village) thence to SILMERRINUX - PHILIPPEVILLE road.

At 4.P.54.57. and along that road to 4.P.92.45. thence to village of JAMIOLLE and vicinity and on to FRAIRE - PHILIPPEVILLE road at 4.G.18.77. and thence to YVES GOMEZEE - no trace of mines located on this circuit.

Bridge over the MEUSE river at DINANT (3.K.95.15) examined - no trace of mines found.

MOVEMENTS.

Headquarters and Nos. 1, 2 & 3 Sections marched from CERPONTAINE to CHAMMONT, 24/11/18. No. 4 Section marched from YVES GOMEZEE to COHENNE on 23/11/18. No. 4 Section marched from COHENNE to ROSEENNE on 24/11/18.

CASUALTIES

Nil.

STRENGTH.

22 Officers 530 Other Ranks.

Wm. G. ...
Captain A.E.
for C.O., 1st Aust. Tunn. Coy.

APPENDIX 2

APPENDIX N°2

1ST AUSTRALIAN TUNNELLING COMPANY A.E.

8

Headquarters
29/11/18.

To. *C. of Monis 4th Army*
From C.O., 1st Aust. Tunnelling Company A.E.

Hereunder copy of report rendered to this Headquarters
by Officer in charge of job at L'ECRIVISSE:-

I have to report commencing work at 10.30 a.m.
24/11/18, at L'ECRIVISSE, (Sheet 57. A.9.d.2.B).
A gallery was driven through the road embankment
as shewn on sketch ~~below~~ *attached*
This work was completed and the gallery immediate-
ly under the roadway stayed, by 17.00 27/11/18.
Detachment returned to Headquarters 29/11/18.

(Sd) D.W.BONAR, Lieut.
No. 2 Section, 1st A.T.C.

Lieut. A.E.

Adj. & Q.M., 1st Aust. Tunnelling Company A.E.

354

APPENDIX 2

APPENDIX N°2

9

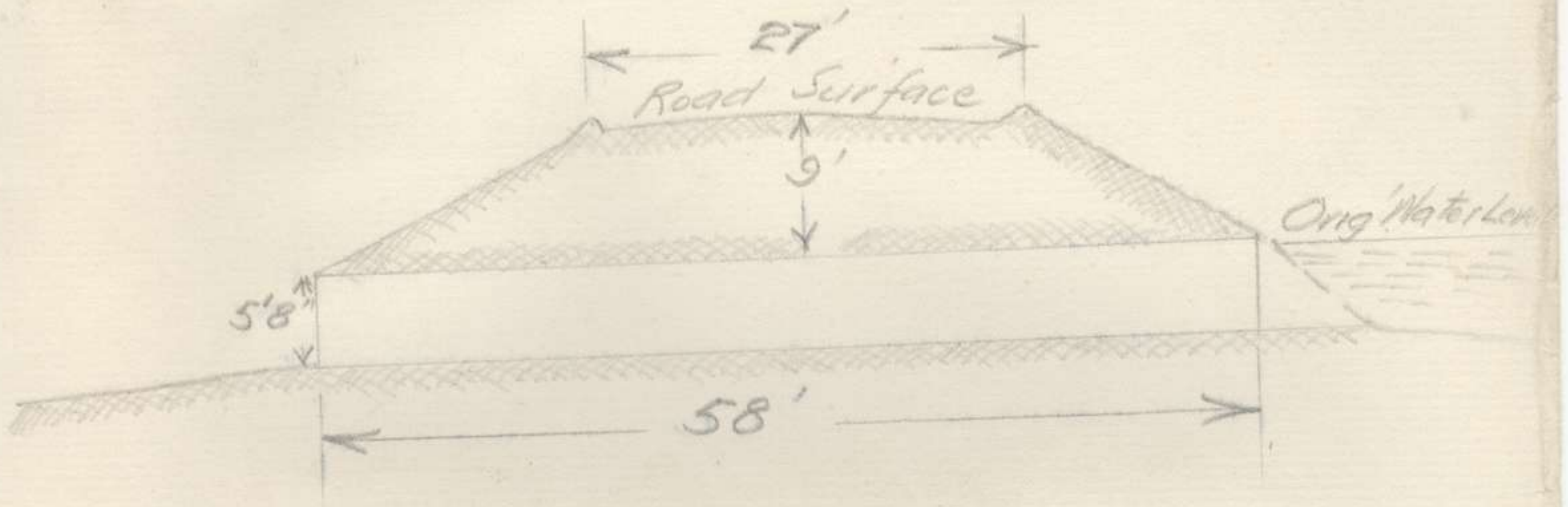

AQUEDUCT

N. Solre-le-Château

Sh. 57 A.9. d.R.B.

Scale: 1" = 12 1/2'

(COPY)

354

No. 1 Section
29/11/18.

Commanding Officer
1st Australian Tunnelling Company A.E.

In accordance with your instructions, I proceeded today with party of 12 Other Ranks to FONTAINE VALMONT and LOBBES. At the latter place I withdrew the charges in the Railway Bridge over the SAMBRE at, NAMUR Sheet 8, 1/100,000, 2.0.02.20.

There was a shaft in each abutment each containing over 3,000 kilos of explosive, also 32 demolition charges on the members of the bridge, which were also removed.

In each foot of the abutments were holes containing no explosives. The wiring was done but charges not detonated.

At the former place, from the Railway bridge at NAMUR Sheet 8, 3.0. 62.88. I removed 56 demolition charges from the members of the bridge, also the charges from the foot of the abutments. There were 4 charges, each containing 5 tins (about 25 kilos each) and some shells. 4 Shells had nose caps and these were left on the bank for inspection, the remainder had the nose caps removed. There is a shaft in each abutment, which I had no time to touch.

There are said to be short galleries at the bottom of these (civilian information). One shaft is partly filled with ballast, the other appears to have collapsed from the bottom.

I suggest that the party dealing with these shafts should take 4 buckets with 20 ft. each of rope, a saw and mining timber as well as picks and shovels. A squad of men would be sufficient.

At the request of the Bourgmestre (letter attached) an aero bomb was removed from the village.

The party has returned to billets.

(Sd) Henry D.HILL, Lieut. A.E.

NOTE. The demolition charges at the latter bridge were wired and detonators placed ready for insertion.

(SD) H.B.H.

354

ISV AUSTRALIAN TUNNELLING COMPANY A.B.

" Casualties and Sick during November 1918 "

CASUALTIES

November 4th.	3 O.R.'s.	K.I.A.
" "	6 "	W.I.A.
<hr/>		
November 11th.	1 O.R.	Died of Wounds.
----- 66666-----		

S I C K.
(including injured, excluding dental.)

	<u>TO HOSPITAL.</u>	<u>FROM HOSPITAL.</u>
Ist. Week.	6	3
2nd. Week.	2	9
3rd. Week.	6	.
4th. Week.	10	2
Totals for Month.	----- 24. -----	----- 14. -----

SECRET

C.B.E., 32nd. Division Operation Order No. 74.

1st November 1918.

1. An offensive operation will be undertaken shortly on a broad front. The 9th. Corps is to force the passage of the Oise-Sambre Canal connecting on the right with the 1st. French Army, 15th. Corps (French) in the neighbourhood of Bergues & on the left with the 8th Corps S. of Landrecies.
2. On the 9th Corps front the 1st Div. is to attack on the right, & the 32nd Div. on the left. The Div. operating on the left of the 32nd Div. is to be the 25th Div. 8th Corps.
3. The 32nd Div. attack will be carried out by the 14th Inf. Bde. on the right, 96th Inf. Bde. on the left.
4. The 97th Inf. Bde. will be in divisional reserve and will be prepared to continue advance E. from the red line the early morning of 2nd day.
5. The date of the attack and zero hour will be notified latter.
6. (a) Crossings of the canal will be effected by the 14 Inf. Bde. between E. 11. b. 8. 4. & the southern outskirts of Ors. by the 96 Inf. Bde. between L. 36d. 7. 3. and the bend of the canal at G. 26. c. 6. 7. Should marshy ground W of canal on the 14 Inf. Bde. front make passage impracticable; the 14 Bde. will cross at Ors and north of it.
- (b) The opening line of the rigid Artillery barrage which will fall at zero hour will be the eastern bank of canal, where it will stand for 5 minutes, then lift 300 yards & stand for 30 min., thence to the yellow line the barrage will move Eastwards at the rate of 100 yds. in 6 min. On reaching a line 300 yds. East of the yellow line it will stand for 15 min. It will then reopen on a line R. 12. c. 0. 5. - G. 33. d. 6. 8. and move E. at the rate of 100 yds. in 6 min. till reaching a line 300 yds. E. of the dotted blue line where it will stand for 45 min. E. of this line rigid Art. barrages supporting the attack to the blue line will be arranged direct between Inf. Bdes. concerned & their affiliated Art. Group Command.
- (c) During the advance Liaison posts will be established by 14 Inf. Bde. with the 1st Div. on their right on the road about H. 20. a. 3. 7. & on their right boundary where cut by the dotted blue and blue lines with the 96 Inf. Bde. on the inter-bde. boundary where cut by the yellow, dotted blue, blue and red lines. Liaison posts will be formed by the 96 Inf. Bde. with the 25 Div. on their left at G. 22. a. 0. 9. - G. 22. b. 5. 0., at the practice trenches G. 23c. 0. 2.
- (d) To protect the left flank of their advance a minor operation will be undertaken by the 96 Inf. Bde. prior to the day of the main attack to clear the high ground in squares G. 20 & 21, 26, & 27 S. of the Div. Bdy. & as far E. as road running through G. 26b., G. 27. a., G. 21. c. This operation will be supported by a creeping rigid Artillery shrapnel barrage over the ground to be cleared & a standing barrage on the ground E. of the canal in squares G. 26. a. & d., G. 32. a. & b., G. 33. a. & b., G. 27. d., G. 28. c.
- Three tanks are allotted to the 96 Inf. Bde. for this operation.
- (e) In order to establish crossings over the canal on the front of the 96th Infantry Brigade before Zero, artillery concentrations will be fixed nightly on the Eastern bank of the canal between L. 36. c. 8. 2.

(and

and the bend in G.26.c. also as a feint in squares G.33.b. and G.27.d.

On Y/2 night on the termination of those concentrations small parties will be passed to the E. bank of the canal to cover the building of bridges.

(f) To assist in covering the crossings of the canal, 6 Mortars of No. 1. Special Coy R.E. are allotted to each of 14th. and 96th. Inf. Bdes, to fire smoke bombs.

7. Field Companies.

(a) 206th. Field Coy. R.E. (plus 2 platoons 16th. H.L.I.) will construct a foot - bridge at R.5.d.7.7. or repair the existing bridge at this site.

They will also make crossings for Infantry over the lock at ORS S. of the main road.

If approaches are found to be usable by horse transport a crossing for Horse Transport will be made over the lock.

(b) 218th. Field Coy R.E. (plus 1 Coy of 16th. H.L.I.) will construct foot - bridges over the canal between ORS and the bend at G.26. Cent.

When these are completed and as soon as the situation permits of transport being brought down to the canal they will erect a pontoon bridge at L.36.b.7.3. The bridging equipment of 219th. Field Coy R.E. is placed at disposal of 218th. Field Coy R.E.

(c) 219th. Field Coy. R.E. (plus 2 platoons 16th. H.L.I.) will construct a Tank bridge at ORS. The stores for this bridge will be parked in R.1.c. on Y/2 night and remain there until the situation is clear for Lorries to go forward. An Officer will be sent to BOHAIN to supervise loading of stores and a guide provided.

Os. C. Field Coys, will arrange to keep in touch with 14th. and 96th. Bdes.

The foot-bridges over the canal will be commenced at Zero plus 5 minutes. Stores for these bridges must be assembled at the Canal bank or as near to it as possible not later than Y/2 night.

(d) 16th. H.L.I. Pioneers will detach 2 Coys to assist Field Coys R.E. They will also be responsible for roads up to nd. E. of the canal. The roads on which work should be concentrated are :-

- (1) BAZUEL - ORS - LANDRECIES.
- (2) BAZUEL - CATILLON - PRISCHES.

(e) Section 1st. Australian Tunnelling Coy.

This Section will be distributed between 14th. and 96th. Inf. Bde. and will search for and destroy landmines, booby-traps, etc., special attention being paid to the two roads mentioned above.

During operations they will be attached to 206th. Field Coy. R.E.

8. Os. C. Companies will arrange for reports to be sent in as soon as bridges are completed.

O.C. 219th. Field Coy. will report as soon as possible he commences work on his Tank bridge and probable hour at which it will be completed.

9. C.R.E.'s. H.Q. will move probably on Y day to BAZUEL.

10. ACKNOWLEDGE

issued at 2100.

Lieut.-Colonel R.E.
C.R.E. 32nd. Division.

354
46th. Division Operation "E"
R.E. and Pioneer Instructions.

Reference Divisional Engineer Order No 73.

The following programme of work for Sappers and Pioneers will serve as a guide for the preparation which Unit Commanders have to make.

1. AS banks of canal are reported to be 6 to 8ft. above water level they will have to be cut down as low as possible (minus 3 feet), before bridging is started. A party of Pioneers to be detailed for this cutting to be at least 8 feet wide at the bottom.
2. A stream reported 6 to 16 feet wide runs west of and close to bank of canal. This will have to be bridged.
3. Approaches to bridges all have to be cleared, (hedges cut etc.)
4. Tracks from nearest road, West & East of canal to bridges to be clearly marked with notice boards (for day and petrol tin lamps for night). Notice boards are being prepared for this.
5. Bridge capacity to be marked on notice board at each end of bridge.
6. Six extra pontoons complete with equipment stored at W.6.c. will be available if required.
7. A small party of Pioneers will improve shelter for bridge maintenance detachments - on West bank of canal.
8. After the 3 bridges have been completed O.C. 466 Field Co. will make approaches to one of the bridges (whichever is most suitable) fit to take horsed transport.
9. Felling axes (for cutting away felled trees etc.) ladders for negotiating canal banks, tracing tapes, for marking approaches, spare timber, for odd jobs, picks & shovels, spare lashing, canvas for bridge screens, nails and hammers, mauls and pickets, sandbags, should all be taken to site of bridge.
10. Progress, as well as completion, of bridges to be reported to C.R.E.
11. On completion of his bridge O.C. 388 Field Co. will hand it over to O.C. 466 Field Co. for maintenance, & will then improve E. approaches to his bridges.
12. O.C. 1st. Monmouthshire Pioneers will attach 100 Pioneers to 466 Field Co. & 150 to O.C. 468 Field Co. for the above work, & these men will be returned to O.C. 1st. Monmouthshire Regt. (at place arranged by O.C.) as soon as O.C. Field Coys. no longer require them.
13. O.C. 1st. Monmouthshire Pioneers will be prepared when notified by C.R.E. to send remainder of his Battalion forward to repair main roads running E. between the line - CATILLON - M33. central - N. 19. central - & the line S. 15. central. Sh. 57A. 1/40,000.
14. The detachment 1st. Australian Tunnelling Co. (mine searchers) will accompany the Pioneers mentioned in para. 13 above.

Sgd.

Lieut. Col.

C.R.E. 46th. Division.

2/11/18

46th Divisional Engineer Order No 73
 By Lt. Col. W. Garforth D.S.O., M.C.
 Commanding Royal Engineers 46th Div.

Operation "F"

2nd November 1918.

1. The 9th Corps will, at an early date, force the passage of the SAMBRE-OISE Canal, in conjunction with 14th French Corps on the right & 13th British Corps on the left.
2. The 1st Division will attack on Right & 32nd Division on left.
3. The 46th Division will be in reserve & will be prepared to relieve the 1st Div. after its capture of the final objective, and exploit success.
4. Bridges of various capacities which will be constructed by 9th Corps 1st Div. & 32nd Div. are shown on Map "P" attached.
5. In addition to the bridges above, 46th Div. will construct 3 medium Pontoon bridges over the canal between M. 31.d. 4.5. & S. 1 D. 8.8. These bridges will only be fit for Infantry, but it is hoped that on Z plus 1 day, they may be fit for Artillery.
6. At Zero hour the three field Coys. & 1/1 Monmouthshire Pioneers will be located in square W. 6. c. & W. 6. d. & will be prepared to move off at five minutes notice.
7. Engineers & Pioneers will be employed as below, & work start at a time to be notified by C.R.E.
 - (a) 465 field Coy. R.E. In reserve
 - (b) 466 field Coy. R.E. Construction of 2 & maintenance of 3 medium pontoon bridges in Sq. S. 1. b. & S. 1. d.
 - (c) 4th field Co. R.E., construction of 1 medium pontoon bridge in Sq. M. 31. d.
 - (d) 1/1 Monmouthshire Pioneers. Construction of approaches to bridges and repair of roads East of canal.
8. The detachment of three Officers and 80 O.R. 1st Australian Tunn. Co. which will search for mines in captured territory, will by Zero be located in W. 6. c. & will move forward when ordered by C.R.E.
9. Detailed instructions regarding all work will be issued separately.
10. Headquarters 46th Division at Zero will be at Molain W. 15. d. 9. 9.

J. Marshall
 Capt. & Adjutant R.E.
 46th Division.

W.S. 2/11

APPENDIX N^o 4

18

- W.S. 2/11
- 253 1st Aust. Inf. Coy A.I.E. ✓
- 254 " " " "
- 256 " " " "

When a building, station, yard, bridge or other definite locality has been examined for mines, the Coy making the examination will erect a conspicuous notice

THE AUSTRALIAN TUNNELLING COMPANY.	
No.	S/357
Date	2.11.18

examined by ~~253~~ 253 1st Aust. Inf. Coy
date
ALL CLEAR
or charges unfused, but
still in position
etc, etc

This will save units being sent to search places 2 or 3 times by different people.

2/11/18

W.S. 2/11
Capt R.E.
Adj. for R.E. 9th Coy troops

354

W. O.
 Exp by 1st Auston G.
 Date
 All or
 Keep Out

Side of
 Brown
 to

11/11/1918

APPENDIX

4

354

APPENDIX N^o4.

1.

SECRET.

C.E. IX Corps/E.2019/51.

O.C. 1st. Australian Tunnelling Coy.,
Australian Engineers.

CHIEF ENGINEER, IX CORPS.	
No.....
Date.....

MINE SEARCHING.

Will you please arrange that reports on areas which are searched for mines, during forthcoming operations, are sent as soon as practicable to C.R.E., IX Corps Troops, and repeated to C.E., IX Corps.

This is important in order to prevent unnecessary overlapping in subsequent searching.

It is, of course, understood that such reports will be made in the first instance to Divisions concerned.

J. Tosh

Captain, R.E.,
for Chief Engineer, IX Corps.

2:11:18.

- Copy to:-
- C.R.E., 1st. Division.
 - C.R.E., 32nd. Division.
 - C.R.E., 46th. Division.
 - C.R.E., IX Corps Troops.

Surveyor
MWD
STL
2/4

1st AUSTRALIAN TUNNELLING COMPANY.	
No.	5/554
Date.	2.11.18.

354

SECRET
R/59

To C.O.Ist.Australian Tunnelling Coy,A.E.

In the event of successful operations and a further early advance be prepared to reconnoiter report on and be responsible for repair and improvement and maintenance of the road :- Ors - L.29.b.2.1. - G.15.d.8.1. and into Landrecies. Ors - L.34. b.1.8.- L.29.a.3.2.- L.29.b.2.1. or as much of them as the situation permits. Keep in touch with C.R.E.32nd.Div. as regards situation and the requirements of this division on this line of their communications. Keep me fully informed of what you do and of any requirements you cannot meet and locations of detachments.

2-11-18

Sgd.W.Traill
Lt.Colonel R.E.
C.R.E.IX.Corps Troops.

Disposal of German Explosives found in captured Territory

If explosives in really good condition are found in captured Territory and worth storing, store them properly and mark store distinctly and report thereon giving location. All other German explosives are to be destroyed.

4-11-18

Sgd. Captain R.E.
Adjt. for C.R.E.IX.Corps Troops.

SECRET.

R/65.

To C.O.Ist.Australian Tunnelling Coy.A.E.

The portion of your Company not detailed for Divisions will await further orders - and should be ready to move as strong as possible at short notice.

3-11-18

Sgd.W.Traill
LT.Colonel R.E.
C.R.E.IX.Corps Troops.

S E C R E T

1st. Divisional Engineers Battle Instructions

5th. Series

No. 1.

- 354
1. (a) On a date Z. which has been communicated to all concerned, the 1st. Div. is forcing the passage of the SAMBRE - OISE Canal between Petit - Cambresis and Catillon, zero hour being in the early morning.
 - (b) The attack is to be carried out by 2nd. Inf. Bde. on the right & 1st. Inf. Bde. on the left; the 3rd. Inf. Bde. is carrying out a Subsidiary and simultaneous operation to capture CATILLON and to form a Bridge Head there
 - (c) Map issued herewith shows objectives, inter-divisional boundaries, and inter-Brigade on 1st. Div. front.
 - (d) 46th. Div. is in Corps Reserve and its head is to be on the line of the MAZINGHIEN - BAZUEL Road by zero hour on Z day. Its role is to move by bounds asb the 1st. Div. progresses with a view to relieving the 1st. Div. either on the red objective or after any immediate exploitation which may be ordered during the operations, has been completed.
 2. (a) 2nd. Inf. Bde. group includes 2nd. Inf. Bde. and 409th. FIELD CO. R.E.
 - (b) 1st. Inf. Bde. group includes 1st. Inf. Bde. and 23rd " " "
 - (c) 3rd. Inf. Bde. group includes 3rd. Inf. Bde. and one Sec. 26th Fd. Coy. R.E.
 - (d) Under C.R.E.
 - 26th. Fd. Coy. R.E. (less one Section)
 - 6th. Welsh Reg. (Pars.)
 - One Section 1st. Aust. Tunn. Coy. A.E.
 - (e) D.E. H.Q. - VAUX - ANDIGNY.
 - Adv. Div. Report Centre - BELLEVUE X.13.a.
 - to which messages to C.R.E. will be sent after zero plus 2 hours on Z day.
 3. (a) The assembly of 23rd. and 409th. Field Coy's. and the Section 26th. Field Coy. attached 3rd. Inf. Bde., will take place under instructions issued by B.G's concerned.
 - (b) 26th Field Coy. R.E. (less 1 Section) will assemble in the neighbour hood of W.24., to be in position by zero plus one hour on Z day.
 - (c) The penteen equipment vehicles, fully loaded, of all Field Coy's will be brigaded and will come under the orders of O.C. 26th. Field Coy; they will assemble at the same place and time as that Coy.
 - (d) 6th. Welsh (Pars.) will be ready to begin work from zero plus one hour on Z day.
 - (e) Section 1st. Australian Tunnelling Coy. A.E. will assemble X.5.d.7.3. They will not reach assembly position before 03.00 nor later than 06.00 ~~on Z day~~ Z day.
 - (f) Strictest attention to march discipline and correct distances will be enforced in all assembly movements.
 4. (a) The details of bridging operations in connection with the attack are contained in the project already issued by C.R.E. 1st. Div.
 - (b) Section of 26th. Field. Coy. R.E. attached 3rd. Inf. Bde. will be responsible for the construction of Infantry foot bridges at CATILLON. The construction of transport bridges at this place ~~is being undertaken by IX. Corps~~
 - (c) Crossing No. 1. - 2nd. Inf. Bde.
 - Main Crossing Lock S.I.d.
 - Subsidiary Crossing in S.7.a.
 - Crossing No. 2. - 1st. Inf. Bde.
 - Main Crossing in M.31.a.
 - Subsidiary Crossing in M.26.c.
 - (d) Technical instructions on the bridging operations have been issued by C.R.E. 1st. Division to all concerned

4/-----

- (a) C.R.E. 46th. Div is arranging to throw three medium pontoon bridges over the canal between N.31.d.4.5. and S.1.d.5.8. These bridges will only be fit for Infantry, but it is hoped that on Z plus one day, they may be fit for artillery.
- (f) C.E. IXth. Corps is arranging for the following bridges on 1st. Division front -
- | | | |
|------------|-------------|---------------|
| CATILLON - | M.19.b.8.7. | for Tanks |
| | S.9.d.2.6. | for "A" Loads |
5. 6th. Welsh will reconnoitre and develop roads, in accordance with the tactical situation as follows :-
- West of the Canal
- MAZINGHIEN - CATILLON
 REJET-de-BEAULIEU - CATILLON
 " - Canal bridge in S.9.c.
 H.T. route from REJET-de-BEAULIEU to Lock S.I.d.
 East of the Canal.
 PETIT-CAMBRESIS - HAUTREVE - CATILLON
 H.T. Route from Lock S.1.d. to above road.
 HAUTREVE - LARGROISE
 HAUTREVE - BERGUES
6. Section of No.1. Australian Tunnelling Coy. will be available to search for Mines and Traps east of the canal, when bridging operations are completed.
7. Engineer reconnaissance as regards roads, bridges, water supply mines, dumps etc.; will be carried out by Field Coy's and Pioneer Batts.
8. "B" Echelons of Field Coy's transport will remain in their present Locations.
9. During the operations all co-ordinate map references will be made to the 1/20,000 Scale Map (message maps and)
10. (a) 23rd. and 409th. Fd. Coys will synchronize watches on one day by arrangements with Bdes to which they are respectively attached.
 (b) 26th. Fd. Coy. will send a representative to 1st. Div. E. H.Q. for that purpose on "Y" Day at 1900.

Sgd. Lt. Colonel
 C.R.E. 1st. Division B.E.F.

Chief Engineer LXth Corps
E.A. 1.

C.R.E. LXth Corps Troops
O.C. 1st Australian Tunnelling Company

EXTRACTS FROM INTELLIGENCE INFORMATION

STREE Ammunition dumps on the Station platform.

THULLIES. 80 to 100 wagons loaded with ammunition and war material of all kinds; many dumps, and 'planes. The Station is in the centre of the town, so there is great danger to the inhabitants and houses.

CHARLEROI According to one official from this town, there are many dumps which have been blown up by the enemy since the Armistice has been signed.

From Statements made by an escaped civilian .

On the BEAUMONT - CHARLEROI Road every bridge is prepared for mining, main bridges have charges already laid, and not difficult to locate.

Main cross roads have holes (5' x 6' by 8' deep) dug ready for placing mines

(Sigd) J. TOSH Capt. RE.
For C.O. LXth Corps.

MEDICAL ARRANGEMENTS Continued.....

GROUP 54
OF C.C.Ss.

SICK. (c) Light Cases will be evacuated in the same manner as the Walking Wounded (see para. 11 (a)).

(d) Severe cases to the BOHAIN GROUP of C.C.Ss.

(e) Special cases (N.Y.D., N - N.Y.D., Gassed -S.I.W.-Venereal - Dysentery) to the 58th.U.C.S. TINCOURT, via Corps Main Dressing Station and Corps Walking Wounded Staging Post HOSPICE BOHAIN.

(f) Local sick, BOHAIN, to the Corps Walking Wounded Staging Post HOSPICE BOHAIN, where Field Medical Units Cards and A.F.W 3210 will be made out. The A.F.W. 3210 will be forwarded daily to the Central Bureau Corps Main Dressing Station., L'ARBRE DE GUISE.

111. LOCATION OF FIELD AMBULANCES, etc.

1st Division	(1st Field Ambulance...)	FRESNOY LE GRAND.
	(2nd " ")	FRESNOY LE GRAND (Convent.).
	(141st " ")	L'ARBRE DE GUISE (C.M.D.S.)
6th Division	(16th Field Ambulance..)	BOHAIN Girls School D15.d3.4.
	(17th " " ..)	BOHAIN Rue Jean D'Arc. D21.a.3.7.
	(18th " " ..)	BUSIGNY V10.d.0. 4.
32nd Division	(90th Field Ambulance..)	LE GRAND FAYT -I.26.c.
	(91st " " ..)	FAVRIL N2 N.2.a.9.7.
	(92nd. " " ..)	CATILLON SUCRERIE R.23.b.1.8.
46th Division	(1/1st N.M. Field Ambulance..)	CATILLON M19x M.19.b.4.4.
	(1/2nd " " ..)	MEZIERES, M21.b.7.7.
	(1/3rd " " ..)	CATILLON M.19.b.4.4.
A.D.M.S. 1st. Division...		FRESNOY LE GRAND I.18.a.9.3.
A.D.M.S. 6th " ..		BOHAIN D.21. b.4.8.
A.D.M.S. 32nd. " ..		FAVRIL N2 N.1.b.
A.D.M.S. 46th " ..		PRISCHES, N.17.d.3.4.
23rd Sanitary Section		FRESNOY LE GRAND.
58th " "		BUSIGNY V.17.c.1.4.
61st. " "		MONTBREHAIN C.25.d.7.5.
77th. " "		BOHAIN
44th M.A.C.		BOHAIN moving to CATILLON R.23.b.1.8.
18th Advanced Depot Medical Stores..		BOHAIN C.5, b.

Sgd. H.W. GRATAN

Colonel

A/D.D.M.S. IX Corps.

Headquarters IX Corps.
7th November 1918.

L.
Distribution.- Lists "A". "B" and "C"

354

APPENDIX 4

APPENDIX N°4.

SECRET. 9

IX CORPS
MEDICAL ARRANGEMENTS NO.64.
by

COLONEL H.W.GRATTAN?D.S.O. a/D. D.M.S. IX CORPS.
-----00-----

Reference Map Sheets 57A,57B and 62B.

I. LOCATION OF MEDICAL FORMATIONS.

Left Divison :

Advanced Dressing Station ... LE GRAND FAYT -1.26.c.
Walking Wounded Post.

Right Division.

Advanced Dressing Station...CARTIGNIES -0.11.a.7.3.
Walking Wounded Post...MEZIERES - M.21.b.7.7.
Car Post...PRISCHES - N.17.d.3.4.

Corps Main Dressing Station..L'ARBRE DE GUISE- Q.35.d.
Corps Walking Wounded Station ..moving from BOHAIN to the
SUCRERIE, CATILLON- R23.b1.8.

Corps Walking Wounded Staging post. HOSPICE BOHAIN
D.22.a.6.1.(16th Field Ambulance.)

Corps Rest Station.. BOHAIN, D.15.d3.4.(closed.)
Casualty Clearing Stations.

Stretcher Cases..... Nos.20, 50 and 61,BOHAIN -
GROUP- C5.b. and D.7. Cent.

Walking wounded and slight
cases of sickness... Nos,5 and 47.- BIHECOURT.

II. EVACUATION OF SICK AND WOUNDED.

WOUNDED. (a) Walking wounded will be evacuated to the
Corps Main Dressing Station,L'ARBRE DE GUISE. where
they will be dressed, fed, receive A.T?S.and have
their particulars taken. They will be evacuated
thence to C.C.Ss.at BIHECOURT., via the Corps walking
wounded Staging Post the HOSPICE BOHAIN. It is
anticipated that the Corps Walking Station will
re-open at the SUCRERIE CATILLON at 0900 hours 9th
inst. if not before.

(b) Stretcher Cases to the Corps Main Dressing
Station,L'ARBRE DE GUISE, thence to the BOHAIN GROUP

354
COPY

C.E. LXth Corps

No. E/150/546

dated 13-11-18

REPORT ON ROADS

References refer to attached sketch map.

1. Commenced by civilians. Fair single traffic route. Now taken over by 130 Field Company R.E. 25th Division.
2. Crater being filled in and Box Drain being made to replace culvert. Good diversion round past church.
3. Double traffic route made round North Side. Corduroyed with German Mining Cases. Being filled in on Southern side. Good for Motor lorries.
4. Being bridges for all traffic except tanks. Present bridge for single traffic only. Culvert damaged, has to be cleared on completion of bridge.
- 5) Being filled in. Open for single traffic, but will not stand heavy traffic
- 6) traffic at present.
7. Filled in. Road good. Culvert damaged. This will have to be attended to.
8. Filled.
9. Bridged for lorries.
10. Bridges. (Not seen done by 12th Lancers)
11. Bridged of 9 ton axle load.
- 12 Crater filled. Requires further top dressing of stones. Culvert requires clearing, box drain being put in lower down the road to take flood water which has collected.
13. Mines removed. 7 H.T.M. Shells.
14. Bridged for all traffic except tanks.
15. Crater being filled in - not complete.
- 16) Craters - nothing done.
- 17)
- 18) Will be filled in by Midday tomorrow. But will require corduroy, if required to take lorries. Traffic can now pass.
- 19) corduroy, if required to take lorries. Traffic can now pass.
- 20 Bridge (Rough for first line transport) made entirely from timber felled for the purpose)
- 21 Mine removed.
- 22 Mine removed. Six shells of various sizes.
- 23 Mine removed.
- 24 German saw mill - Great number of logs. Chiefly hardwood, oak, & Beach. Some planking, light scantling and great quantity of Mining frames. There-are

There are a large number of mining Frames at SOLRE LE CHATEAU Station. There was a small amount of timber also, but this had been chiefly used for bridging. Timber at SANS POTERIES Station has also been used for bridging.

Additional road mines have also been removed, but I have not the location at present, will advise later.

All roads shown coloured are open to traffic.

13-11-18

(SIGD) ??? DAVIES Lieut. Col. RE.
C.R.E. 66th Division.
No. 44/19.

APPENDIX

4

Reference Namur Sh. 8 1/100,000

354

Craters or bridges blown }
 no repair }
 Gaps made Passable }
 Mined }
 Mine removed. }
 Reported by escaped French }
 prisoners as mined some of which }
 are believed to have been blown }



Appendix No 4

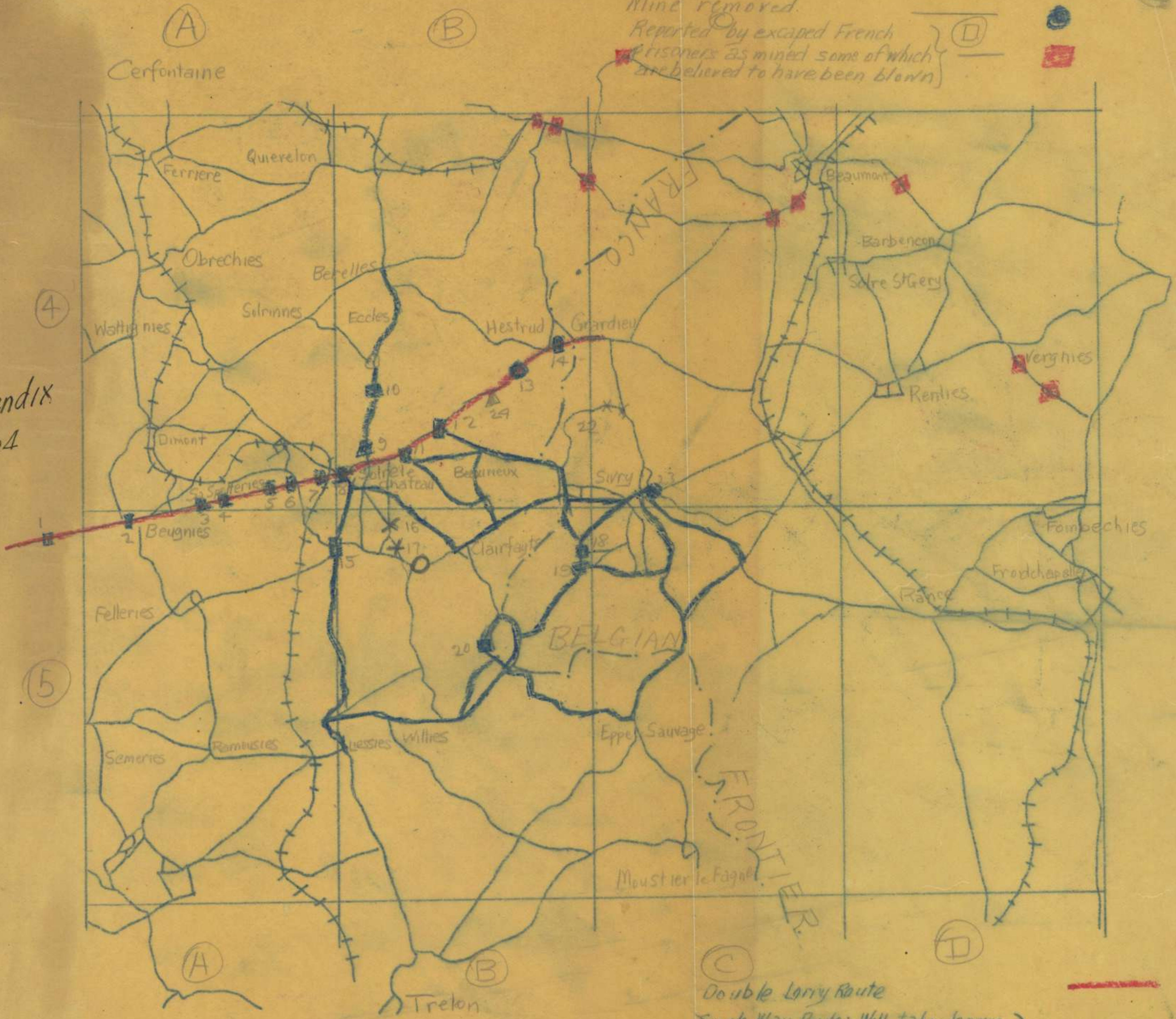

(C) Double Lorry Route
 Single Way Route: Will take lorries }
 but only suitable for horse transport }



APPENDIX

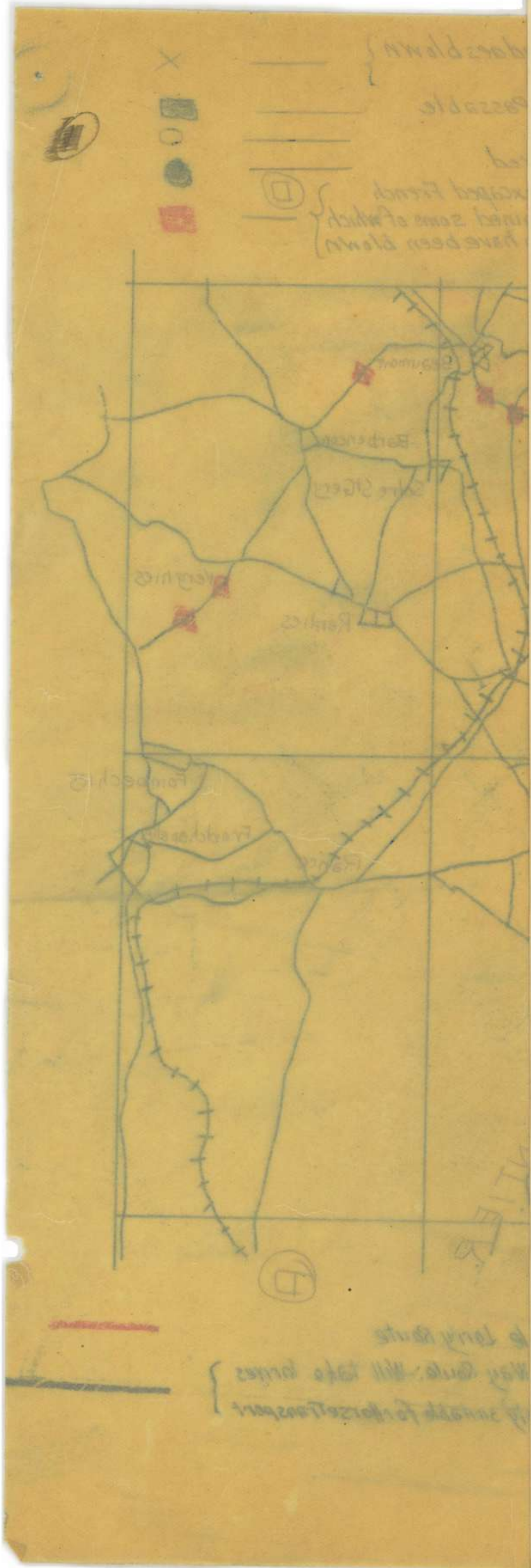

EXAMINATION OF PILOT OF 84th. SQUADRON WHO WENT DOWN
IN ENEMY LINES ON NOVEMBER 10TH. NEAR MARIENBOURG.

The pilot was out low flying to machine - gun transport on roads when he was forced to land at N.W. of MARIENBOURG at 15.00 on Nov. 10. He landed among a number of Germans of F.A.R. 29 who took him prisoner. He was taken to the Batt. H.Q. at MARIENBOURG. He did not notice which Reg. this belonged to but it belonged to the 26th Inf. Div. He was sent to the Div. H.Q. at VILLERS-LES-GAMBON on 11th Nov. He was kept here till Nov. 13th., the Germans not knowing whether to let him go or not. The Div. H.Q. left VILLERS-LES-GAMBON on the 13th. and went North. They were followed by a transport column who said they were the very last of the Germans. Field Guns were in position near ROLY on 11-11-18. An A.A. Battery left VILLERS-LES-GAMBON to the north on 12-11-18. The pilot was allowed to go free and obtained a cart and drove to our lines going through PHILLEBOVILLE, SILENRIEUX, ERPON, VERGNIES, RENLIES, SAUTIAN. The last Germans were last seen on the morning of the 13th. near VERGNIES packing up. British out-posts were met near SAUTAIN. Belgians at PHILLEVILLE and SILENRIEUX said the Germans were en-training.

LIVE-STOCK Between SILENRIEUX AND PHILLEVILLE the pilot saw Germans taking cattle and furniture away with them on the 13th. Nov. A large number of cattle, driven from France and abandoned were seen in the field between BOUSSU and VERGNIES. The Belgians appeared to have sufficient food now.

ROADS Single M.T. Roads .

MARIENBOURG-ROLY) SAUTOUR-VILLERS-LES-GAMBON. The road bridge over stream immediately West of MARIENBOURG is mined was not blown on 11-11-18.

The road VILLERS-LES-GAMBON - PHILLEVILLE) SILENRIEUX - BOUSSU is a good double M.T. Route not blown up anywhere. It had a continuous single stream going in on 13-11-18.

The railway bridge going over the stream just east of SILENRIEUX has had all the cross bearers removed though the rails and girders are intact and should be carefully examined before use.

The road BOUSSU - ERPION) VIRGENS - RENLIES - SAUTIAN is a good single M.T. Route .

there were no craters blown on any of these roads.

CIVILIANS There were large number of French civilians moving west to their homes.

TELEGRAPH LINES. In towns have been left intact.

IX. Corps Intelligence.
14-11-18.

APPENDIX NO.4.

23

C. of M. 4th. Army
28/496
17-11-18Ist. Australian Tunnelling Coy A.E.

The following wire is forwarded for your information.

C.E. 4th. Army.

B.27.

16.

AAA

"Following wire sent to all Armies from A.G. begins senders number
 A.B.123 dated 16/11 AAA A proportion of German prisoners may be
 used to assist the parties engaged in discovery and destruction of
 Mines and D.A. fuses placed by the German Army AAA ends AAA
 Addressed C.E. all Armies Repeated C. of M. all Armies.

E. in C. G.H.Q.

Sgd R.E. Hill Lt. Colonel R.
C. of Mines 4th. Army

354

*1-2-3
B. Pass*

to 200 APPENDIX N^o 4.
*No. 2. 24
193 R.H.*

13

IX CORPS ROUTINE ORDERS
BY
LIEUTENANT GENERAL SIR WALTER BRAITHWAITE, K.C.B.
COMMANDING IX CORPS.

16th November 1918.

ADJUTANT GENERAL'S BRANCH.

473. GERMAN DOCUMENTS.

A quantity of useful information has been obtained from papers and maps left behind in offices and depots of German Electric Power Companies and Detachments ("Starkstrom Kompagnien" and "Starkstrom Abteilungen").

2. As far as possible, the papers and documents found should be preserved and, later, sent in to Corps Intelligence for examination, with particulars as to where they have been found. Town Majors should be asked to prevent the destruction of such papers if the houses are wanted as billets and offices. The preservation of these documents will often enable useful material to be found. This will also assist the industrial reconstruction of the area later on by helping owners to obtain possession of their plant which has often been moved about by the Germans to suit their work.

3. The sites of "Starkstrom" "Abteilung" Offices, etc., will usually be found on the maps of German town commandants.

474. MINES - EXPLOSIONS.

Reports will be submitted to Corps Headquarters of all explosions which occur in the territory now neminally in German occupation, giving all possible particulars.

1st AUSTRALIAN TUNNELLING COMPANY.	
No.	9776
Date	20-11-18.

J.C. HARDING NEWMAN,
Brig-General,
D.A. & Q.M.G., IX Corps.

150/214

C O P Y

(1)

Fourth Army No.
G.T. 110

XXXXXXX

XXXXXXX

11th Corps.

1. The Army Commander wishes to call the attention of all commanders to the following points upon which the Field Marshall Commanding in Chief has laid great stress.

2. Breaches of discipline must be repressed firmly and at once. At the same time the necessity for avoiding irritating restrictions must be impressed on Officers, as there are a number of officers with our Army at present who lack experience. The reason why certain things are not permitted should be explained.

3. Leave to visit places of interest should be granted freely to all ranks, and the necessary transport arranged.

Visits should be arranged between detachments of the various arms.

4. It is the duty of Regimental and other Officers to organise and direct the amusements for their men. Funds to provide games, etc. will be provided on application to A.H.Q. if Divisions are unable to do so. A Pamphlet describing different games, home, colonial and foreign - is being compiled at G.H.Q. and will be circulated. The Superintendent of Physical and Recreational training, 4th Army, is arranging for an immediate issue of Recreational Kit (footballs, boxing gloves, and running shorts) to be made to Corps and to Army Troops.

Money prizes may not be given for boxing (vide G.R.O. 2059 dated Jan. 7th 1917), and the Army Commander has expressed the wish that no money prizes should be given, for any athletic events; medals and trophies should be given.

The Superintendent of Physical and Recreational Training, with the Staff of Officers and Instructors will be glad to assist formations if they so desire, and will, if requested, forward circulars and pamphlets on the Organisation of sports and athletics.

5. Every cantonment should be provided with recreation rooms and canteens.

6. Ceremonial parades will be held when the weather is fine. The Field Marshall Commanding in Chief or Army Commander will attend when possible.

7. Lectures on " After the War Problems should be arranged. A pamphlet on Demobilisation will be issued to the Army very shortly.

8. The restrictions on the use of cameras are cancelled.

9. Regulations as to Censorship will be relaxed. Men will now be allowed to describe where they are and the nature of their surroundings.

(Sgd. A.A. Montgomery Major
Genl.

14-11-18.

G.S. 4th Army.

(2)

G's C Sections.

For your information and necessary action, please.

21-11-18.

Lieut. AE.
For C.O. 1st Asst. Tunn. Coy. AE.

APPENDIX N^o4

C of M 4th. Army
37/614
26-11-18

20

254
C. Ist. Aust. Tunn. Coy. A. E.

Herewith copy of order sent to Australian Corps.

The transfer of your Unit from IX. to Australian Corps takes place at 23.59 on 28th. inst.

Will you please make arrangements to move your H.Q. to MARBAIX or vicinity as soon as possible.

Attached are orders for work ~~XXX~~ by your Unit.

Please arrange to put this in hand as soon as possible, arranging for Sections to be billeted at convenient centres.

Sgd. T.E. Hill Lt. Colonel R.E.
C. of Mines 4th. Army.

APPENDIX NO. 4.

WORK ORDERS

IST. AUSTRALIAN TUNNELLING COMPANY A.E.

21

1. Culvert at SOLRE-LE-CHATEAU to be completed.
2. Road Metal to be quarried at HESTRUD and GRANDRIEU (see attached letter).
3. Galleries under roads near DONSTIENNES to be filled in at 3D.65.45. and 3D.76.42. (between CHARLEROI and BEAUMONT).
4. Charges to be removed from Bridges at FONTAINE VALMONT and LOBBES (as instructed to-day).
6. Reconnoitre the area shown on attached Map, and search for D.A. and other Mines, paying particular attention to Railways. Remove all charges, and fill in shafts and galleries.
7. Arrange for a D.R. to report to C.E.'s office A.H.Q. daily at 10.00 and 20.00 until further notice.

C of M. 1/617
26-11-18

Sgd. T.E. Hill Lt. Colonel R.E.
C. of Mines
For C.E. 4th. Army.



354
APPENDIX NO.4.

• 22

Cof M. 4th. Army
1/616
26-11-18

O.i/c Detachment,
1st. Aust. Tunn. Coy. A.E.

Please arrange with bearer to assist in quarrying road metal at GRANDRIEU and HESTRUD.

As stone is urgently required men may be withdrawn temporarily from working on the culvert at SOLRE-LE-CHATEAU until additional men are furnished from your Company H.Q.

Please let your O.C. know at once if any special tools or stores are required, also number of additional men required.

Sgd. T.E. Hill Lt. Colonel R.E.
C.of Mines 4th. Army.

354

APPENDIX NO. 4

15
 C.E.IX.CORPS /E.A.6/7
 C.E.4th.ARMY /E.159.

C.E.4th.ArmY

Charges have been removed from Mine galleries under the road near DONSTIENNES.

The galleries are timbered with mining frames and are safe for traffic, but will eventually require plugging before the timber rots.

May A.D.Roads be informed accordingly, please.

24-11-18

Signed R.A.Gillam BRIG.GEN.
 C.E.IX.CORPS.

(2)

C.E.IX.CORPS.

Reference your E.A.6/7 dated 24-11-18 :-

This is not a matter of road maintenance but the repair of Military damage.

Please carry out the work with men of the Tunnelling Coy. attache to your Corps, and report completion.

A.H.Q.25-11-18

Signed R.U.H.Buckland
 Maj.Gen.C.E.4th.ArmY.

(3)

O.C.Ist.Aust.Tunn.Coy..

Please have the work of filling in these galleries taken in hand after you reach your new location to-morrow, and report completion through Australian Corps.

DONSTIENNES is about 4 miles N.E. of BEAUMONT, on the CHARLEROI Road.

27-11-18

Signed R.A.Gillam Brig.Gen.
 C.E.IX.CORPS.

Inspector of Mines No. 2439

354 To/

Controller of Mines 4th Army.

I should be glad if you would obtain from Companies in your Army the following information :-

1. No. of Bridges Heavy and Light, constructed since 8th of August.
2. Revised totals of Traps etc. removed since 8th of August as under :-

Land Mines.
Anti-Tank Mines
D.A. Mines.
Other Traps.
Enemy Demolition Charges.
Total weight of explosives removed.
Gas Shells removed.
No. of British Demolition charges removed.
Total weight of British demolition charges removed.

3. List of immediate honors and awards obtained by Companies since 8th of Aug.

This information is required as a check on my figures with a view to publication amongst those concerned.

I shall be glad if you will ask O.C.'s Companies to make the information as definite as possible to facilitate compilation of a summary. Will you please let me have it not later than 10th of Dec.

G.H.Q. 25-11-18.

Sgd. H.R. Dixon Capt. R.E.
for Inspector of MinesC. of M. 4th. Army
1/633
28-11-18To/
O.C. 1st. Aust. Tunn. Coy. A.E.

Above information for your information and necessary action.

Will you please let me have answer to above three questions not later than Dec. 3. Special notes should be made of Officers and O.R.'s who have been recommended for immediate awards, in cases where none of the particular batch have been yet awarded.

Sgd. T.E. Hill Lt. Colonel R.E.
C. of M. 4th. Army.

[Handwritten initials]

APPENDIX N^o4.

C.E.IX.Corps.
E.A./6/9 ¹⁶

354
Controller of Mines 4th Army.
C.E. 4 th. Army. (for information).

The following further report on mines which has just been received from C.R.E. 1st. Division is forwarded for favour of necessary action if these mines have not already been dealt with by you :-

"The following results of investigation of suspected mines have been reported.

(a) The tops of 2 Shafts are visible at 3D.22.52. near STREE and there are no signs of the charges haveing been removed. These charges were repprted by Civilians, but time was not available to dig them out.

(b) XRoads 3D.22.56. near STREE. Conditions the same as in sub para (a) above.

(c) XRoads 3C.93.64. near Culvert. The charge had been removed by the enemy.

(d) XRoads 3D.08.42. near STREE. 2 Shafts are visible on each side of 2nd. class road leading East.

Farmer liveing in neighbouring house stated that 63 Shells had been placed in these Shafts and not removed; No time was available to dig them out.

27-11-18.

C.E.IX.Corps.

Signed R??Gillam Brig. Gen.

354

APPENDIX 4

APPENDIX N^o 4

17

1ST AUSTRALIAN TUNNELLING COMPANY A.E.

Headquarters
30/11/18.

Officers Commanding
Sections.

Following copy of memo. from Controller of Mines
is forwarded for your information please:-

" DESTRUCTION OF EXPLOSIVES "

"All captured explosives other than those required for use,
should be destroyed by scattering over the ground. They should
not be thrown into ponds or streams, for fear of poisoning them."

(Sd) L.F.Hill, Lt.Col. R.E.
Controller of Mines
Fourth Army.

L.F. Hill Lieut.A.E.
Adj. & Q.M., 1st Aust. Tunnelling Coy.A.E.

APPENDIX No 4
21 1918

APPENDIX

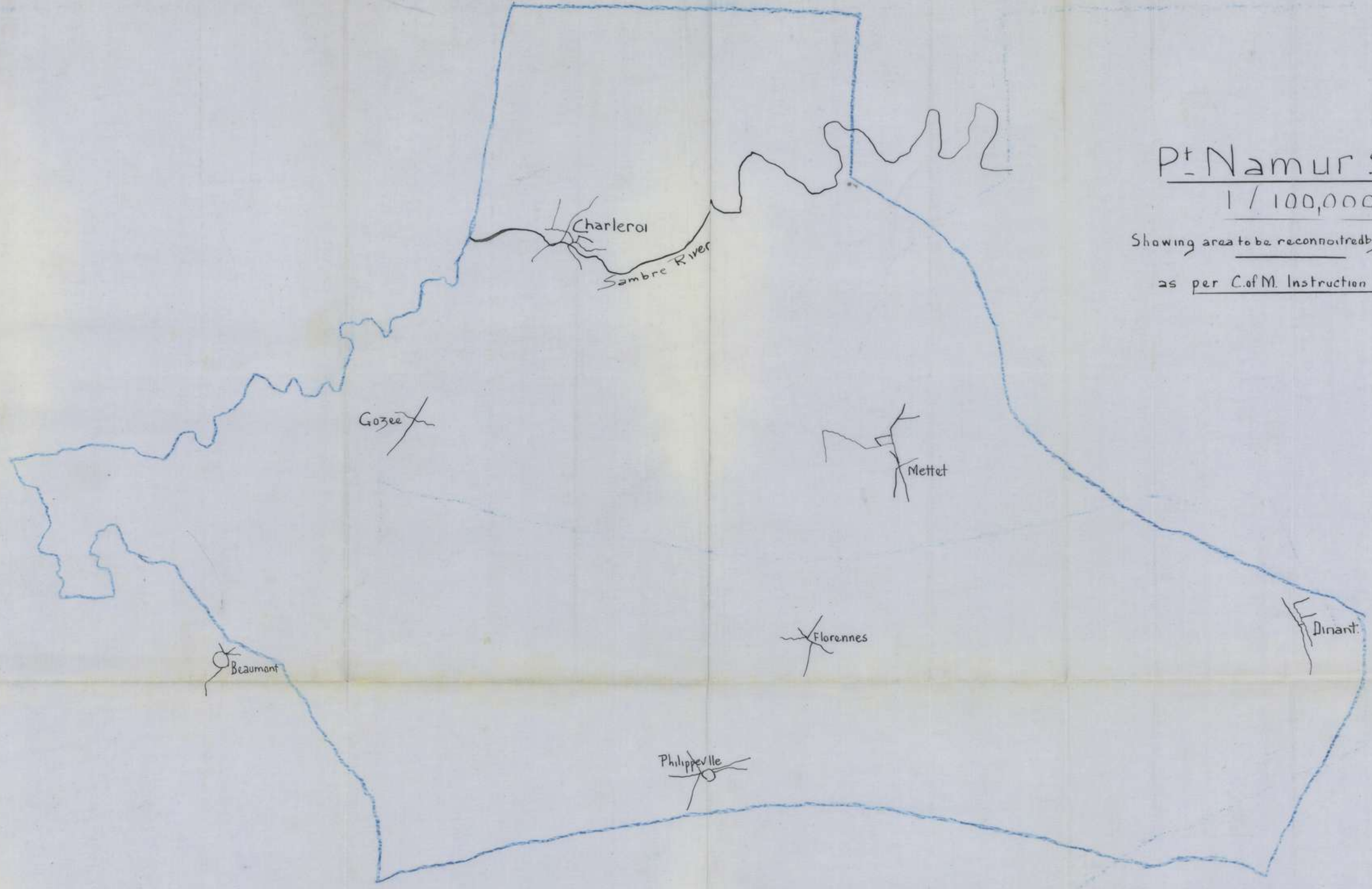

Pt Namur Sh 8
1 / 100,000

Showing area to be reconnoitred by 1st Aust Tunn Coy
as per C of M. Instruction 1/617 of 26.11.18

APPENDIX 4

328
APPENDIX 4
5

as per C of M instruction 1617 of 28-11-18
Showing area to be reconstructed by Aust Turm Coy
1/100,000
P. 1 Namur 2-8

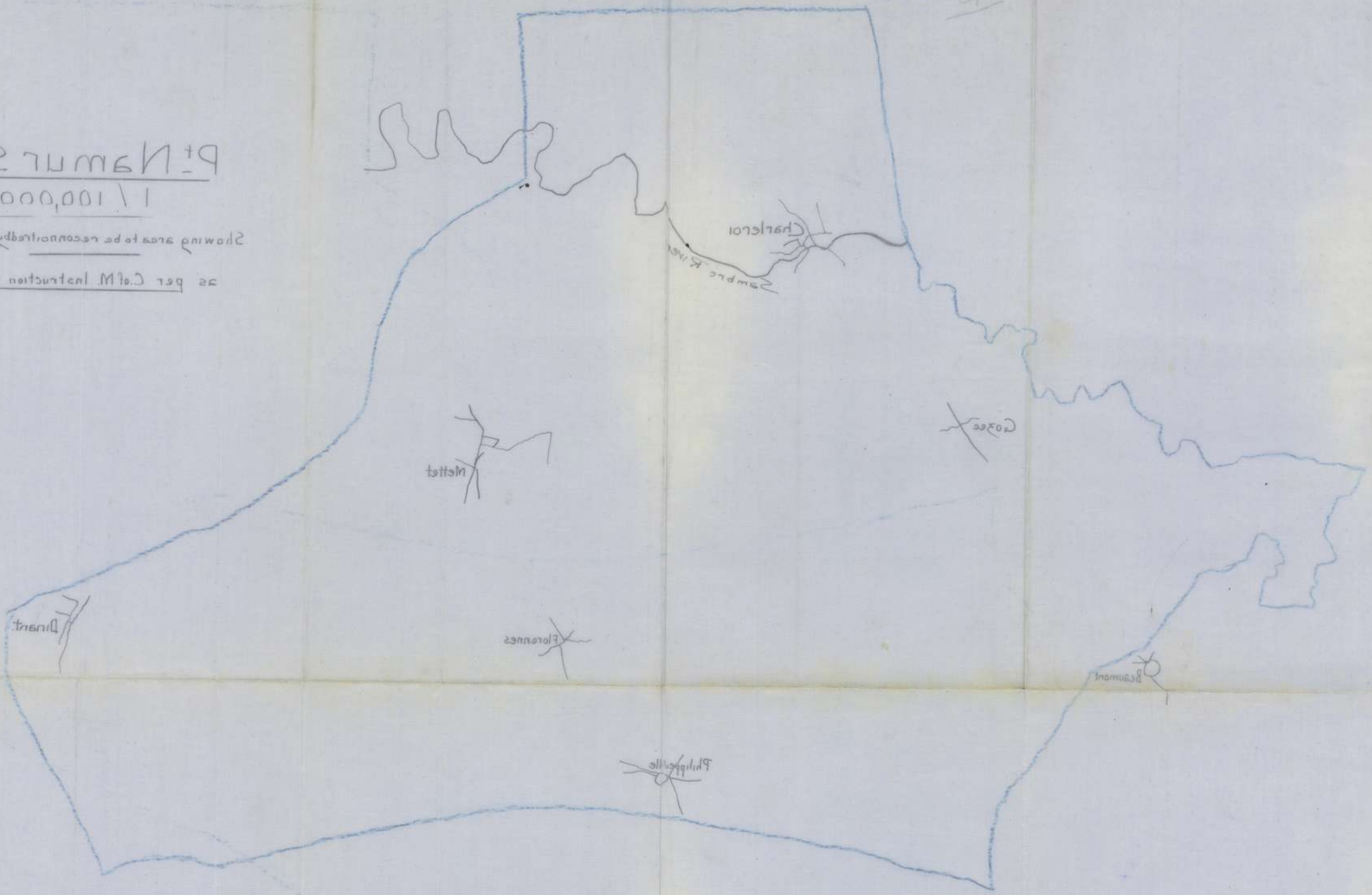



35A

APPENDIX NO. 5.

1ST AUSTRALIAN TUNNELLING COMPANY A.E.

OFFICERS AND OTHER RANKS SENT TO INSTRUCTIONAL SCHOOLS DURING

NOVEMBER 1918.

Nov. 6th. Lieut. C.H.J. CLAYTON, to R.E. Training School at ROUEN.

354

APPENDIX

6

APPENDIX N° 6

5

CF/AG.

CHIEF ENGINEER AUSTRALIAN CORPS. NO. 41/331

3rd. November. 1918.

1st. Australian Tunn. Coy.
2nd. Australian Tunn. Coy.
1st. Aust. A. T. Coy.

The Chief Engineer Fourth Army has passed to me a copy of a personal letter from the Engineer-in-Chief, and it gives me great pleasure to transmit it to you.

1st AUSTRALIAN TUNNELING COMPANY.	
No.	41/331
Date	6.11.18.

C. H. Foon

Brigadier-General.
Chief Engineer. Australian Corps.

APPENDIX N° 6

1

O.C.

1st Australian Tunnelling Coy. A.E.

The Engineer-in-Chief wishes me to convey to you his thanks and congratulations on the splendid work which you have done in searching for Mines and Traps, a duty involving great personal risks but of the utmost value to the other arms of the Service.

Please convey this^{to} all your Officers and men and add my congratulations to those of the C-in-C

W. H. H. H.

Lt. Col. R. E.

C.R.C. T. Corps Troops.

2.11.18.

The following Special Order of the day issued by Major General Strickland C.B., C.N.G., D.S.O. Commanding 1st. Division is published for the information of all ranks :-

The task that the Division was called on to perform yesterday was one entailing the utmost forethought for every detail, the most careful and precise Staff Work in all branches, a thorough and precise organisation in Btas., of the most minute detail and gallantry, tact and endurance on the part of all troops engaged.

The complete success of the operations is very greatly due to the skill, ability, rapidity and completeness with which the bridging arrangements were completed and perfected. I wish to pay special tribute to LT. Colonel C. T. Sankey D.S.O. his Field Company Commanders and all ranks of the R.E.'s., and Section 1st. Australian Tunnelling Company A.E. for the part they have played in these operations. The cool gallantry with which they placed the bridges in position under heavy fire after long and arduous hours of labour, was magnificent. After these severe ordeal they were engaged for the rest of the day in Bridge Building under fire, without which the operations could not have been completed.

They have very worthily upheld the very high traditions of the Royal Engineers.

I cannot sufficiently express my admiration and thanks to all branches of the Staff and to all Units in the Division for their unsurpassed efforts of the last three weeks culminating in as fine a military achievement as any Troops could have carried out.

The Division on a whole has every reason to be more than proud of their record and they could not have done more than upheld as they have done the brilliant record of the 1st. Division of the British Army.

5-11-18.

Sgd. ? STRICKLAND Major General
Commanding 1st. Division.

354

APPENDIX 6

APPENDIX N° 6

3

Lt-Col. W. Garforth, DSO, MC.

Acting CRE, 46th Division.

46th Division G.117/118. 9th November, 1918.

The Divisional Commander wishes to congratulate you and the Field Companies under your Command on the excellent work carried out during the last few days.

Please inform all ranks of the Royal Engineers that their efforts have been highly appreciated.

Will you also please convey to Major Wilson, Comdg 258th Tunnelling Company, RE, and to the OC, 1st Australian Tunnelling CO, the thanks of the Divisional Commander for the valuable services rendered by their respective companies.

the section of

Handwritten signature

Lieut-Colonel,
General Staff, 46th Division.

Copy to 137, 138, 139 Inf. Bdes.

Order

354

APPENDIX 6

APPENDIX N° 6

3

O.C. 1st. Australian Tunn. Co. A.E.

(1) I have much pleasure in forwarding the enclosed letter, received from the Divisional Commander on the recent work carried out by your Company.

(2). The G.O.C. is particularly pleased with the work done by Capt HINDER & his officers ^{and men} - all of whom ~~are~~ have displayed the keenest interest.

10/11/18

W. G. Griffith ^{Lieut-Col} of C.R.E. 46th Division

Order

354

APPENDIX 6

CHF/GH.

IN REPLY PLEASE QUOTE

APPENDIX N°6



TELEGRAPHIC ADDRESS ⁴
"ADMINAUST, LONDON."

CABLE ADDRESS:
"ADMINAUST, LONDON."

TELEPHONE:
VICTORIA 8860 (10 LINES).

AUSTRALIAN IMPERIAL FORCE.

Administrative Headquarters, A.I.F.,

130, HORSEFERRY ROAD,

LONDON, S.W. 1.

19th November, 1918.

My dear Anderson,

Owing to my having been posted direct to this job, it has not been possible for me to say "Goodbye" to you personally. Would you let me do so now and at the same time I should be very glad if you would tell your Officers, N.C.Os and sappers that I very much appreciate the loyal and gallant service rendered by them during the past 9 months.

I wish them all the best of luck and a safe return to Australia.

Yours very sincerely,

Major. E.S. Anderson, M.C.,
1st Aust. Tunnelling Coy.
FRANCE.

Dear Buckland,

I have received many reports of the fine work done by Engineers in recent bridging operations - especially in those operations involving a high degree of pluck and ingenuity in the face of the enemy.

I am sure the whole Corps at Home and Abroad and their opposite numbers in the Dominions when they hear of the way in which the obstacles were so gallantly overcome - will be filled with pride - Our congratulations are due to all those whose foresight and initiative has contributed so much to success.

Our thanks and congratulations are also due to the Tunnellers for their conspicuous success and gallantry in the searching out and removal of enemy mines - always a risky operation. Over half a million pounds of enemy explosives have been removed to date.

Yours sincerely
Signed G.M.Heath

C.E.IV.ARMY.E/158/13

Chief Engineer
Australian Corps.

For information.

sd.A.E.W.Webb Major.R.E.
Staff Officer to C.E.IV.Army

A.H.Q.31-10-18

C.E.Australian Corps.
3rd.November 1918.

To Ist.Australian Tunnelling Coy,

The Chief Engineer IV.Army has passed to me a copy of a personal letter from the Engineer in chief, and it gives me great pleasure to transmit it to you

Sgd.C.H.Festé
Brigadier General
Chief Engineer Australian Corps.

354

APPENDIX

7

APPENDIX NO 7.

Controller of Mines
4th Army.Inspector of Mines
No. 4181

3

The following extract from a report of Controller of Mines, 5th Army, on an explosion of 2 Road Mines of the type described in plate 5 Fig.1 of E.in C. Fieldwork Notes No.59 whilst being dismantled, which resulted in 3 Sappers being killed, is forwarded for information

It has been difficult to ascertain definitely the exact cause of the explosion in both cases as no-one in the vicinity was left alive to tell the tale, and after these accidents had occurred orders were given for the Road Mines not to be opened up and rendered harmless but to be carefully removed, and destroyed with explosives. The O.C., 250th Tunnelling Coy., informs me that he considers both accidents were due to the safety pin retaining the striker of Fuse Lighter being very delicately set (on the mouse trap principal) and greased, with the result that the vibrations caused by the withdrawal of the sliding block caused the safety pin to be completely withdrawn. All evidence obtainable points to this being the case and not to the introduction of some new device on the Booby Trap principal, which, on being dismantled explodes. Safety pins of German Fuse Lighters of the nature used in this type of Road Mines have been found elsewhere well greased so that a very slight shock will set them off. As however, the examination of Road Mines of this type is manifestly a very dangerous operation, orders have been issued to all Companies to remove and destroy them on discovery and not to dismantle them; consequently it has not been possible to obtain absolutely conclusive evidence of the cause of the explosion in the above mentioned case.

(Sd) D.W.Y. DANFORD, Lieut. Col.

Inspector of Mines

G.H.C.,
26/10/18.

Controller of Mines 4th Army.

Inspector of Mines
No 3943

- (1) The following particulars regarding Delayed Action Mines, are circulated for information:-

RAILWAYS. Delay Action Mines have been removed on 23rd and 24th October from BEHAIN (7) East of CAMBRAI (4), N.W. of EPENY (4), HEMIN - LIETARD. In all these cases except the last a 4' X 4' untimbered vertical shaft has been sunk 9' - 12' deep between the rails and undercut sufficiently to hold part of the charge.

The charge was roughly 1,00 lbs explosives packed in tin cases; rarely shells (x) See note at end. 1 delay action fuse of the 1 A/3152 type in each mine. The only indication of a mine was a slight subsidence of the ground. The HEMIN - LIETARD Mines consisted of 12" shells buried 4'6" under the rails at a level crossing and concealed under loose piles of stone.

Delay action Mines have exploded between HUEDECOURT and EPENY, 1 on 5th October, 1 on 10th Oct., 1 on 18th October. These as well as those removed unexploded from here (which were interspersed) were in an embankment. EPENY was occupied by us on September 29th ~~xxxx~~

ROISEL. 1 on 24th October at a Level crossing W. of village. ROISEL was occupied on 7th September.

CAMBRAI. 1 on 24th October, 2 on 25th October at the Junction and siding. CAMBRAI was occupied on 9th October.

DOUAI. 1 on 24th October at the Junction, E. of the town. Crater 60' in diam. formed. A surface demolition had been blown to cover the previous work. DOUAI was occupied on 17th October.

NORTH OF GOUZEACOURT. 1 on 22nd October. GOUZEACOURT was occupied on 27th September.

ROADS. Delay action Mines have been removed from the LENS - CARVIN (1) LENS - HARNES (2) and COURRIERES - HARNES (1) roads. The charge in each case was shells. The last named (at the road junction by HARNES Station) was driven from the cellar of a house which was blown down. Delay action Mines have exploded N.W. of DOURGES on 26th October. The charge contained Gas Shells.

MISCELLANEOUS Delay Action Mines have been removed from WATTINES CHATEAU 10 - 9" shells under a tiled floor, the tiles of which had been carefully replaced and covered with rubbish. Delayed action mines have exploded at DOURGES on 20th October in an important house in the village, and 1 not located. DOURGES was occupied on 16th Oct.

- (2) The minimum delays for the above are

<u>CAMBRAI</u>	15 & 16 days.
<u>DOUAI</u>	7 days
<u>EPENY</u>	15, 20, 28 & 34 days.
<u>ROISEL</u>	47 days
<u>GOUZEACOURT</u>	5 days
<u>DOURGES</u>	4 days

- (3) The following points appear noteworthy regarding Delay Action Mines, more especially on railways

(1) The subsidence of the ground at vertical shafts after rain. Water may be poured on suspected points. Permanent way men should immediately report any subsidence for investigation. Railways should be again examined by Tunnellers after heavy rain.

(2) All surface demolition craters, shell holes and hollows should be probed to see if the ground is soft underneath.

(3) Now that the devastated area has been left behind, a blown house should be regarded with suspicion.

(4) The railway demolitions appear to be generally grouped in important localities with fuses of different delays. Such localities (junctions, bridges, level crossings, etc). require particular attention especially if a mine has already exploded or been found in the vicinity.

(5) From a transportation point of view the Railways are the more

334

APPENDIX No 7

2

Page 2.

are the more

important points. ~~xxxx~~ A crater will delay traffic for hours and a bridge for days.

(6) The possible use of a compass in locating mines charged with shells, even in spite of the rails. This requires experiment.

(7) The importance of a detailed examination of the permanent way before any repair gang get to work on it. Slight indications such as mud on sleepers etc, may be then found.

4. Please arrange to report at once any mines which explode or are removed giving details of charge, method of placing same, locality and any feature of interest. A list of those found to date to be sent.

Any tips or indications by which delay action mines may be located should be immediately reported to this Office for circulation.

G.H.Q.
26/10/18.

(Sd) B.W.Y. DANFORD, Lieut. Col.
Inspector of Mines

NOTE. Information since received shows that the Northern Mines were composed principally of shells. At CAMBRAI they each consisted of 6 - 5.9" T.M. shells with 2 delay action fuses in each charge. at DENAIN 4 consisted of 1 - 11" T.M. shell and 1 of 1 - 11" T.M. shell, 1 - 5.9" T.M. shell and 1 60lb tin of Perditite with 1 delayed action fuse in each charge.

The 7 Mines N.W. of BPENY were spaced at distances varying from 35 to 66 yards.

APPENDIX No 7

Controller of Mines
4th Army.

7
Inspector of Mines
No. 4181

3

The following extract from a report of Controller of Mines, 5th Army, on an explosion of 2 Road Mines of the type described in plate 5 Fig.1 of E.in C. Fieldwork Notes No.59 whilst being dismantled, which resulted in 3 Sappers being killed, is forwarded for information

It has been difficult to ascertain definitely the exact cause of the explosion in both cases as no-one in the vicinity was left alive to tell the tale, and after these accidents had occurred orders were given for the Road Mines not to be opened up and rendered harmless but to be carefully removed, and destroyed with explosives. The O.C., 250th Tunnelling Coy., informs me that he considers both accidents were due to the safety pin retaining the striker of Fuse Lighter being very delicately set (on the mouse trap principal) and greased, with the result that the vibrations caused by the withdrawal of the sliding block caused the safety pin to be completely withdrawn. All evidence obtainable points to this being the case and not to the introduction of some new device on the Booby Trap principal, which, on being dismantled explodes. Safety pins of German Fuse Lighters of the nature used in this Type of Road Mines have been found elsewhere well greased so that a very slight shock will set them off. As however, the examination of Road Mines of this type is manifestly a very dangerous operation, orders have been issued to all Companies to remove and destroy them on discovery and not to dismantle them; consequently it has not been possible to obtain absolutely conclusive evidence of the cause of the explosion in the above mentioned case.

(Sd) D.W.Y.DANFORD, Lieut. Col.

Inspector of Mines

G.H.Q.,
26/10/18.

APPENDIX N^o 75

CF/AG. Copy.

GENERAL HEADQUARTERS.
British Armies in France.

30th. October. 1918.

Dear Buckland;

I have received many reports of the fine work done by the Engineers in recent Bridging operations - especially in those operations involving a high degree of pluck and ingenuity in the face of the enemy.

I am sure the whole Corps at Home and Abroad and their opposite numbers in the Dominions when they hear of the way in which the obstacles were so gallantly overcome - will be filled with pride - our congratulations are due too to all those whose foresight and initiative have contributed so much to success.

Our thanks and congratulations are also due to the Tunnellers for their conspicuous success and gallantry in the searching out and removal of enemy mines - always a risky operation. Over half a million pounds of enemy explosives have been removed to date.

Yours sincerely;

sd. G. M. HEATH.

CE. Fourth Army. E. / 158 / 13.Chief Engineer,
Australian Corps.

For information.

A.H.Q. 31/10/18.

sd. A. E. W. Wedd. Major. RE.
Staff Officer to Chief Engineer. 4th. Army.

354

1st AUSTRALIAN TUNNELLING COMPANY.	
No.	8/355
Date.	2.11.18

Handwritten signature/initials

CONTROLLER OF MINES, FOURTH ARMY.	
No.	23/306
Date.	2.11.18.

Chief Engineer.,
Fourth Army (Adv.)

I met the C. of S. Fifth Army yesterday, and had an opportunity of discussing the arrangements adopted in the Fifth Army, for searching for traps, Delayed charges, Land mines, etc.

Owing to the deliberate nature of the enemy retirement opposite the Fifth Army, demolitions have been carried out extensively, and Delayed Action Mines, Traps and Land Mines have been laid systematically.

There are indications that the enemy contemplates a further retirement opposite this Army, and it is probable that his arrangements for Demolitions etc will be more complete than has been the case hitherto.

Information.

As in this Army, it was found that formations did not report Delayed Mines, Traps, and Land Mines, consequently, at first, the seriousness of the enemy traps was not fully realized.

This was particularly noticeable in the case of the Transportation units, which usually work in a water-tight compartment, and maintain secrecy about their arrangements.

In the Fifth Army, all (i) Delayed Mines
(ii) Traps
(iii) Land Mines
which go off, or are discovered and removed; are reported to A.S.G. and a Map kept showing the positions.

To date Tunnelling Companies have found and removed 19 Delayed Mines, and innumerable other charges.

Search.

This appears to have been undertaken by Corps from the beginning, but, at first, the tendency was to delegate one Tunnelling Company in each Corps to undertake all search for charges in the Corps Area.

This was found to be unsatisfactory, as the area was too great for the C.C. Tunnelling company to control, and the tendency was for Sections to be attached to Divisions.

The arrangement now, is for each Tunnelling Company to be responsible for a fixed area (as far as possible conforming to Divisional or Brigade boundaries).

The C.C. Company can employ his numerous Officers and N.C.Os and a proportion of mappers to the best advantage searching his area, the remainder being employed on roads behind the Divisional Pioneers, or on such other work as may be allotted to them.

Whenever a lull in the advance occurs, the C.C. Tunnelling Coy can re-search his area, and deliberately investigate suspected areas and important bridges, crossings, etc.

During the advance, at first, it was found that the party of Tunnellers following the infantry would stop to investigate a suspected mine field. They would warn all transport not to go further
owing/

APPENDIX N°7

7
Com

354

owing to no investigation having taken place forward.

Frequently this warning was ignored, and casualties resulted.

The arrangement now is as follows :-

1. The advanced party investigates only and does not remove charges. At all suspected places a sentry is left to warn transport to avoid that place.
2. A second party follows up the first and removes all charges and at the same time makes a more deliberate investigation.

Evidence accumulates proving that the search in this Army has overlapped in many cases, and that in other cases important mine-fields have been left.

The method which has proved satisfactory in the Fifth Army is similar to that suggested in my 26/272 d/31.10.18.

In addition to these suggestions, I would further advise that arrangements be made to collect all good explosives in a few dugouts or magazines, and that tank mines etc be destroyed.

Hitherto there has been a tendency to pile Tank Mines along the side of the road, to fence mine fields, and to leave explosives lying about, where they are a danger to troops in the vicinity.

Lieut.-Colonel R.E.
Conroller of Mines,
FOURTH ARMY.

Copy to O.C. 1st Aust Tm Co for
information.

APPENDIX N^o7.

REPORT ON EXAMINATION OF GERMAN AMMUNITION DUMP

5

354

AT ANNAPPEE. (P.10.b.9.5.Sheet 36)

3rd and 4th November 1918.

The dump consists of separate dugouts placed at 15 yard intervals, and contains, in all, some 5,000 shells of all calibres in addition to bombs, grenades and other explosives.

102 dugouts were examined.

Of these, 77 were empty or had been partially destroyed by fire or perdit charges, and 25 contained explosives, and many of these also showed signs of attempted demolition by fire, generally ineffective.

All shells were removed from dugouts and their fuzes examined, with the result that 4 1917 pattern German delay action fuzes were discovered.

<u>No. of Fuzes.</u>	<u>No. of Shells in Dump.</u>	<u>Position of Fuze.</u>	<u>How disposed of.</u>
1	300	Fuze screwed into 21 cm. shell.	Unscrewed fuze and removed detonator.
1	300	Loose fuze hidden in a pile of shells.	Removed fuze and took out detonator.
1	-	Loose fuze lying on a pile of shells. Fuze had exploded without detonating shells.	
1	400	Fuze screwed into 21 cm. shell.	Unscrewed fuze and blew off detonator (gains being too tightly screwed on to remove)

Notes on Fuze. The fuze is identical with the one described in XI Corps G.S. 51/59 of 14.10.18, being an accurate imitation of the German Gr.2.04, Nowr. Fuze.

Methods of Recognising. The following points of difference were noticed in addition to those previously recorded :-

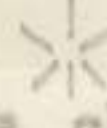
- (a) A small 6 pointed star thus  was stamped on the apex of each demolition fuze (see sketch). This was found to be a very useful outward indication.
- (b) The safety pin in the demolition fuze being a dummy, is immovable, whereas in the Gr.2.04 fuze it slides readily in and out.

The absence of punch marks was also found to be a reliable indication as in no case was a demolition fuze found to be punched into the shell, and it could always be easily removed by hand or with a spanner.

.....

APPENDIX N°7

4

Fourth Army "I" No. I.G./84/1.
IX Corps "I"/I.G.631.

C.E. IX Corps/E.3066/33.

354

C.E. IX Corps.

The following letter, received from Intelligence, Fourth Army, is forwarded for your information:-

"It is reported that a P.O.W. has stated that the following method is adopted by the enemy in working delay action mines.

A crater is blown by the enemy previous to retirement, and a delay action mine is buried at the bottom of the crater and carefully covered over. The crater is then filled in by our troops, and, at the expiration of the period, the mine explodes.

Further enquiries are being made, and any fresh information will be forwarded to you as quickly as possible."

(sd) G.F. GARNEGIE,
Capt.
for Major, G.S.,
IX Corps.

IX Corps Intelligence,
9th. November, 1918.

C.R.E., IX Corps Troops.

For information.

(Sgd) J.P. Tosh

Captain, R.E.,
for Chief Engineer, IX Corps.

9:11:18.



ESG
1/11



O.C. 1st Aust. Tunn. Coy A.E.

All units filling in craters will carefully search bottom first by probing, etc

10-11-18.

Wm...
Adj. for Capt. R.E. IX Corps Troops

APPENDIX N°7

Controller of Mines
Fifth Army. N.37/
I. of M. 3943.

10

Inspector of Mines.

A railway line on this Army Front was carefully examined for delay action mines before the recent heavy rains ~~xxxxxxx~~ ~~xxxxx~~ and nothing discovered. After the heavy rains of Nov. 6th and 7th, the line was re-examined. 9 delay action mines were removed, all of which were discovered owing to a subsidence having occurred over the spot where mines were buried after the heavy rain.

The importance of re-examining railway lines and other suspected localities for delay action mines, whenever the situation permits is therefore emphasised.

(Sd) J.C.HYLAND, Lieut.Col. R.E.
Controller of Mines
Fifth Army.

9/11/18.

APPENDIX N^o7

POINTS OF INTEREST IN CONNECTION WITH DELAY ACTION CHARGES.

WHICH PROVED USEFUL IN LOCATING THESE CHARGES.

TYPE OF MINES. Chambers placed between the tracks in double track lines.
Size on plan approximately 4' X 2' and 6' to 8' deep.
Charges: 5.9 shells placed horizontally.

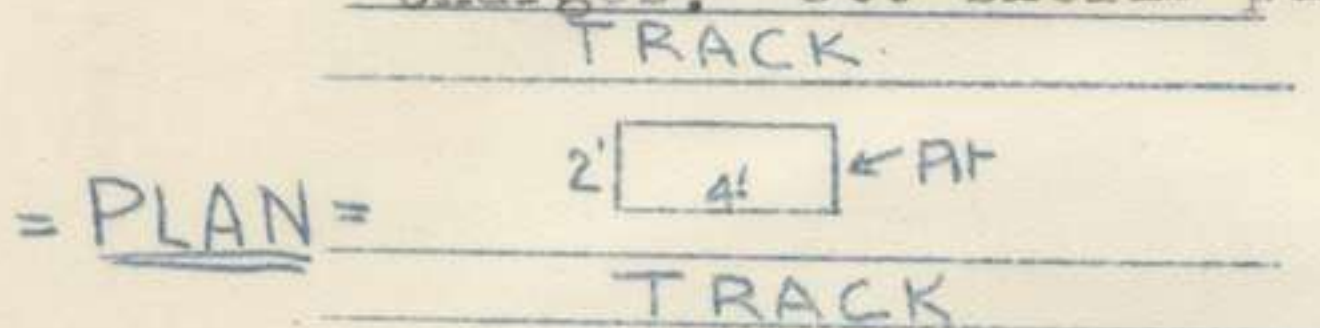

Chambers placed between the lines in single track lines.
Size on plan approximately 4' X 4' and 6' to 8' deep. Charges found in 98 lb. and 48 lb. metal boxes. Section of pit similar to No. 1 above.
Chambers placed at right angles to the steel and parallel to ties. Size on plan 4' by 2'. Similar section to No 1. above.
Chambers against brick bridge abutments.

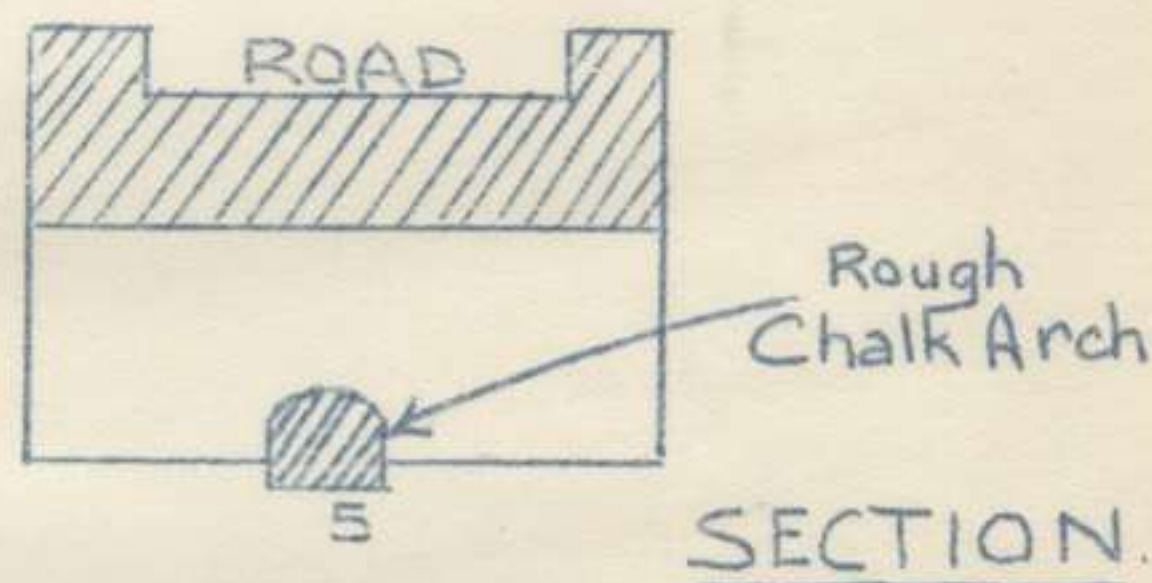
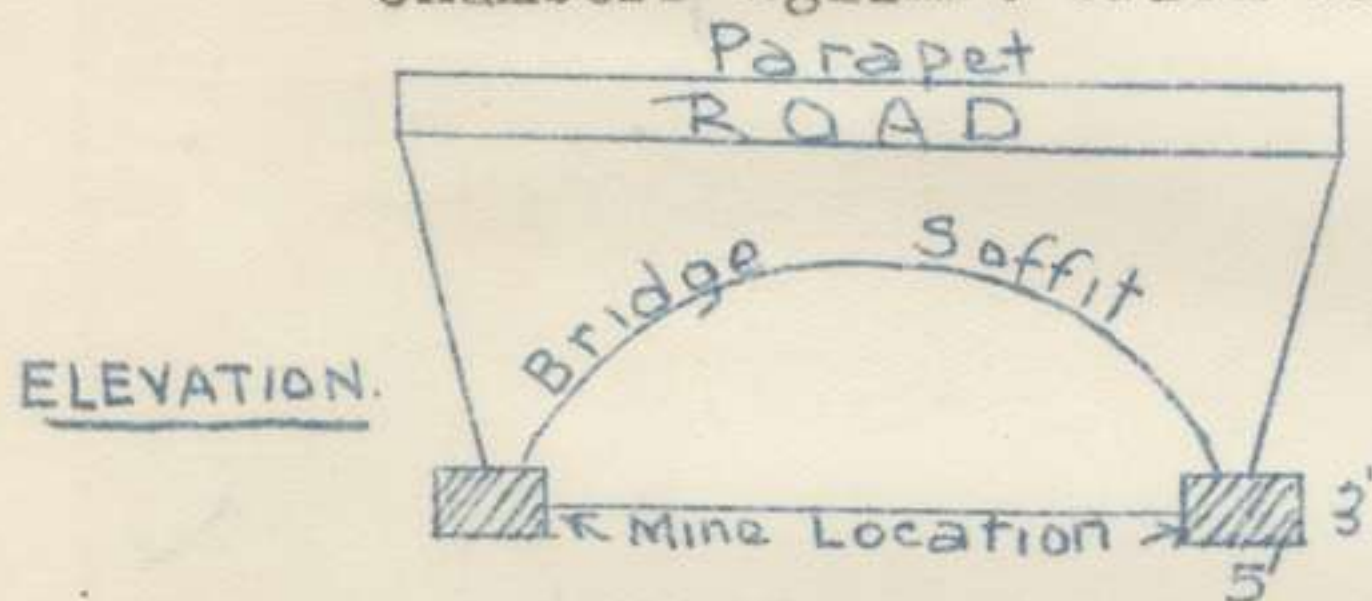

WHERE TO LOOK FOR CHARGES.

Permanent way.
Slopes of an embankment for galleries.
Huts.
Shelters.
Cubby holes.
Culverts. Examine roofs, sides and bottoms, for indication of bricks removed.
Station buildings and houses in close proximity to lines.
Examine cellars. Galleries might be driven from cellars
Bridges where destroyed. The abutments and foundations in close proximity. When bridge is demolished, examine for a mine placed to destroy any new bridge erected.
Craters are not excepted as denoting no further charges.

HOW TO LOOK FOR MINES.

Track should be examined by walking both ways as signs are often missed going one way which are picked up going back. Officers and men must be encouraged not to get disheartened by opening up a number of pits and finding nothing. The whole reconnaissance party should make up its mind there are mines there and they must be found. All examined pits should always be marked.

Surface disturbance.

Note any disturbance of ballast on permanent way, traces of small heaps of clay and chalk left lying (Surplus from pits after refilling. Made ground ascertained by probing.

Depression. on track approximately rectangular in shape marked on edges by a crack and this is accentuated ~~byxxxxxxk~~ after rain - indicative of made ground.

TRACES of spoil. On ties and on steel, especially clay, loam, or chalk on top of ballast. Softness of ground can be observed by use of sharp metal pointer thrust through between lumps of ballast.

Traces of foreign matter. in ground below ballast - for example, - ballast in small lumps under the soil & twigs - decayed grass - and leave, etc. - portions of boxes, S.A. ammunition etc.

Surface subsidence. A subsidence of ground especially after rain.

Plant growth. The continuous growth of weeds on tracks usually assign that no pits have been dug - rain encourages a quick growth of weeds, therefore this sign should be carefully investigated. Grain and oats growing in ballast not seen except at pits, absence of grass growing in ballast, most of the space between tracks is overgrown with grass if normal.

Indication of charges. Wicker shell baskets - plain iron nose caps - spiral springs from inside the nose of T.M. shells - empty boxes of explosives.

Position of charges. Often 50 - 70 yards on either side of a bridge (over or under a track) which has been destroyed. 60% in embankments, 30% on level, 10% in cuttings. Station yard containing a network of sidings contain more charges than other parts of line. Shafts on track sometimes found at regular intervals

(a) 60 yards apart

(b) 130 yards apart

Majority of pits found charged were near switches.

Method of testing. Ballast removed and ground probed - if suspicious excavate.

Tracks newly repaired and re-ballasted. No indications. Ballast has to be cleared and ground probed - therefore essential that reconnaissance takes place before track is relaid.

Tricks in charging. Pits are dug to 8', left open and uncharged, to give the impression that owing to lack of time no charges had been put in - probe bottom. Other pits have been dug, charged, and carefully filled - the dirt remaining appearing to be from the open pits.

Inspector of Mines

No. 3143

12/11/18.

GERMAN DELAY ACTION FUZE

FOR 7.6 cm. MINENWERFER SHELL.

— FULL SIZE —

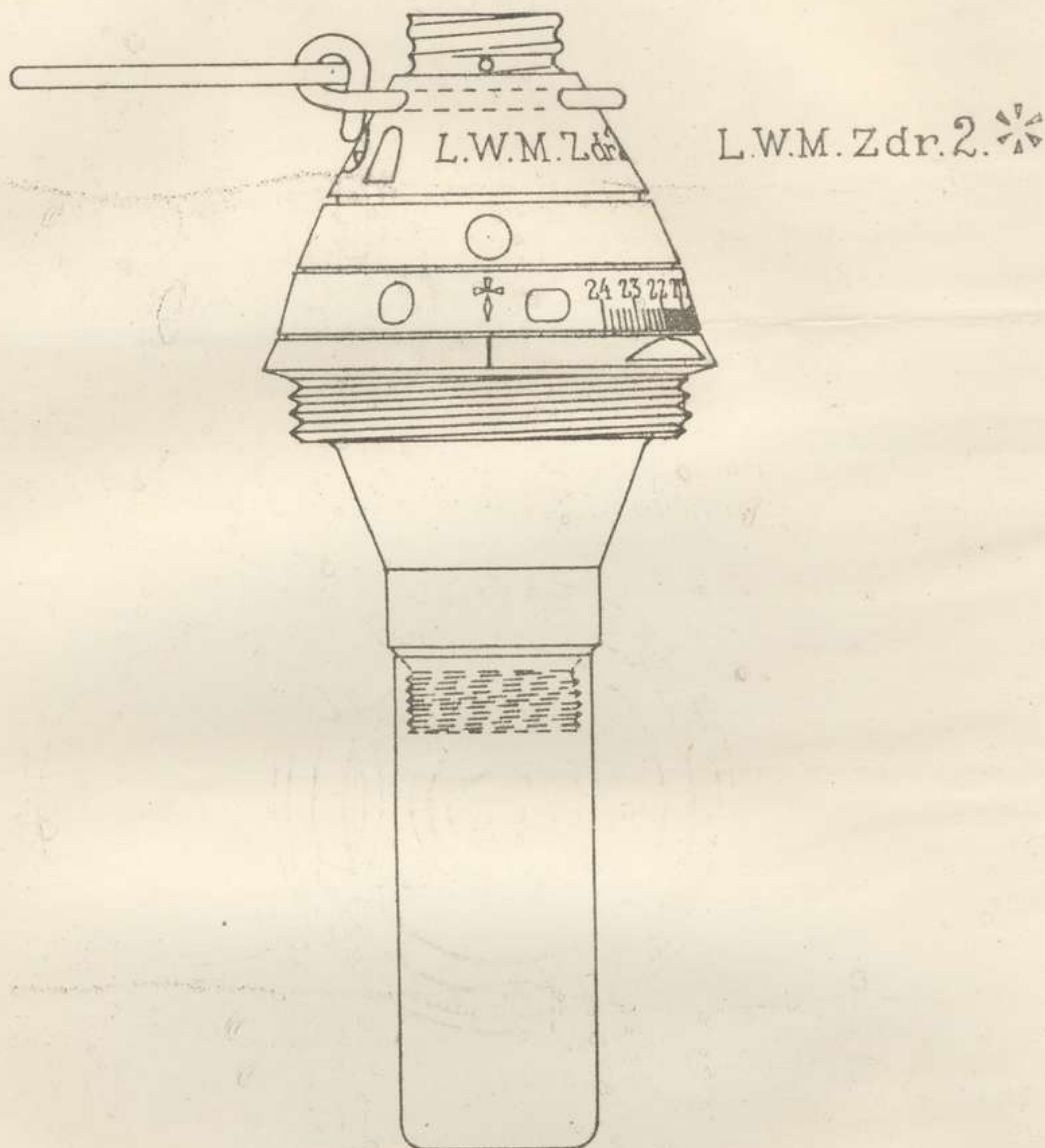

ELEVATION

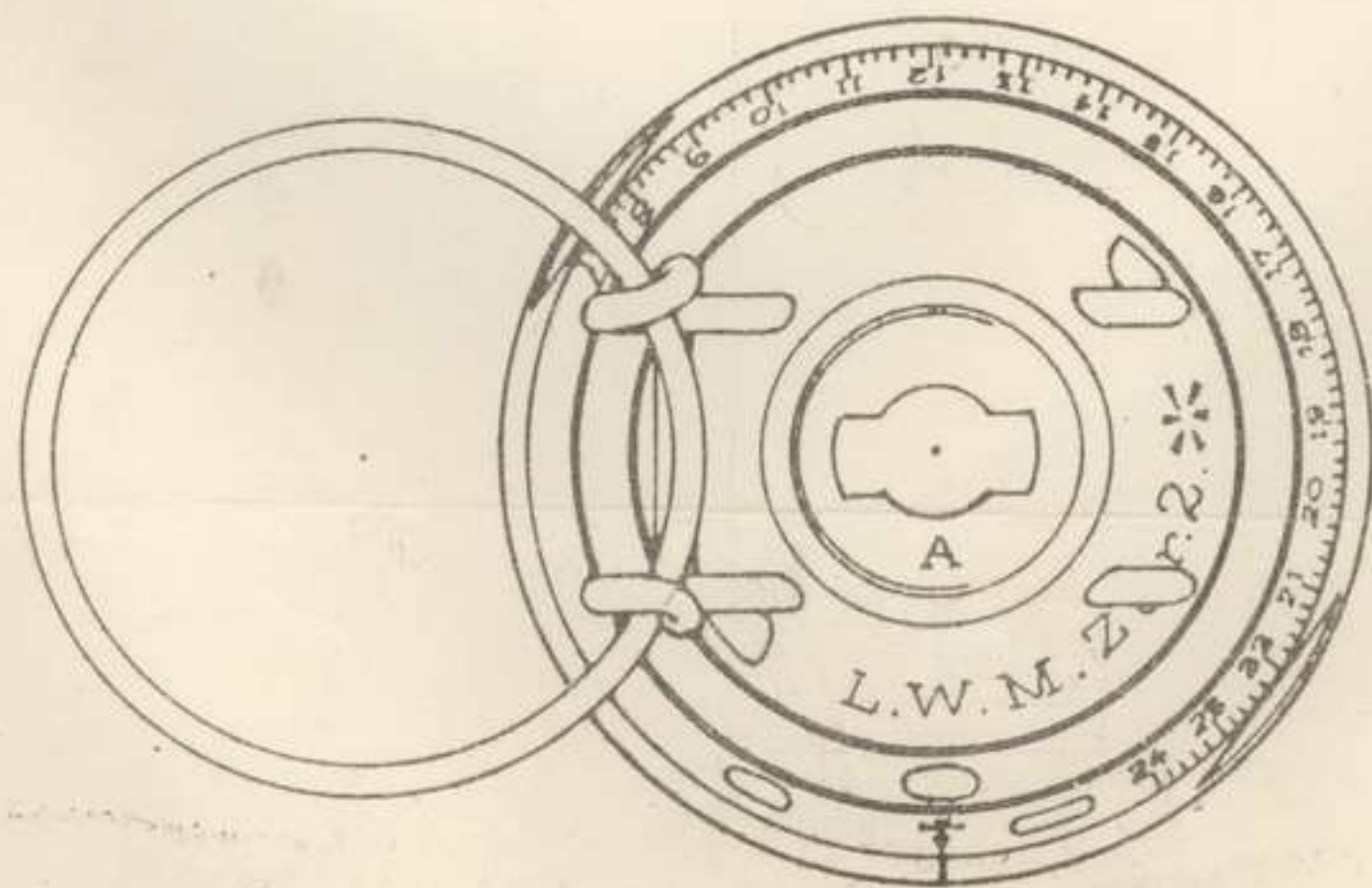

PLAN

GERMAN TRAPS AND LAND MINES.—IV.

From a captured German Document (undated).

354

A.—TANK MINE FIELD.

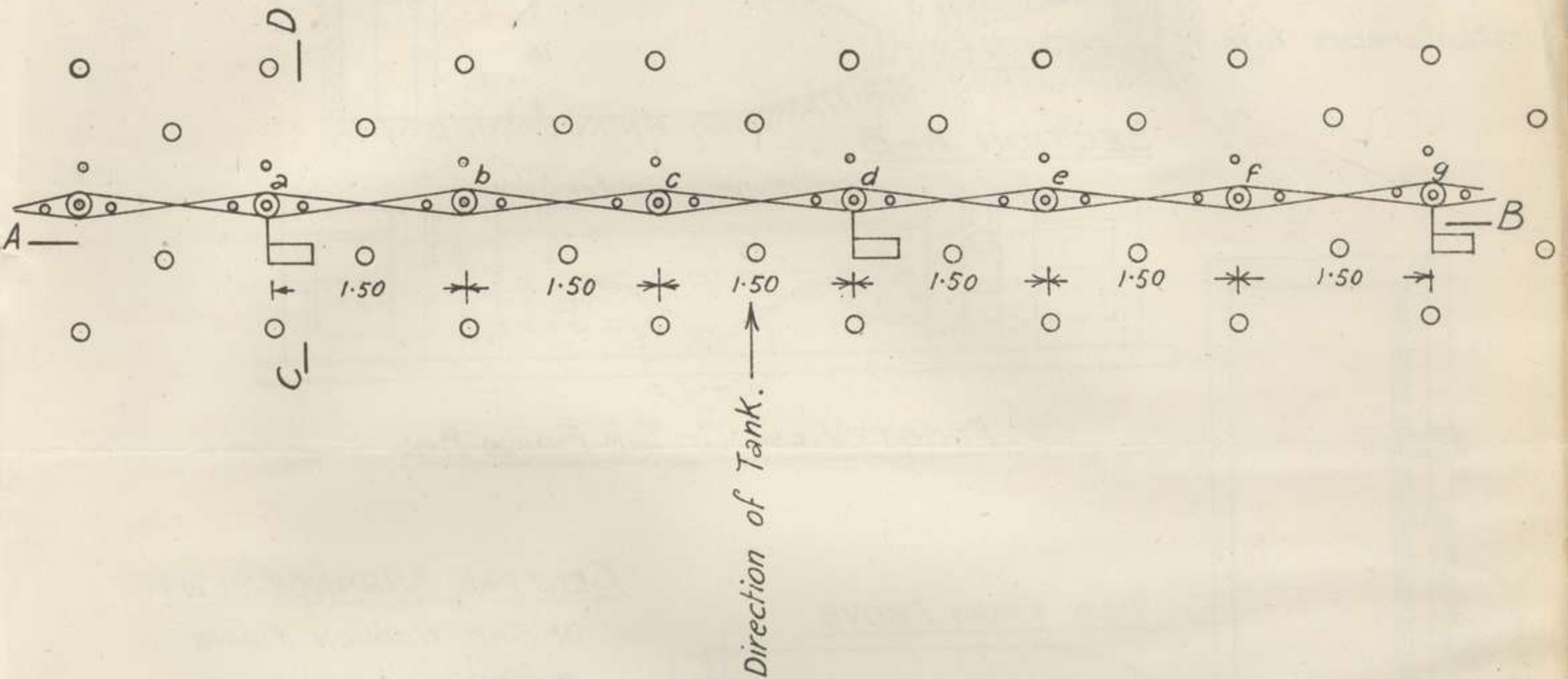

SECTION A-B

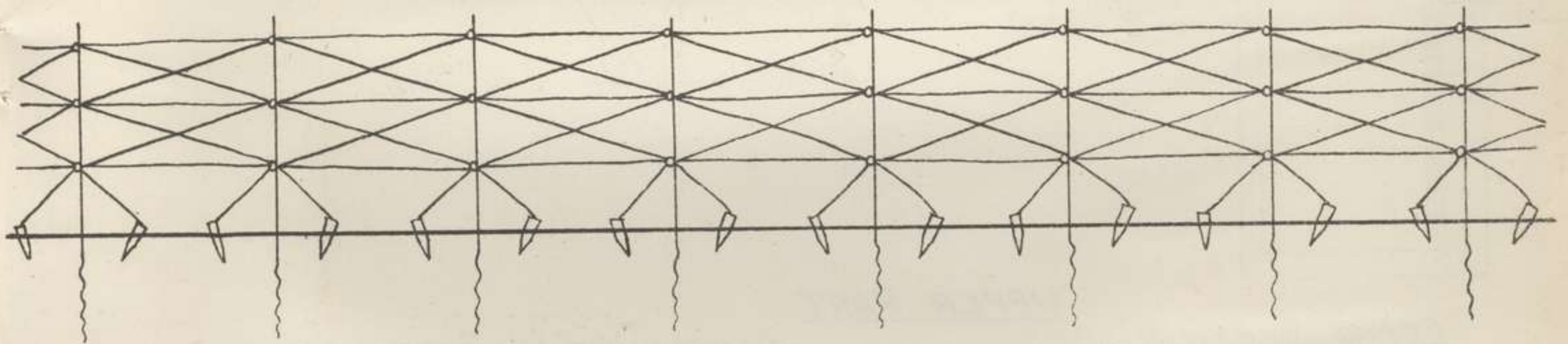

SCREW PICKET TANK MINE.

LEGEND

- ⊙ Mine obstacle.
- Protective obstacle.
- Anchor pickets.

SECTION C-D

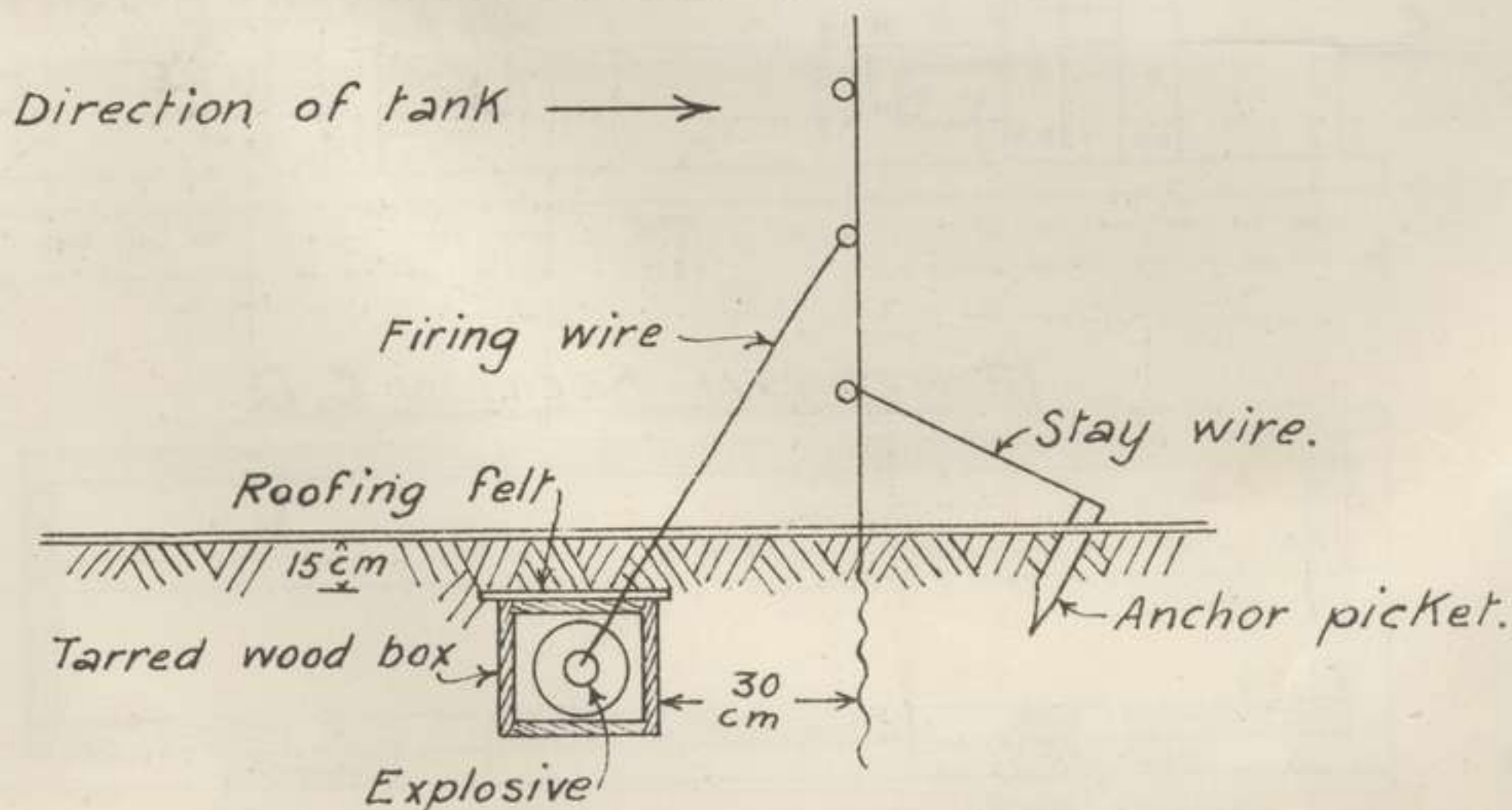

[P.T.O.]

354

B.—CONSTRUCTION OF A TANK TRAP.

"ZINK" TREAD MINE.

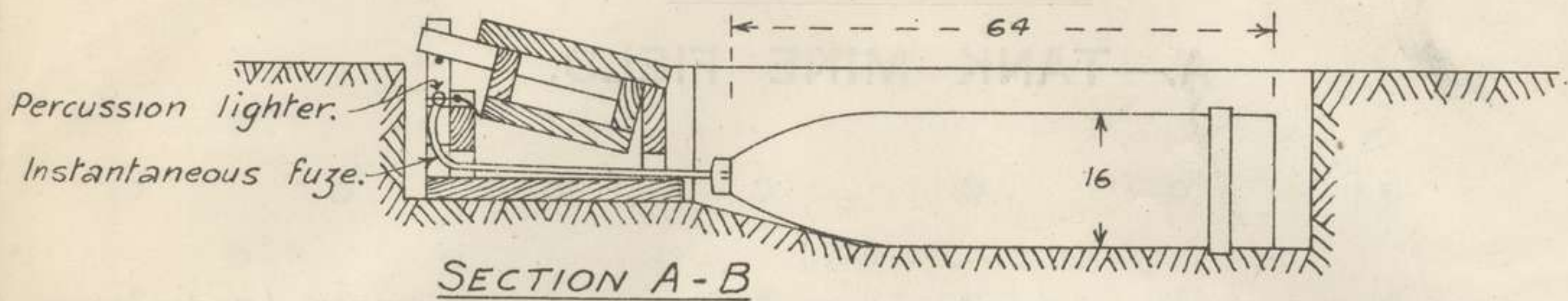

SECTION A-B

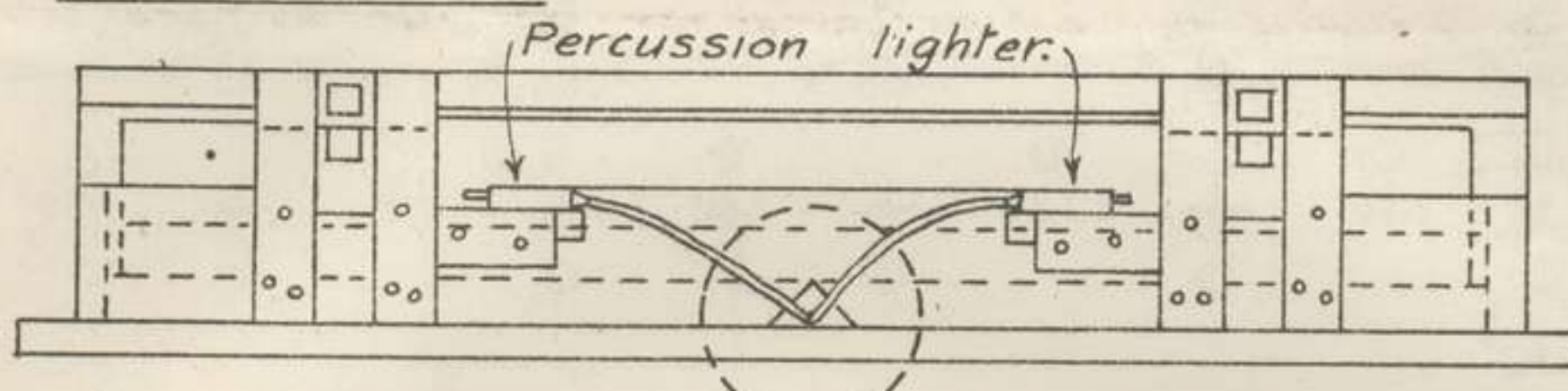

FRONT VIEW OF THE FIRING BOX

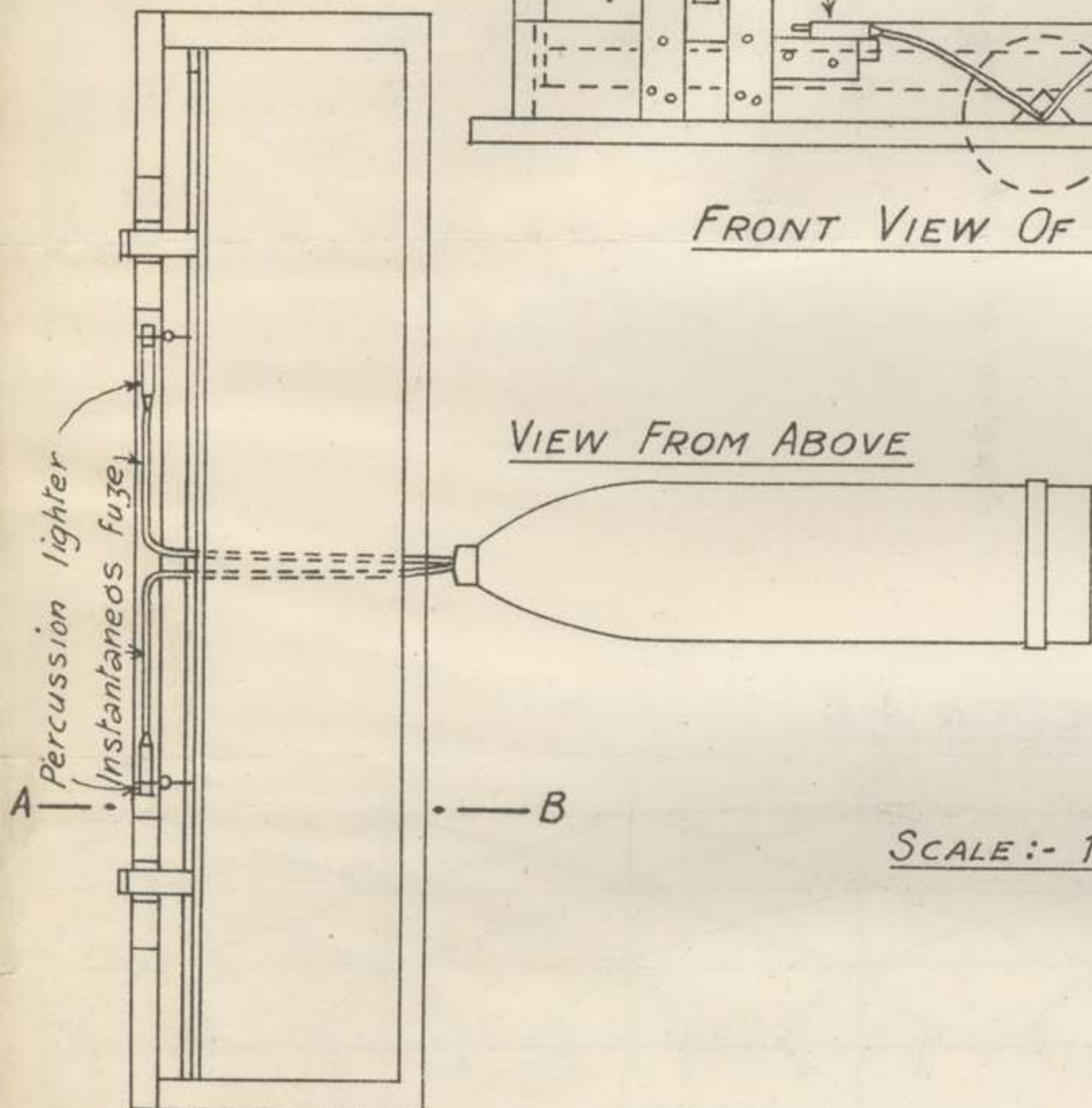

GENERAL ARRANGEMENT OF THE WOODEN FIRING BOX CONNECTED TO A MEDIUM T.M. BOMB.

SCALE :- 1:10

CROSS SECTION

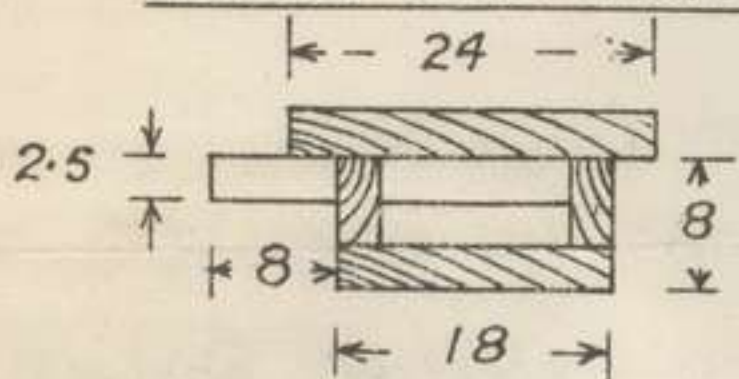

UPPER PART.

LONGITUDINAL SECTION

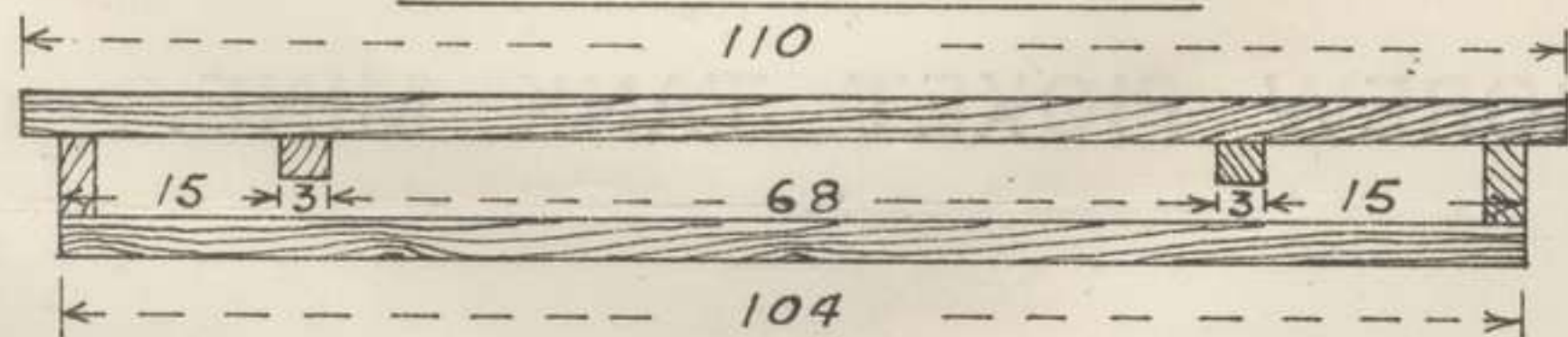

UNDER PART

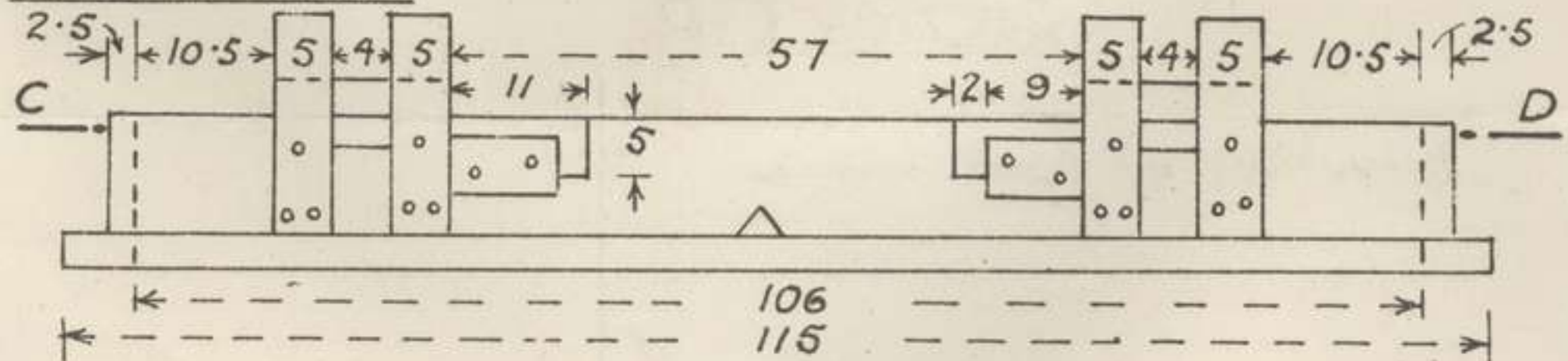
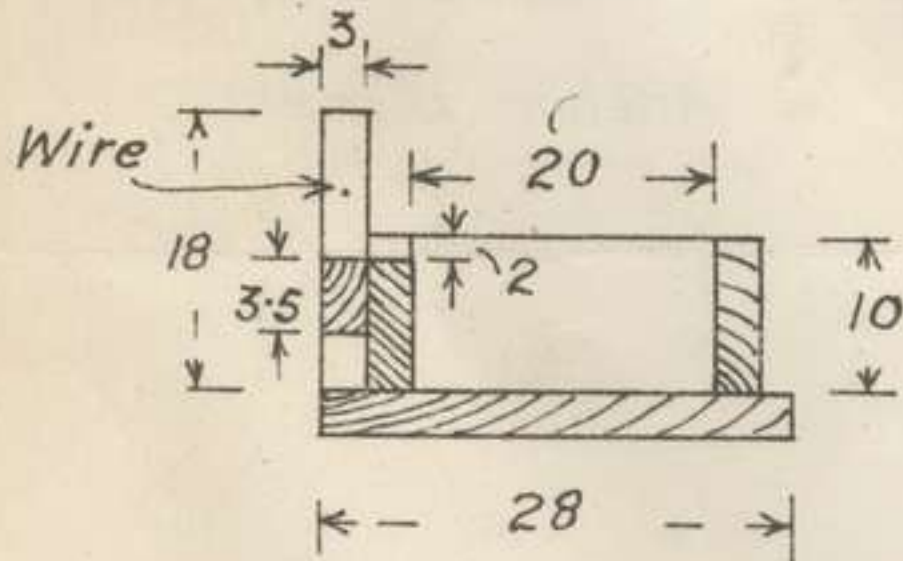

HORIZONTAL SECTION C.D.

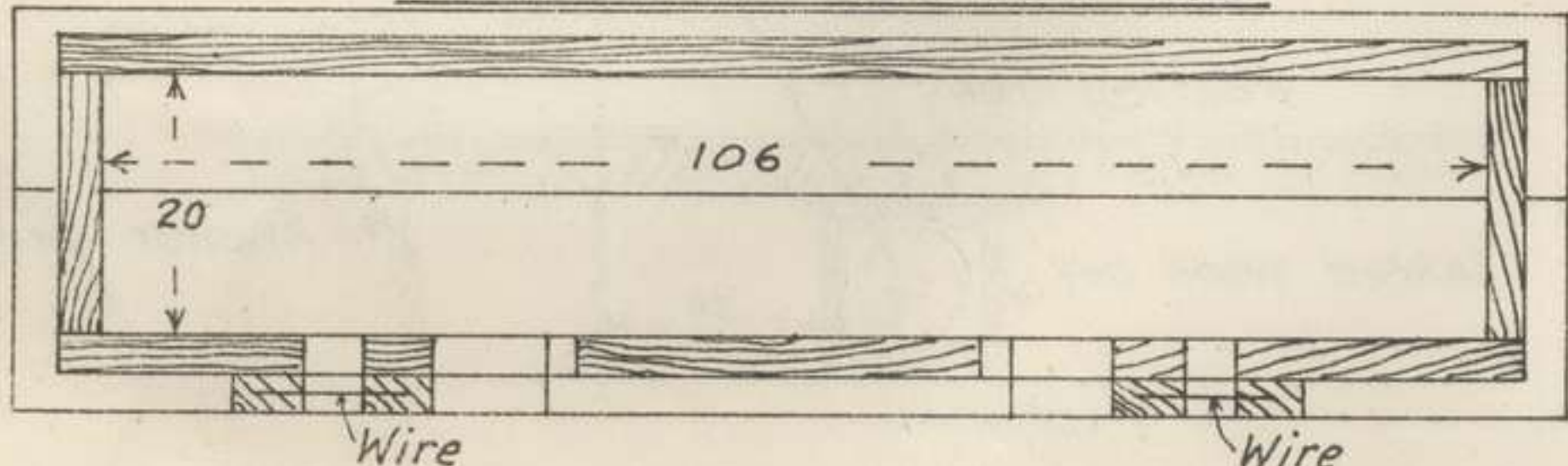

SCALE: 1:10

All dimensions in C.M.

Plank 10" Wide

General Staff (Intelligence),
General Headquarters,
10th November, 1918.

Printing Company, R.E.—W.O.B./2380.

THE 1917 GERMAN LONG DELAY ACTION FUZE FOR DEMOLITION PURPOSES.

(From German Documents.)



This fuze, screwed into an ordinary H.E. shell, is intended for destroying guns, battery positions, dug-outs, etc., or to blow up ammunition dumps abandoned to the enemy.

Description.—The mechanism is the same as that of the "German Automatic Detonating Device," described in Ia/81592 of the 5th April, 1917, that is, it depends on the action of a corrosive liquid eating through a wire. The fuze contains a detonator and an exploder charge.

It differs in appearance from the "Device," which was about 6 inches long and 1 inch in diameter, with a head $1\frac{3}{4}$ inches in diameter, and was painted black, in being exactly similar outside to the Gr. Z. 04 gun fuze ($8\frac{1}{2}$ inches long and over $1\frac{1}{2}$ inches in diameter, usually used with the 10-cm. gun, 15-cm. and 21-cm. howitzers, and not used in any field artillery shell); with the difference that **the gaine of the demolition fuze is painted red** and that of the gun fuze lacquered blue.

Means of recognition.—The fuze, when in a shell, being marked like the gun fuze Gr. Z. 04, cannot, as the gaine is concealed, be distinguished from an ordinary fuze.

All German shell, however, are issued fuzed. To prevent the fuze working loose, its lower edge is stabbed with a centre punch (usually in four or six places) into corresponding nicks in the top of the shell; or else, as in gas shell, the fuze is set in cement. The absence, therefore, of punch marks on the edge of the fuze, and of cement, may give an indication of the presence of a demolition fuze.

Removal.—The fuze can be screwed in by hand, and, therefore, may be removeable in the same manner, but can be removed by an adjustable spanner, as there are two flats on it.

If the fuze has been stabbed, a small hand drill will also be required.

Delay.—The fuze, by using different tubes of corrosive liquid, may be set for 1, 2, 24 or 72 hours delay.

Packing.—The fuzes are packed two together in a special box. On the label in red is:—

Lgz. Z. 17. Nicht verfeuern, nur für besondere Zwecke.

(1917 pattern long delay action fuzes. Not to be fired; only to be used for special purposes).

The liquids employed to ensure these "delays" are pale blue in colour and are issued in glass tubes about $\frac{3}{8}$ inch in diameter and 6 inches long. The tube is drawn out and sealed at each end and is marked either 1, 2, 24 or 72.

General Staff (Intelligence),
General Headquarters.
13th August, 1918.

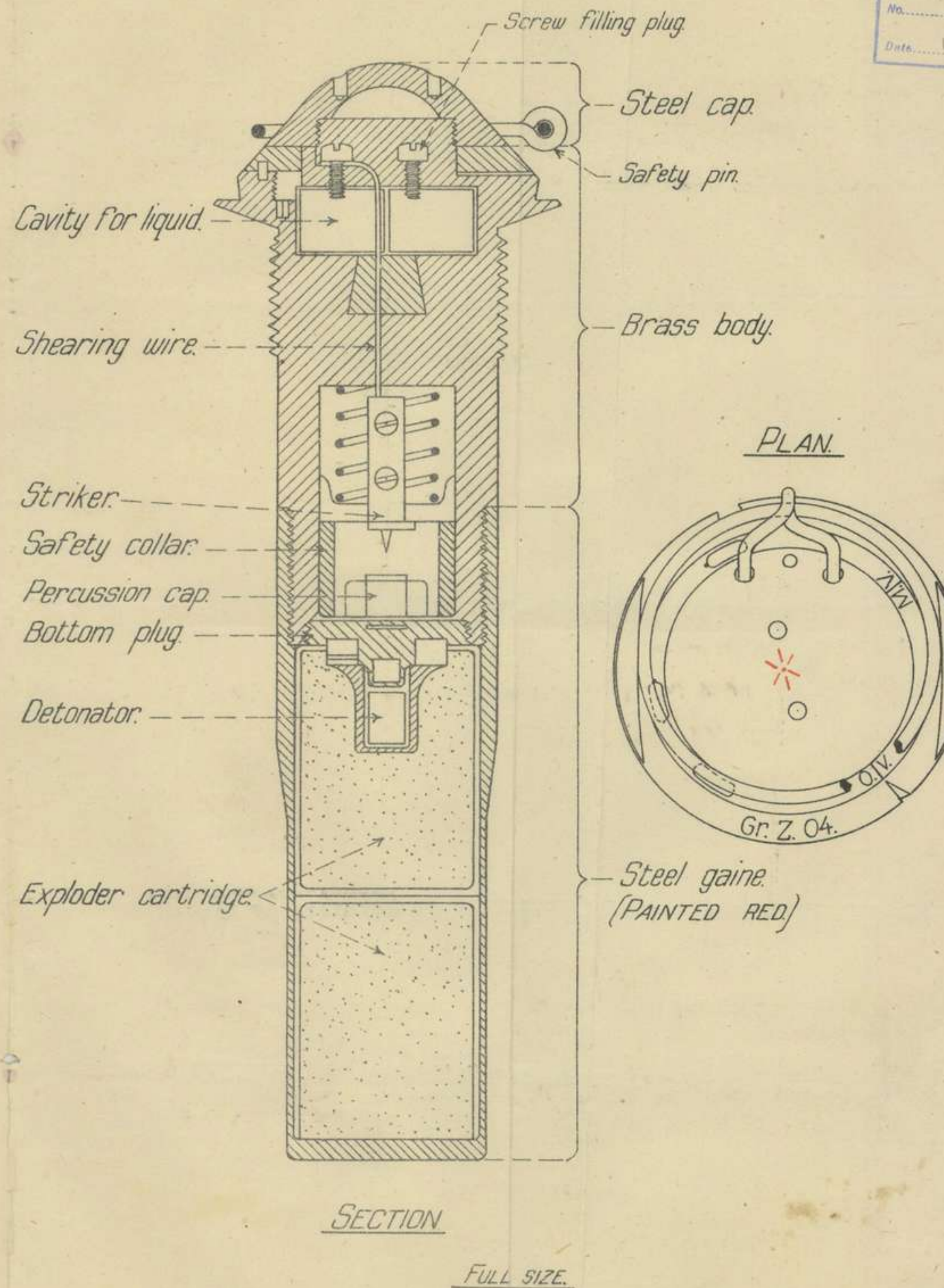

354

APPENDIX No 7

8

C.E. Fourth Army/E.159/3.

DELAYED ACTION MINES.

Chief Engineer, IX Corps.
 " " XIII "
 " " Aust."

In view of the present situation, the following risks will be taken for removal of Delayed Action Mines.

Owing to the very erratic timing of these fuzes, the same precautions should be taken whether a mine is overdue or otherwise, except in cases where a mine is not due to explode for over a month, when it will probably be safe to remove it.

A. Unimportant Roads and buildings adjoining them: Abandoned Railways.

D.A. Mines will not be removed from these unless ordered by C.E. of Corps, but the site will be fenced off and a notice posted warning people from approaching.

If necessary a deviation will be constructed.

B. Railways of secondary importance, or not yet operating. Road Bridges of secondary importance.

As soon as the site of a D.A. line has been definitely fixed, a hole 3 - 5 feet deep will be dug over the mine, and a charge of 3 - 4lb Gun Cotton, or other explosive fired at the bottom of the hole. If the mine does not then explode, it will probably be safe to handle the fuze with care, and the charge should be removed.

C. Railways and Road Bridges of Primary importance.

Every endeavour should be made to remove D.A. Mines: Great care must be exercised when handling the fuze.

The C. of M. will keep in touch with the Railway Operating Authorities with a view to being posted as to the importance of certain lines, etc.

(i). O.C., Tunnelling Coys. will keep in touch with :- The Railway Construction Authorities, so that when charges under heading "B" are being fired, preparations can be made beforehand to fill in the craters, or assemble material for building bridges:

(ii). Chief Engineers of Corps, so as to keep posted as to the importance of bridges, etc., and in order that arrangements can be made for diversions where necessary.

As far as possible, local unskilled labour, should be obtained from the Railway Authorities so as to economize skilled personnel.

R. H. ...

Major General.
C.E., Fourth Army.

A. H. Q.
13 FEB 18

COPIES TO C. OF M. ... ALL Tunnelling Coys.

354

APPENDIX 7

APPENDIX N°7

Controller of Mines
Fourth Army
28/470
16/11/18. 9

To. 1st Aust. Tunnelling Company A.E.

A new type of Booby Trap has been found by 182 Tunnelling Company. It consists of two bottles of some liquid, wrapped in corrugated paper wired to a special stick grenade.

The grenade has a red handle, and the spring for detonating it is covered with a screwed cap, and is very sensitive.

Presumably the spring is meant to be attached to some article, which on being moved detonates the bomb, and breaks the bottles, which probably contain some form of gas.

(Sd) J.E.HILL, Lieut.Col. R.E.
Controller of Mines
Fourth Army.

APPENDIX N°8

18

354

Lieut. Plummer,

Lorry herewith with Midday rations to transport
you and party to Busigny.

Report here without fail 14th inst.

1st AUSTRALIAN TUNNELLING COMPANY.
No. <u>S/80</u>
Date <u>14-10-18</u>

WJB

Captain, A.E.
For C.O. 1st Australian Tunn. Company, A.E.

O.C. No. 1 Section,

Two G.S. Wagons will report to you this forenoon.

Please move your section gear with this and
your own Horse Transport to Headquarters Busigny.

The Section will march, lorry hopping wherever

possible.

Report here by 17.00 14th inst.

Entrainment for Germany is eminent.

1st AUSTRALIAN TUNNELLING COMPANY.
No. <u>S/80</u>
Date <u>14-10-18</u>

WJB
Captain, A.E.
For C.O. 1st Australian Tunn. Company.

O.C. No. 3 Section

Two lorries are leaving here at 06.00 to report to
you to assist you to move section to Company Headquarters Busigny.
24 hours emergency rations accompany lorries.
Make the trip in one day if possible, lorry hopping
wherever possible.

We may have to entrain for Germany at short
notice. Don't worry about rations from Boulogne unless you can draw
them in the morning before other two lorries arrive.

We will draw them the next day if we want them.

1st AUSTRALIAN TUNNELLING COMPANY.
No. <u>S/80</u>
Date <u>14-10-18.</u>

WJB

Captain, A.E.
For C.O. 1st Australian Tunnelling Company, A.E.

2/80

1001

2/80

Bill 45

2/80

8 M X I M F M H

13

APPENDIX N°8

19

354

O.C. No. 4 Section,

Box Car and five carpenters will be available for you at 07.00 3-11-18.

3 lorries & 5 G.S. Wagons will be available to move your special party at 12.00 to La VALLEE MULATRE.

3 G.S. Wagons will be also available, and will be despatched with guide to La VALLEE MULATRE at 07.30 to report to O.C. 23rd Company R.E., 200 yards over Railway Line on right (W.19.b.8.0)

1st AUSTRALIAN TUNNELLING COMPANY.	
No.	S/22
Date	2.11.18.

WAB

2-11-18.

For C.O. 1st Australian Tunnelling Company, AE.

Captain, AE.

Lieut. Hill

APPENDIX N°8.

You will move the whole of balance of No. 1 Section to Rejet de BEAULIEU tomorrow.

Lorry will be available at 0700.

Lieut. Thomsen will take Notice Boards for St Marbin Rivere and Canal Lock Bridge, and ~~take~~ place same in position if ready.

WAB

6-11-18.

For C.O. 1st Aust. Tunn. Company

Capt. AE.

APPENDIX 8

APPENDIX No 8

354
Captain Woodward

Please arrange to report to C.R.E. 1st. Division
VAUX ANDIGNY at 0930 2-11-18.

Make all arrangements for reconnaissance of proposed
tank bridge site; supply of material section move; and Nos. of
men required with C.R.E. direct.

Get all transport you can from C.R.E. direct, and
requisition on this Headquarters for balance.

(Signed) W. McBride Captain A.E.

2-11-18

For C.O. 1st. Australian Tunn. Company A.E.

APPENDIX N° 8

2

Captain Bowry

Keep your section in reserve for forthcoming Stunt
which may embrace bridging, and searching for mines, bridge
abutments, roads and dugouts.

(Signed) W. McBride Captain, AE

2-11-18
07.30

For C.O. 1st Australian Tunn. Company, AE

Captain Yates

Please arrange to report to C.R.E. 32nd. Division at BUSIGNY at 09.30 oclock 2-11-18.

Make all arrangements to conduct search for road mines and examine bridge abutments and dugouts in Divisional Sector of Advance direct with C.R.E.

Get all transport you can for section move from C.R.E. and requisition on this Headquarters for balance.

(Signed) W. McBride Captain AE

2-11-18

For C.O. 1st Australian Tunn. Company AE

07.30

O.C. No. 1 Section

You will detail Lieut. Thomson and 25 Other Ranks to report to Captain Woodward for work on canal bridge at 12.00 3-11-18.

They will carry picks and shovels for digging in.

Rations will be obtained from R.Q.M.S. to midnight 4/5th November and unexpired portion already issued.

(Signed) W. McBride Captain AE

2-11-18

For C.O. 1st. Australian Tunn. Company

O.C. No 2 Section

You will please detail loading party to BOHAIN Dump at ~~ASSIS TREN~~ to load material as shown on attached list.

2 G.S. Wagons at 08.30, 1 Lorry at 09.30 will be available to move your special party to St. Souplet. Please return lorry as soon as possible.

Rations to be obtained from R.Q.M.S. to be carried to M/n 4/5 November plus unexpired portion.

(Signed) W. McBride Captain AE

2-11-18

For C.O. 1st. Australian Tunn. Company AE

APPENDIX N°8

3

354

Captain Hinder.

Please arrange to report to C.R.E. 46th. Division
BOULAIN at 09.30 o'clock 2-11-18.

Make all arrangements to conduct search for road
mines and examine Bridge abutments and dugouts in Divisional
Section of Advanced direct with C.R.E.

Get all transport for section move you can from
C.R.E. and requisition on this Headquarters for balance.

(Signed) W. McBride Captain AE

For C.O. 1st Australian Tunn. Company, AE

2-11-18

07.30

APPENDIX N°8

4

1st AUSTRALIAN TUNNELLING COMPANY.	
No.	S/34
Date.	4.11.18

4-11-18

O.C. No. 1 Section,

C.R.E. 1Xth Corps Desires that 1 of the shafts
at D.S.C. examined by Lieut. Irving on 3-11-18 be emptied
entirely, if possible and result reported.

Lieut. Irving and 1 squad from No. 2 Section
will carry out this work.

No. 2 Section will detail this squad to report
to Lieut. Irving at 09.00 5th inst.

of 10 CR.

Copy to No. 2 Section

WMB

Capt. AE.
For C.O. 1st Aust. Tunn. Company, AE.

354

APPENDIX 8

APPENDIX N° 8

25

COPY . .

Chief Engineer,
1Xth Corps.

In the Railway Cutting N of BOHAIN (at about D.3.c) there are a number of small shafts sunk (Before the war) to a depth of some 20 - 30 feet, evidently for the purpose of draining the cutting.

Some of these have been blown in at the top, and it would appear advisable to open them up, to see if any delayed mines have been installed.

(SIGD) L.R.HILL Lieut.Col
Controller of Mines, 4th ARMY.

(2)

Captain Bowry.

Please make examination and report result.

3-11-18.

MS
For C.O. 1st Aust. Tunnelling Coy. AE
Capt. AE.

1st AUSTRALIAN, TUNNELLING COMPANY.	
No.	5/25
Dats.	3.11.18.

*P.S.A.
3/11*

1354

APPENDIX N°8

6

O.C. No. 1 Section

You will detail Lieut. Thomson and 25 Other Ranks to report to Captain Woodward for work on canal Bridge at 12.00 3-11-18.

They will carry picks and shovels for digging in.

Rations will be obtained from R.Q.M.S. to Midnig 2/5th November and unexpired portion already issued.

2-11-18.

Wod
For C.O. 1st Australian Tunnelling Company, A

Captain, AE

1st AUSTRALIAN TUNNELLING COMPANY.	
No.	<i>P/19</i>
Date	<i>2-11-18</i>

APPENDIX N°8

5

CDPY

O.C. 1st Australian Tunnelling Company, AE

Will you please send someone to have a look at BRANCOURT Church Tower which is reported mined. I'm sorry to have to call on you again but the Town Major of that place is very nervous about it, so would you kindly let him know the result of the investigation.

(Sgd TOSH Capt. RE.
For C.E. 1Xth Corps.

(2)

Captain Bowry.

above. Please make arrangements to carry out

WES

3-11-18.

Capt. AE.
For C.O. 1st Aust. Tunn. Company, AE.

1st AUSTRALIAN TUNNELLING COMPANY.	
No.	5/29
Date	3.11.18.

354

APPENDIX 8

APPENDIX N°8

Captain Bowry,

Immediately after lunch two lorries will be available to take 50 men with road scrapers and shovels to Canal Bridge at S.l.d. 3.4. for purpose of improving road on either side of bridge.

Lorries will remain with you to bring party back at dusk.

Please reconnoitre a camp site for your Advanced Headquarters with a view to shifting tomorrow.

meA

5-11-18.

Per C.O. 1st Australian Tunn. Company, AE.

Capt. AE.

1st AUSTRALIAN TUNNELLING COMPANY
<i>35</i> <i>5/11</i>
Date.....

APPENDIX

354

APPENDIX N^o 8.

COPY of WORK ORDER. No. R/33

20

The Road to the Bridge at Leck in S.l.d is a very bad narrow lane with very little metal. It starts beside the church in BEAULIEU and is NOT as shewn on 1/40,000 map. 1/20,000 is better

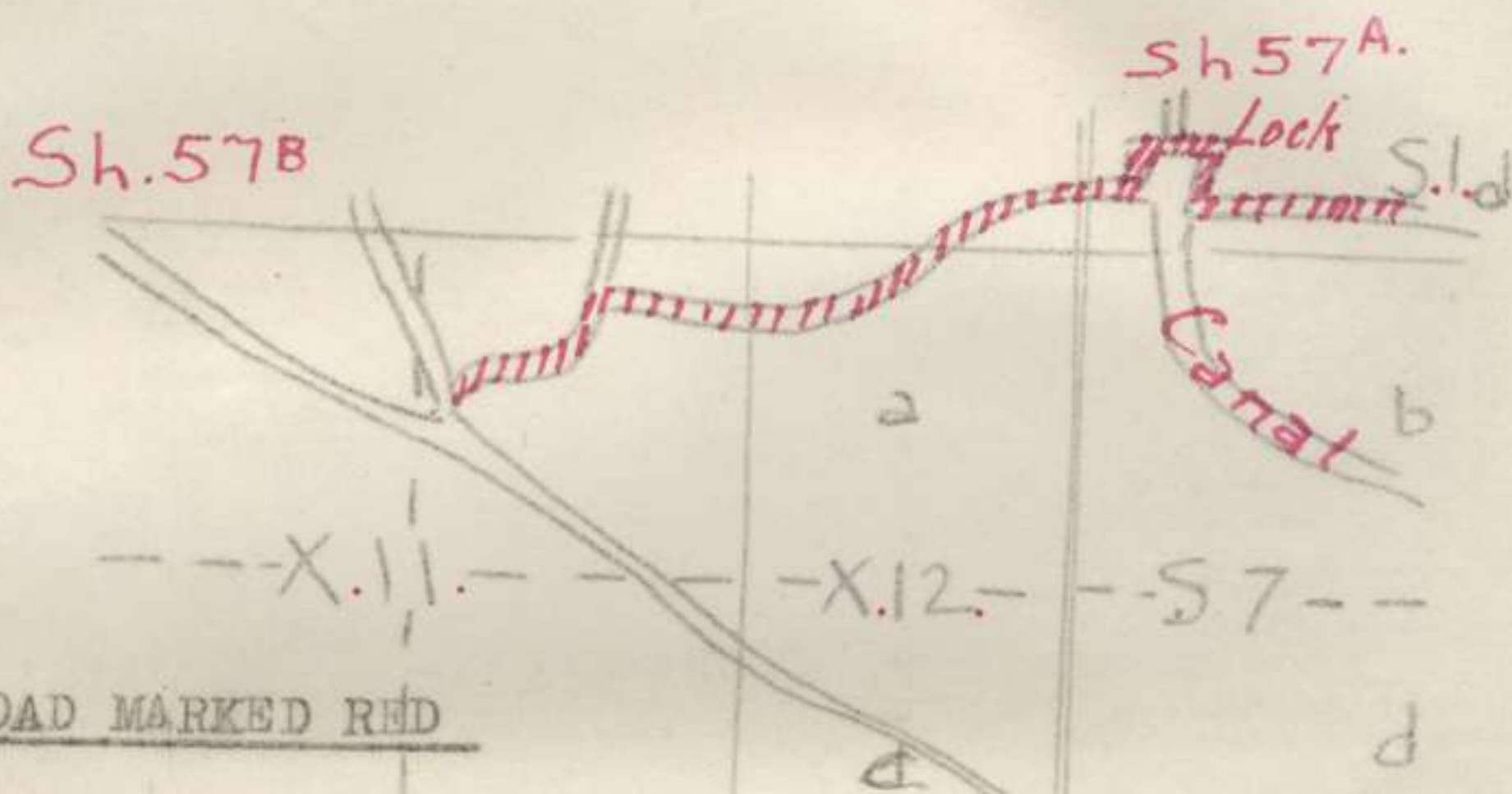

YOUR ROAD MARKED RED

Take cutting tools and use Brushwood under bricks in muddy places. Make some passing places and assist transport when it sticks. There are three horse transport bridges :- (1) M.31.d.4.4. (2) S.l.b.3.7 (3) S.l.d.2.8 (Wassigny Sheet). Patrol these and maintain them in passable order.

5-11-18.

(sigd) W.T. TRAILL Lieut. Col.
C.R.E. C.T.

O.C. No. 1 Section

Referende Tank Bridge Etc.

C.R.E. C.T. States :-

- (1) The Tank Bridge at S.l.d.3.4 requires a notice Board and direction boards from main roads at both ends of the "laice"
- (2) The Bridge over the stream West of the Lock does not appear very sound and the approaches to it are very bad.

These points should be seen to by your party detailed to work on the "Lane"

Please give effect to the above.

Notice boards are in course of preparation and will be forwarded as soon as possible.

WOB

6-11-18.

Captain, AE.
For C.O. 1st Australian Tunn Coy.

1st AUSTRALIAN TUNNELLING COMPANY.
No. <u>3/57</u>
Date <u>6-11-18</u>

WOB

O.C. No 1 Section

The C.R.E. desires that special attention be paid to the decks of all bridges over La Selle River and suggests that they be double decked.

Please arrange to carry this out and report completion.

WOB

Captain, AE.
For C.O. 1st Aust. Tunn. Coy. AE

2-11-18.

1st AUSTRALIAN TUNNELLING COMPANY.
No. <u>5/17</u>
Date <u>2-11-18</u>

APPENDIX 8

354

APPENDIX 8

APPENDIX N° 8

24

Captain Yates

Re shaftsin Bohain Railway Cutting.

Please arrange to empty and examine all shafts BOHAIN - BUSIGNY Railway Cutting, as per attached correspondence which please return with report.

Detail Sergts party of 12 O.R. inclusive to proceed by your own G.S. Wagen to report to Major Mitchell Australian Corps Headquarters as per copy of order attached.

This party will be rationed on Second day by lorry.

7-11-18

W. J. B.
Captain, A.E.
For C.O..1st Aust. Tunn. Coy. A.E./

354
COPY

(1)

C/R.E. 4th ARMY.

Sub Area Commandant CHUIGNOLLES reports suspected enemy mines at PROYART in house occupied by civilians. Other quarters have been allotted them pending investigation. For your attention please.

A.C.A. F.A. 4.

(2)

C.E.

----- Attached wire is forwarded to you please. Could you please arrange for the necessary work to be done.

(SIGD) W.F. CARR Capt. & Adj
C.R.E. A.T.

(3)

C.E. 1Xth Corps

Will you please have this investigated.

..... Major
For CE 4th
Army.

(4)

O.C. 1st Aust. Tunn. Company, AE.

Will you please investigate.

(SIGD) TOSH
For C.E. 1Xth Corps.

(5)

Captain Yates,
O.C. No. 2 Section.

Please attend to above and report result.

Box Car will be available at. 6

W.F.

7-11-18.

Captain, AE.
For C.O. 1st Aust. Tunn. Company, AE.

354

C.O. No. 1 Section

APPENDIX N° 8

26

Please arrange to patrol Bridges over La Selle River, and report condition daily.

med

10-11-18.

For C.O. 1st Australian Tunn. Company, A.E.
Captain, A.E.

1st AUSTRALIAN
TUNNELLING
COMPANY
165

SSA/11

APPENDIX N° 8.

27

1st AUSTRALIAN TUNNELLING COMPANY A.E.

Headquarters
11/11/18.

Lieut. H.D. Hill,
No. 1 Section.

You will remain at your present location until transport can be arranged for your removal.

In the meantime you can carry on filling in shell holes in the village street, and remove notice boards from bridge site, if this has not already been done.

You will be advised later when and where transport will report.

J. Sawyer
Lieut. A.E.

Adj. & Q.M. 1st Aust. Tunnelling Coy. A.E.

1st AUSTRALIAN
TUNNELLING
COMPANY.
No. *5/69*
Date *11.11.18.*

The transport reporting tomorrow for roadwork.

SSA/10/11

APPENDIX N°8

Captain Woodward,
O.C. No. 4 Section,

Suspected delay action mines on CHAULNES -
PERONNE Railway (Amiens Map)

- (1) 91 metres North of crossing - CHAULNES - MARCHEPOT Road
- (2) 118.3 metres South of crossing GENERMONT - MARCHEPOT Road.

Please investigate, remove if any and report.
Lorry will be available at 10 a.m.

Lieut Plummer plus other ranks with
picks and shovels will be detailed.

48 hours rations will be carried.

1st AUSTRALIAN TUNNELLING COMPANY.	
No.	570
Date	12-11-18
08.00	

W.A.

Captain, A.E.
For C.O. 1st Australian Tunnelling Coy. A.E.

354

APPENDIX 8

APPENDIX N^o 8

1st AUSTRALIAN TUNNELLING COMPANY.	
No.	5/45
Date	5-11-18

11

Captain Bewry.

Please move No 1. Section less Lieut. Jensen's party to REJET de BRAULIEU and billet there tomorrow.

4 ~~3~~ lerries will be available at 7 a.m. Give effect to the attached order with at least half of your force.

If further lerries are available balance of No. 3 Section at present at this Headquarters will also be moved and billeted with you at REJET de BRAULIEU. They will be detailed to work under you.

Stone Dump at CATILLON
Horse Transport - 12 G.S. Wagons of 18th Aux.
H.T. reporting to REJET de BRAULIEU

W. J. ...

Captain, AE.

Per C.O. 1st Australian Tunn. Company, AE.

5-11-18.
22.00

APPENDIX No 8

17

1ST. AUSTRALIAN TUNNELLING COMPANY A.E.

WORK ORDER FOR 30/11/18.
by,

Major E.S. Anderson, M.C.

Headquarters
(MARBAIX)
29/11/18.

O.C., No. 4 Section.

MOVEMENT

Please move your Section complete to vicinity of MONT MARCHIENNE or MARCHINELLE (Near CHARLEROI) according to billet accommodation available, leaving MARBAIX by 12.00 30/11/18.

TRANSPORT.

No motor transport is available, No.2 Section Horse transport is placed at your disposal.

BILLETS.

Reconnaissance of area (NAMUR, Sheet 8 squares 1.E. and those parts of 1.E., 2.E. and 2.F. shown on attached tracing. Search for D.A. and other mines, particular attention to railways. Remove all charges and fill in galleries. (F)

REPORTS.

Reports to this Headquarters at 18.00 daily.

RATIONS.

Rations from this Headquarters.

Wm. J. ...
Capt. A.E.

APPENDIX N° 8.

IST. AUSTRALIAN TUNNELLING COMPANY A.E.

16

Headquarters
29/11/18.Officer Commanding
No. 2 Section

Hereunder copy of Work Order issued to No. 1 section for
29/11/18 :-

"Please detail 1 Officer and 12 Other Ranks to proceed at
once per lorry to give effect to the following order:-

" Withdraw the charges from bridge over SAMBRE at
FONTAINE VALMONT AAA
Withdraw charges from bridge over SAMBRE 1 kilo. N.W.
of LOBBES on the branch line towards LINEROEUL."
Party will carry mid-day rations.

(sd) W.J. McBRIDE Captain A.E.
for Commanding Officer.

Officer Commanding
No. 2 Section.

Please arrange to complete the work detailed in
above order on 1st December and also investigate the additional
~~charges~~ charges mentioned in Progress Report of No. 1 Section
attached hereto.

W. J. McBride
Captain A.E.
for Commanding Officer.

APPENDIX N°8

IST. AUSTRALIAN TUNNELLING COMPANY A.E.

14

Work Orders for 30-11-18

By

Major E.S. Anderson M.C., Commanding Officer.

Headquarters
MARBAIX
29-11-18.

O.C.No.1.Section,

MOVEMENT.

Please have your Section ready to move complete by Lorry to vicinity of CHATELET at 13.00 hours 30-11-18.

BILLETS.

Billets will be reconnoitred.in the morning.

WORK.

Reconnaisance of area (Namur Sh. 8., Squares IG.IH and those parts of 2G, 2H, 2I and IH. shown on the attached tracing. Search for D.A.MINE and other Mines, particular attention to Railways. Remove all charges and fill in galleries.

REPORTS.

Reports to this Headquarters at 18.00 hours daily.

RATIONS

Rations from this Headquarters.

(Sgd.) W.J.McBride Captain A.E.
for C.O.Ist.Australian Tunnelling Company A.E.

APPENDIX N°8.

IST. AUSTRALIAN TUNNELLING COMPANY A.E.

15

e-c

Work Orders for 30-11-18

By

Major E.S. Anderson M.C.

Headquarters
MARBAIX
29-11-18

O.C.No.2.Section,

Please detail 1 officer and 1 Squad complete to carry out the following work leaving here MARBAIX at 07.30 hours.

- (1) Fill in galleries under Roads near DONSTIENNES 3D.6.5.4.5.
3D.7.6.4.2.
- (2) (a) Investigate 2 Shafts at 3d.22.52. near STREE .Unload if necessary and fill in. (b) Investigate Xroads 3D.22.56.near STREE.Action as in 2a .(c) Investigate Xroads 3C.9.3.6.4. near Culvert.Fill in Galleries. (d) Investigate "T"Roads 3D.0.8.4.2. near STREE.Unload 2 Shafts if necessary each side of road and fill in.

IST.AUSTRALIAN TUNNELLING COMPANY A.E.

Work Orders

*W. J. McBride
Capt A.E.*

APPENDIX N^o 8

13

354
1ST AUSTRALIAN TUNNELLING COMPANY A.E.

WORK ORDERS FOR 30/11/18.

by,

Major E.S. Anderson M.C., Commanding Officer.

Headquarters
(MARBAIX)
29/11/18.

O.C., No.3 Section.

MOVEMENT.

Please move your Section complete to HESTRUD, Map Ref. NAMUR 1/100,000, 4.B.85.42. leaving MARBAIX at 08.00, 30/11/18.

TRANSPORT.

4 Motor lorries will leave here at 08.00 sharp to BEAUMONT and must return promptly to enable No.4 Section to move at 13.00.

WORK.

Quarrying stone for road metal, assisting 344th Road Construction Company.

RATIONS.

48 hours rations will be carried, thenceforward rations will be drawn from 344th Road Construction Company.

TOOLS ETC.

All tools, timber, forges, anvils, hammers, Foden transport necessary for the conduct of the operations, will be drawn by arrangement from 344th Road Construction Company.

ORDERS.

All orders for work and administration will issue from this Company Headquarters (1st Australian Tunnelling Company).

REPORTS.

Daily if necessary to this Company Headquarters.

CARPENTERS.

2 Carpenters from Company Headquarters will accompany the Section to construct a loading platform.

CORPS ROADS OFFICER.

Major PITMAN, 4th Corps Roads Officer, will render every assistance when consulted.

(Sd) W.J.McBRIDE Capt.A.E.

Copy APPENDIX 8
 IST. AUSTRALIAN TUNNELLING COMPANY A.E.

Headquarters
 29/11/18.

Officer Commanding
 No. 2 Section

Hereunder copy of Work Order issued to No. 1 Section for
 29/11/18 :-

"Please detail 1 Officer and 12 Other Ranks to proceed at
 once per lorry to give effect to the following order:-

" Withdraw the charges from bridge over SAMBRE at
 FONTAINE VALMONT AAA
 Withdraw charges from bridge over SAMBRE 1 kilo. N.W.
 of LOBBES on the branch line towards LISEROEUL."
 Party will carry mid-day rations.

(Sd) W.J.McBRIDE Captain A.E.
 for Commanding Officer.

Officer Commanding
 No. 2 Section.

Please arrange to complete the work detailed in
 above Order on 1st December and also investigate the additional
~~xxxxxx~~ charges mentioned in Progress Report of No. 1 Section
 attached hereto.

W. J. McBride

Captain A.E.

for Commanding Officer.

354

WORK ORDERS.

1ST AUSTRALIAN TUNNELLING COMPANY A.E.

1. The Main Line CHARLEROI - NAMUR has been examined by 174th (T) Co. No charges were reported.
2. On completion of Main Line Railway search in area already allotted, the Area will be extended Northward to include the following Main Line Railways and branch lines between them.

NIVELLES - OTTIGNIES - LOUVAIN

from NIVELLES to H.3.80.40.

CHARLEROI - OTTIGNIES

BRUSSELS - NAMUR

from F.3 10.40. - NAMUR

This may influence your choice of billets for sections.

3. Particular attention will be paid to the destruction of explosives which are not required.

Cases and packets must be broken open, and the explosive scattered.

4. Delayed Action Mines.

It is not anticipated that many of these will be found.

Should a D.A. Mine be suspected on a Railway which is operating, the Belgian or British Railway Authorities should be notified before any search is made.

Arrangements should then be made to carry out the search in close liason with the Railway Authorities; if it is considered of great importance that the charge be removed if possible without interruption to traffic arrangements will be made to obtain P.C.W. to carry out the work.

If traffic can be interrupted, the rails should be moved, and small charges exploded to try and set off the mine.

Every precaution will be taken to minimise risk to British personnel, but at the same time suspected charges must be investigated, otherwise trains may be wrecked.

(Sd) L.E.HILL, Lieut.Col. R.E.
Controller of Mines
Fourth Army.

30/11/18.

(2)

Officers Commanding
Nos. 1, & 4 Sections.

As opportunity offers, reconnoitre the areas above mentioned with view to central billets:-

No. 1 Section East of the line dividing the M square equally N. & S.

No. 4 Section West of the line dividing the M. square equally N. & S.

N.W. Europe Sheet 1, and part of 4 herewith.

W. J. ...
for Commanding Officer.

Captain A.E.

354
 1ST AUSTRALIAN TUNNELLING COMPANY A.E.

Headquarters
 30/11/18.

Officer Commanding
 No. 2 Section.

The following copy of wire received is forwarded
 for your information and action please,
 Please report completion.
 The following map references on Sheet 52 are as
 follows on 1/100,000 Map (NAMUR):-

40,000

100,000

C.21.d.8.7.

D.2.30.15. due east of LOBBES
 Railway over river.

D.2.a.4.4.

D.2.95. Tunnel S.W. of LANDELLIES.

(Copy of Wire).

Controller of Mines
 4th Army.

Senders No.
 W.2810

Date.
 28

"On the line FONTAINE VALMONT demolition charges are still
 on the girders as far as bridge at Sheet 52 C.21.d.8.7. AAA

It is reported that tunnel at D.2.a.4.4. is mined AAA
 Can these charges be removed".

R.C.B.4 R.R.D.

W.A.

Captain A.E.

for Commanding Officer.