

AWM4
Australian Imperial Force unit war diaries,
1914-18 War

Tunnelling & Survey

Item number: 16/3/17

Title: 2nd Australian Tunnelling Company

April 1918



AWM4-16/3/17

No. 2
AUSTRALIAN
TUNNELLING COY.
No.
Date

18,000-12/1 -8723

CONFIDENTIAL.

ORIGINAL.
~~DUPLICATE.~~
~~TRIPLICATE.~~

Australian Imperial Force.

WAR DIARY

OF

2nd Australian Tunnelling Coy.

FOR

April = 1918.

Signature of Officer compiling

[Handwritten signature]

Signature of Officer Commanding

[Handwritten signature]

No. 2
2nd AUSTRALIAN TUNNELLING COMPANY.

No.....
Date..... S U M M A R Y.

Reference sheets.....62D and 62 E,
HEADQUARTERS situated at QUERRIEU.....Sheet 62/D
H 17c 1.8. H 16 d 9.9.

The Unit was administered by and worked under V11th Corps until the 6th, when the Australian Corps took over.

In anticipation of the enemy continuing his offensive, both Corps rapidly pushed ahead with defensive work. Early in the month the Company was concentrated on the improvement, extension and wiring of an old French defence line, known as the BAISIEUX - RIBEMONT LINE. (See Attached plan Appendix A No. (XXX11)

On the 4th inst the question of demolition of bridges in AMIENS in case the enemy occupied that city, was discussed.

The O.C. conferred with the Controller of Mines, and Chief Engineer Third Army and a preliminary reconnaissance was made. Work was started, but stopped after a few hours owing to objections raised by the French Authorities. These were overcome and on the 7th work recommenced and continued until all bridges were prepared for demolition. On the 22nd the control of these bridges passed to 3rd Corps and the work of guarding them was handed over to 172nd Tunnelling Coy. R.E.

On the 11th the responsibility for the guarding and demolition of bridges at LA NEUVILLE and DACOURS was taken over by the Unit. The number controlled was gradually increased until eventually the Company had charge of all bridges in the Corps Area, over the Somme and Ancre. These bridges are marked on plan Appendix A No. (XXX11) and catalogued in orders included in Appendix No. (XV11). As will be seen from these orders, the system of control adopted was to divide these bridges into four groups, each under a responsible officer with detailed orders as to their demolition in case of an enemy attack and advance. Subalterns were stationed in central positions close to their bridges. Sentries were posted over each bridge.

On the 12th the Australian Corps issued a scheme for the construction of defence lines. Major. E.N. MULLIGAN, D.S.O. was placed in charge of the BAISIEUX - ANCRE Line (See diary for the 12th). Officers and men not employed on demolition who were working on Baisieux - Ribemont Line were then transferred to this line.

Four Labour Companies were also employed.

On the 22nd the officers and men who had been employed in No. 3 Group (AMIENS) became available for other work owing to 172nd Tunnelling Coy. R.E. taking over. These men were then employed in constructing tunnelled Machine Gun Dugouts at various sites selected by an officer of "G" Staff. Australian Corps. E Company of 6th United States Engineers arrived in the area on the 29th and was attached to the Unit to assist in this dugout work by orders of the C.E. Australian Corps. Three tunnel dugouts were also commenced on the 29th.

Machine Gun Dugouts commenced at the following positions :-

I 11 c 7.6.	I 10 d 4.8.	I 16 a 8.7.
I 15 d 7.7.	I 21 b 2.9.	I 28 a 1.6.

Observation Posts.

I 24 d 3.2.	J 20 a 4.6.	J 30 c 13.06.
-------------	-------------	---------------

(Continued over page.)

SUMMARY. (Continued).

In addition to the above, a report was compiled on the dugout and cellar accommodation in the Units sector. (See Appendix A No. XXV.)
Strength. Casualties were fairly heavy during the month and were chiefly due to gas shelling, preliminary to the enemy attack on VILLERS - BRETTONEAUX.

Transport. The Horse Transport was augmented by the attachment of 4 extra G.S. Waggon, teams and drivers from the 46th Reserve Park.

The work of the Motor Transport was normal.

Throughout the period Lieut R.J. ROBIN remained ~~on~~ attached to Vth Corps as Roads Officer.

Lieut. G.A. COOK was also attached to the Aust. Corps Heavy Art. in connection with the scheme for the withdrawal of engineer Units in the case of an enemy attack. (See Appendix A No. XI).

1/4/18.

No 2
AUSTRALIAN

Work continuing on BAISIEUX - RIBEMONT LINE.
Unit administered by O.C. Corps Troops, VIth Corps.
Australian Official Photographer visited Unit and took photos
of men going up on shift (See Photograph Appendix A No. (XXX).
Quarter masters Dept. 31% Fresh Meat drawn, the balance being
made up with Pres. Meat. Full ration of Fresh Vegetables
drawn and issued. 31% Bread drawn and 69% Biscuits.
Rum was drawn as usual for men working in advanced positions.
Weather fine.

2/4/18.

Working on Baisieux - Ribemont Line. A plan is attached
showing trenches and wiring. See Appendix A No. (XXXI).
Lieut D. BRIGSTOCKE and detachment which had been working
ROCQUIENY SAW MILL reported back to Unit after delivering the
machinery to R.E. Depot ABBEVILLE.
Mr F.M. CUTLACK, Assitant War Correspondent to A.I.F. visited
Unit to obtain information regarding the recent operations.
Quarter masters Dept. Fresh Meat decreased to 29%, balance
made up with Pres. Meat. and M & B.
On this day we drew two days rations owing to the company
being transferred to the Australian Corps.
Weather Fine.

3/4/18.

Work proceeding on Defence Line.
Quarter Masters Dept. (See report 2nd inst).
Weather fine.

4/4/18.

O.C. conferred with the Controller of Mines at ABBEVILLE
re the demolition of bridges leading into AMIENS from the
North side, and comprising approximately 9 steel and 4 brick
bridges. A scheme was also discussed for the inundation of
the north side of Amiens, by the damming of the SOMME.
O.C. also interviewed C.E. 3rd Army regarding the demolition
of the bridges. After receiving instructions to prepare them
for demolition O.C. pointed out that they were all guarded
by French sentries, and that unless the permission of the
French had been obtained, these sentries would stop the work.
Capt. A.F. COHEN and Lieut C.H. BLUMER with 30 O.Rs, tools
and explosives were sent into AMIENS and started preparing
the bridges at 4 p.m. (See Appendix A No. (XI).
In some places the work was stopped by french sentries.
At 8.30 p.m. all work was stopped by instructions from 3rd ARMY.
About 30 shells fell in the town close to H.Qrs. (QUERRIEU)
Quarter Masters Dept. 41% Fresh Meat drawn, balance in Pres.
meat. 50% Bread drawn. A full ration of all other items drawn
No Rum drawn.
Rained practically all day.

5/5/18.

Work proceeding on Defence Line.
Quarter Masters Dept. 38% Fresh Meat balance Pres. Meat.
75% Fresh vegetables drawn and issued plus 15% from stock.
56% Bread drawn. Butter drawn and issued. No rum drawn.
Weather dull.

6/4/18.

No. 2
AUSTRALIAN
TUNNELLING COY.

AUSTRALIAN CORPS took over sector from V11th Corps.
C.R.E. Aust. Corps Troops, Lieut-Col E.J.H. NICHOLSON. D.S.O.
visited H.Qrs to find what work the Company was doing and
discuss future work.
Orders (See Appendix A No. (X1) received from C.E. V11th
Corps to hold in readiness 3 Officers and 100 O.Rs for
bridge demolitions in AMIENS. See Diary for 4th inst when
this work was cancelled.
Work as usual on Baisieux - Ribemont Line.
Quarter masters Dept. 40% Fresh Meat drawn, balance received
in Pres. Meat and M & B. Full issue of vegetables 50%
Bread and 50% biscuits. No rum drawn.
Weather fine.

7/4/18.

III Army relieved by 1Vth Army.
O.C. visited the bridges and locks in AMIENS with
Controller of Mines 1Vth Army.
Chief Engineer, Aust Corps ordered 3 officers and 100 O.Rs
who were standing by to proceed to AMIENS to prepare
bridges for demolition. (See Appendix A No. (X1).
Capt. A.F. COHEN, Lieut C.H. BLUMER and Lieut L.L. WRATHALL
with 100 men were accordingly sent off at noon, and work
was commenced during the afternoon. Officers and men
were billeted near the work, Boulevard du Jardin des Plantes.
AMIENS heavily shelled during the day and bombed at night.
Quarter Masters Dept. 50% Fresh Meat drawn balance in
Pres. Meat and M & B. 60% Bread. No rum drawn.
Weather fine.

8/4/18.

Lieut-Colonel LOGAN. R.A.M.C. Director of Medical Services
for Tunnelling Coys, visited the Company.
C.R.E. Aust. Corps inspected work on Baisieux - Ribemont
Line.
Quarter Master Dept. 50% Fresh Meat drawn balance in Pres.
Meat. 60% Bread. Butter drawn and issued. Rum drawn
for men working in advanced positions.
Weather fine.

9/4/18.

Heavy shelling in vicinity of billets in Amiens. One
of the billets was struck killing one man and wounding two.
Quarter masters Dept. 60% Fresh Meat drawn, balance in
Pres. Meat and M & B. 72% Bread. Tobacco and Cigarettes
drawn and issued, but no matches. Rum drawn as on the 8th.
Weather fine.

10/4/18.

Aust. Corps decided on a definite plan of withdrawal of
Engineer Working parties, should the enemy succeed in making
an advance. These orders were communicated to the O.C.
by the Chief Engineer and transmitted by him to 180 Coy. R.E.
This Company and 180 Coy. R.E. each supplied an officer
to live at Corps Heavy Artillery Headquarters at MONTIGNY.
In the event of a withdrawal becoming necessary this officer
would be notified and would then warn all engineer units
by motorcycles. The two officers would follow different
routes but warn the same units. These verbal orders were
confirmed in attached message. (See Appendix A No. (X11).

(continued over page)

10/4/18.

(contd)

No. 2
AUSTRALIAN
TUNNELLING COY

Lieut G.A. Cook sent on this duty.

In view of above all heavy stores that were not required for the moment were sent to PIERREGOT which the Chief Engineer had appointed as a rendezvous. The Company was then made extremely mobile.

A report (See Appendix A No (X1) sent to the C.E. 1Vth Army regarding bridges being prepared for demolition.

Quarter Masters Dept. 81% Fresh Meat drawn, balance Pres. Meat. Full issue of Bread drawn and issued, butter and Rum drawn.

Weather fine.

11/4/18.

.....
Instructions received from C.E. Aust. Corps. to take over the responsibility of guarding and demolishing all bridges at LA NEUVILLE and DAOURS from 178th Tunnelling Coy. R.E. which was moving out (See Appendix A No X111).

Capt. L de J. GRUT took over and 35 men were sent out and posted as sentries on the bridges. Some of the bridges were already prepared, but the majority were incomplete. Technical instructions regarding work on Defence Line received from C.R.E. Corps Troops (See Appendix A No. (XIV). Part 2.

Quarter masters Dept. 75% Fresh Meat drawn. Balance as yesterday. Bried Fruits in lieu of jam. 84% Bread. Matches drawn 1 box per man.

Weather fine.

12/4/18.

.....
The system of organisation of the Corps line changed. The line was divided into sectors, each under the control of a responsible officer, who was to have certain labour at his disposal. C.R.E. C.T. to supervise the whole. Major E.N. MULLIGAN. D.S.O. O.C. 2nd Australian Tunnelling Coy. was given control of the BAISIEUX - ANCRE Line with the following labour. 2nd Australian Tunnelling Coy and 53rd Labour Group less one Company (leaving 4 companies) (See Appendix A No. (XIV. Part 1.)

The Baisieux - Ancre Line runs roughly parallel to the Ancre from Bonnay to Ribemont, then towards Baisieux. (See Appendix A No. (XXX1) and (XXX11).

Great difficulty in getting explosives and stores for demolition work. Bridges in vicinity of DAOURS and LA NEUVILLE, being prepared (See Appendix Map A No. (XXX11).

Quarter masters Dept. 60% Fresh Meat drawn balance in Pres. Meat and M & B. 37% Bread.

Weather fine.

13/4/18.

.....
Work started on Baisieux - Ancre Line near Bonnay in lieu of Baisieux - Ribemont line which is now fairly complete. A total of 921 men employed on this work, from 53rd Labour Group and 289 sappers of the Coy. Quarter masters Dept. 64% Fresh Meat. 80% Bread. Butter drawn.

Weather wet.

No. 2
 AUSTRALIAN
 TUNNELLING COY.

14/4/18.

General Sir. W.R. BIRDWOOD. K.C.B., K.C.S.I., K.C.M.G., C.I.E.
 D.S.O., A.D.C. G. O. C. A.I.F. visited the Company at work
 on the BALSIEUX - ANCRE Line.

Weather Fine.

Quarter masters Dept. 60% Fresh Meat balance Pres. Meat.
 76% Bread, Butter and Pickles drawn.

15/4/18.

Aust. Corps took over the responsibility for the demolition
 of all bridges in AMIENS. Letter from C.E. Aust. Corps.
 (See Appendix A No. (XV). In accordance with these orders
 Aust. Corps were supplied with a copy of Demolition
 Instructions No. 1 by Major. E.N. MULLIGAN. D.S.O. (See
 Appendix A No. (XVI). These instructions covered all bridges
 in the Corps area, and divided them into four groups, each
 under the control of a responsible officer.

No. 1. Group comprised bridges in the following areas.

CORBIE.
 LA NEUVILLE.
 DAOURS.
 FOUILLOY.

No. 2. Group.

BONNAY.
 RIBEMONT.
 HEILLY.
 BUIRE.

NO. 3 Group.

AMIENS.

No. 4. Group.

LA MOTTE-Brebiere.
 CAMON.
 LONGUEAU.
 BLANGY-TRONVILLE.

Sentries are posted on all these bridges, and those not
 already prepared for demolition are rapidly being comple-
 ted.

Quarter masters Dept. Only 2 oz Bacon per man drawn. the
 other two ozs made up with M & B. Other issues the same
 as yesterday, with exception of butter and pickles.
 Weather fine.

16/4/18.

Orders received for bridge "K" at La Motte to be taken
 over from 6th United States Engineers and added to No. 4
 Group. (Capt. G.L. SMITH) See Appendix. (XIII). On
 going to take the bridge over Capt. Smith found it in
 charge of 172nd Tunnelling Coy. See Appendix (XIII).
 Report on Bridges at DAOURS see Appendix A No. (XXI).
 Work continued on Baisieux -Ancre Line under Capt. F.G.
 PHIPPARD.

Quarter masters Dept. The same percentage of Fresh Meat
 and Bread were drawn as the 15th. 2 ozs Bacon drawn
 instead of 4 ozs. Balance made up with M & B.
 There was a shortage of cheese, our proportion being
 only 16 lbs. instead of 66lbs. Pork and beans drawn for
 the first time for some weeks. The issue average 3 men
 per tin.

APRIL 1918.

17/4/18.

BRIDGE "K" La Motte taken over from 172nd Tunnelling Coy.

R.E.

C.C. discussed bridge demolition question with C.R.E. 3rd Division

C.E. stated that he was allotting 100 men of 63rd Labour Group to the Company. (See Appendix A No. (X1).

Work continued on Baisieux - Ancre Line under Capt. F.G. PHIPPARD.

Quarter masters Dept. 55% Fresh Meat drawn, balance Pres. Meat. 76% Bread drawn. Veal loaf issued in lieu of cheese. 2 ozs bacon issued balance in M & B. Weather wet.

18/4/18.

100 men of the 63rd Labour Group reported, 50 men were sent into AMIENS and attached to No. 3 Group. The remainder detailed for work on the Baisieux - Ancre Line.

Reports on bridges received from Group Commanders (See Appendix A No. (X1).

C.C. issued Appendix A to demolition instructions (See Appendices A Nos. (XVI, XVII, & XVIII). This gave the locations of all Group Commanders and their Subalterns.

Work on the Baisieux - Ancre Line continued under Capt. F.G. PHIPPARD.

68% Fresh Meat drawn Pres. Meat drawn making up balance. 80% Bread drawn. Butter drawn and issued. Veal loaf drawn in lieu of cheese M & B drawn in lieu of bacon. Salt was sent to each cookhouse.

Weather wet.

19/4/18.

New bridges reported complete at N 6 d 7.5., O 5 c 5.5. O 5 c 5.8. In accordance with C.E. instructions, arrangements made for their demolition. (See Appendix A No. (X11). Summary of Company's work sent to Controller of Mines, 1Vth Army (See Appendix A No. (X11) Part 3.

In view of the fact that mining work is likely to be started early and allotment of 50% of sets received at QUERRIEU dump given by C.E.

Quarter masters Dept. 68% Fresh Meat drawn, Pres Meat drawn making up balance. 87% Bread drawn. Butter drawn and issued. Veal loaf drawn and issued in lieu of cheese. Full issue of bacon drawn. Mustard sent to all cookhouses. Rum drawn as usual for men working in advanced positions.

Weather dry and bright.

20/4/18.

C.E. Aust. Corps. ordered all bridges to be provided with a notice board carrying the serial No.

Bridges Nos 11, 12, 13 and 14 taken off list as they will remain in 3rd Corps area owing to a slight readjustment of the Corps boundary.

Arrangements made to hand over all bridges in No. 3 Group, AMIENS over to 172nd Tunnelling Coy. R.E. this releasing one section for dugout work.

Supply of dynamo exploders for firing bridge charges received.

Working on the Baisieux - Ancre Line under Capt. F.G. PHIPPARD.

Quarter masters Dept. 63% Fresh Meat drawn M & B and Pres. Meat making up balance. Same per cent of bread as yesterday

XX

21/4/18.

The work of placing notice boards on the Baisieux - Ribemont line begun.

Working on the Baisieux - Ancre Line under Capt. PHIPPARD. Allotment of mining timber altered by C.E. : 180th Tunnelling Coy. R.E. to have all sets and this unit all Beech slabs. (See Appendix A No. (XI) Part 2.

Company Headquarters moved from No. 3 Marconi Street to No. 3 Lombard Street, Querrieu -- a distance of about 100yds. Quarter Masters Dept. 60% Fresh Meat drawn, Pres meat making up the balance. 76% Bread drawn. Butter drawn and issued. Full issue of cheese and bacon drawn. Rum authority cancelled. Weather fine.

22/4/18.

O. C. met O.C. 172nd Tunnelling Co. R.E. in AMIENS and handed over all bridges prepared for demolition. (See Appendix A No. (XI). Officers and other ranks who had been doing this work returned to Headquarters.

Since the Unit was at Ytres "A" Section 179th Tunnelling Coy under Capt. G.G.SALE. R.E. has been attached. Orders (See Appendix A No. (XIX) now received for them to move to SIBIVILLE for work under 3rd Army.

Capt. A.F.CHOEN visited sites for proposed Machine Gun Dugouts with Major. R.G.CASEY. DS.O.M.C. ("G" staff. Aust Corps.)

Quarter masters Dept. 57% Fresh Meat drawn, balance in M & B. 72% Bread drawn. Other issues similar to yesterday. Weather fine.

23/4/18. "A" Section 179th Tunnelling Coy. R.E. moved off at 8 a.m. for SIBIVILLE.

Working on Baisieux - Ancre Line under Capt. F.G. PHIPPARD. Quarter masters Dept. All rations drawn same as yesterday. Weather fine.

24/4/18. Enemy attacked and took VILLERS-BRETTONEAUX. Heavy shelling and gas shelling of BONNAY, CORBIE ETC., causing a number of casualties in the Coy.

Quarter masters Dept. 60% Fresh Meat drawn, balance Pres Meat. 76% Bread drawn. Butter drawn and issued. Full issue of all other rations. Weather fine.

25/4/18. C.R.E. Aust. Corps Troops visited work on Baisieux - Ancre Line.

Weekly report (See Appendix A No. (XII) Part 3. submitted to Controller of Mines 4th Army.

Arrangements made for Capt. A.F.COEN to start work on Machine Gun Positions and Dugouts at sites already located.

Quarter Masters Dept. 57% Fresh Meat drawn, balance in Pres Meat. 70% Bread drawn. Dried Fruit drawn in lieu of Jam and issued. Jam was issued from stock also. Weather fine and bright.

26/4/18.

 AUSTRALIAN
 TUNNELLING COY
 No.....
 Date.....

Work started by No. 4 Section (Capt. A.F. COHEN) on Machine Gun Dugouts in Corps line. (See Appendix A No. XXIV copies of correspondence. A forward camp started in connection with this work on the fringe of Bois d'Escardonneuse.

Quarter masters Dept. 63% Fresh Meat drawn M & B and Pres Meat making up balance. 73% Bread drawn. Pickles were drawn but not enough to issue. 2 oz Bacon drawn. M & B drawn in lieu of other 2 ozs. Weather fine.

27/4/18.

Controller of Mines 4th Army visited Headquarters. Arrangements made to draw supplies of mining timber from Poulainville R.E. Dump. 114th Labour Coy., detailed for work under this unit, arrived in Corps area and reported for orders and accommodation. Camped in tents on fringe of Bois d'Escardonneuse. at I 15 a 3.6. Shifts detailed as fatigues to tunnellers making machine gun dugouts. Balance of Company detailed for work on Baisieux - Ancre Line under Capt. F.G. PHIPPARD. Quarter masters Dept. 60% Fresh Meat drawn pres. Meat making up the balance. 76% Bread drawn. Butter drawn and issued. Half issue of bacon M & B in lieu of other half. Weather fine and bright.

28/4/18.

Lieut Wolaben of the United States Engineers reported with 2 N.C.Os from E Company, 6th United States Engineers. To be attached for instructions in tunnelling. Detailed to No. 4 Section. C.E. Aust. Corps. asked for proposals regarding dugouts (See Appendix A No. (XXI)). Quarter masters Dept. 60% Fresh Meat drawn, balance Pres Meat and M & B. Bread same as yesterday. Tobacco and matches drawn. Rice drawn but not sufficient to issue. Condiments sent to No. 4 section. Weather wet.

29/4/18.

"E" Coy 6th U.S. Engineers arrived and went into billets at FRANVILLERS. Attached to No. 4 Section. (Machine Gun Dugout work) See Appendix A No. (V). Plan. No. (XXVII). Tunnel dugouts for Observation Posts commenced at following points under Lieut. C.H. BLUMER. :-
 J 30 c 2.2. J 24 d 3.3. J 20 a 5.6.
 See Appendix A No. (V). Plan. No. (XXVII). Owing to these positions being under direct enemy observation they could only be worked at night. Quarter Masters Dept. 56% Fresh Meat drawn, balance in Pres Meat. 74% Bread drawn. Butter drawn and issued. Weather wet.

30/4/18.

C.E. ordered a complete survey to be made of all existing dugouts, caves and tunnels (See appendix A No. (XXV)). Capt. F.G. PHIPPARD and Lieut. E.M. TOOTH detailed to report on all known shelters of this nature in this area. Quarter masters dept. 58% Fresh Meat drawn, balance in Pres Meat and M & B. 74% Bread drawn. 18lbs Candles drawn. 2 days rations were drawn for men on demolition work. Rum drawn and issued. Weather wet.



APPENDIX WAR DIARY

OF

2nd AUSTRALIAN TUNNELLING COY.

FOR

APRIL 1918.

Marked A.

LIST OF APPENDICES.

No.	Subject.
(1).	MONTHLY LIST OF OFFICERS.
(11).	DAILY PARADE STATE for 30/4/18.
(111).	COPY of DAILY REPORT to C.R.E. Parts 1, 2, 3, & 4.
(IV).	COPY of DAILY REPORT to C.E. Parts 1, 2, 3, & 4.
(V).	WEEKLY REPORT (Dugout work). weekending 30/4/18.
(VI).	WEEKLY REPORT HORSE TRANSPORT. Parts 1, 2, 3, 4.
(VI1).	GRAPH shewing TON-MILEAGE HORSE TRANSPORT.
(VI11).	WEEKLY REPORT MOTOR TRANSPORT. Parts 1, 2, 3, 4.
(IX).	GRAPH shewing TON-MILEAGE MOTOR TRANSPORT.
(X).	WEEKLY REPORT MOTOR CYCLES. Parts 1, 2, 3, 4.
(XI).	DEMOLITIONS AMIENS. Copies of Orders from Controller of Mines. C.E. Aust. Corps. C.E. VIth Corps.
(XI1).	SECRET INSTRUCTIONS from C.E. Aust Corps. Withdrawal in case of attack.
(XI11).	DEMOLITIONS Daours. La Neuville. Corbie. etc. Instructions and Reports. Parts 1, 2, 3.
(XIIV).	DEFENCE INSTRUCTIONS. Organisation. Part 1. do. Notice Boards. Part. 2.
(XV).	SECRET INSTRUCTIONS. from C.E. Aust. Corps. DEMOLITIONS.
(XVI).	DEMOLITION INSTRUCTIONS. No. 1 Group Commanders.
(XVI1).	LISTS OF BRIDGES.
(XVI11).	LOCATION OF OFFICERS.
(XIX).	COPIES OF LETTERS ETC. ATTACHED UNITS.
(XX).	DEFENCE LINE. Copies of Orders. etc.
(XX1).	DEMOLITION WORK. Officers Reports.
(XX11).	C.E. Aust. Corps. Request for proposals for Dugouts.
(XX111).	DUGOUT WORK. Orders for construction.
(XXIV).	DUGOUT WORK. Copies of letters and telegrams.
(XXV).	ORDERS TO SURVEY EXISTING DUGOUTS IN CORPS AREA.
(XXVI).	MEDICAL OFFICERS REPORT.
(XXVI1).	PLANS OF MACHINE GUN POSITIONS.
(XXVI11).	PLANS OF OBSERVATION POSTS.
(XXIX).	PLAN OF AMIENS (showing bridges).
(XXX).	PHOTOGRAPH OF SECTION GOING UP ON WIRING DEFENCE LINE.
(XXX1).	PLAN OF DEFENCE LINE.
(XXX11).	MAP SHOWING DEFENCE LINE AND BRIDGES.
(XXX111).	STATEMENT OF SAPPER. P. MINOGUE. Prisoner of War.

X

ORIGINAL ONLY.

.....

APRIL 1918.

TUNNELLED

Australian Imperial Force

APPENDIX A

Unit: 2nd Australian Tunneling Coy
Station: ...
Date: 30/4/18.

LIST OF OFFICERS.

Grade	Officers on strength doing duty with Unit	Names	Date of being taken on strength as an officer
S.	Major	E. N. MULLIGAN. D.S.O. (O.C.)	1/1/16
S.	Captains -	A.F. COHEN.	1/1/16
S.		L. de J. GRUT.	1/11/16
S.		G.L. SMITH.	1/2/16
S.		F.G. PHIPPARD.	31/11/15.
S.		G.I. ADCOCK.	25/9/16.
S.	Lieutenants -	E.M. TOOTH.	1/1/16.
S.		K.B. LEWIS.	26/9/16.
S.		L. J. LAMBERT.	"
S.		D.C. MACKENZIE.	1/4/16.
S.		D. BRIGSTOCKE.	10/12/15.
S.		J.A. REID.	1/1/16.
M.		L. L. WRATHALL.	25/6/16.
S.		L. STEAD.	25/9/16.
S.		C. H. BLUMER.	"
S.		F. H. HOOPER.	"
S.		A. W. JOHNSON.	"
S.	H. J. P. BROOME.	26/6/17.	
M.	T. B. U. BOWLING.	6/2/17.	
M.	H. V. PETHEBRIDGE.	17/5/17.	
S.	2nd Lieut.	N. A. VEITCH.	19/4/18.

Assistant to O.C. CAPT. G. I. ADCOCK. 25/9/16.

First-Class Warrant Officers doing duty with Unit. Date taken on strength as WO.

Sergeant-Major - J. H. W. MCGAIN. No. 3801. 7/2/17.

Officers attached

Date of joining

Rank	Name	Corps of Reinforcement	Date of joining
S	Capt. G. A. BROOKS.	A.A.M.C. Medical Officer.	27/1/18.

APPENDIX

A1 Officers absent from Unit.

<i>Married or Single</i>	<i>Rank</i>	<i>Name</i>	<i>(a) See below.</i>	<i>Date</i>
M.	Capt.	P. W. WAGSTAFF	Supy 2/Aust. Div Engrs.	27/12/16
M.	"	H. E. TROUSSELOT.	Sec. 1/Aust. Corps School.	20/7/17.
S.	Lieut.	P. CARO.	Supy. A.I.F. England.	6/6/16.
M.	"	G. A. COOK.	Temp Attd Aust Corps. H.A.	19/4/18.
M.	"	R. J. ROBIN.	" 5th Corps.	15/3/18.
M.	"	J. F. PATTINSON.	Hospital sick.	16/3/18.
S.	"	M. TIERNAN.	" WOUNDED GAS.	3/3/18.
S.	"	L. G. WILKINS.	" " " " " " " "	12/3/18.
S.	"	S. HALFORD.	" " " " " " " "	"

Changes of "Ranks" of Officers

<i>Married or Single</i>	<i>Rank</i>	<i>Name</i>	<i>Promotion or Transfer and Reason</i>	<i>Date</i>

Officers and Warrant Officers taken on strength of Unit.

<i>Married or Single</i>	<i>Rank</i>	<i>Name</i>	<i>Reason</i>	<i>Date</i>
S.	2/Lieut.	N. A. VEITCH.	marched in	A.G.B.D. 19/4/18.

Officers and W.O.s quit during month.

<i>Married or Single</i>	<i>Rank</i>	<i>Name</i>	<i>Reason</i>	<i>Date</i>

Officers struck off strength of Unit.

<i>Married or Single</i>	<i>Rank</i>	<i>Name</i>	<i>Reason</i>	<i>Date</i>

No. 2 War Diary
 Appendix No. A2.
 Part

No.
 Date.

DAILY PARADE STATE

DATE

	Officers	Batmen	H.Q.	Defence	Demolitions				Detn	Resting	Sick	Dug Outs	Total for Rations	Hosp	Leave	Total Army Corps	Totals
					No 1 Group	No 2 Group	No 3 Group	No 4 Group									
Officers												23	4		1	28	
Coy. H.Q.	3	2	32									34	2	2		38	
A.S.C.			18									18	1			19	
No 1 Section	6	4	4	5	57				2	2		74	6	1	1	82	
" 2 "	4	4	5	39			46			9		103	6			109	
" 3 "	6	5	3	10		23				4		45	7			52	
" 4 "	4	3	9		4	2				7	44	69	4			73	
Supernumerary			3	1								4	1			5	
Total Coy	23	18	74	55	61	25	46		2	22	44	370	31	3	2	406	
Reinforcements		5	20	39	37	55			12	10		178	5	1	1	185	
Labour Coy				50								50				50	
Artisan Coy			2									2				2	
4th Pioneer Bat			5									5				5	
46th Reserve Pk			4									4				4	
Paymaster.			1									1				1	
	23	23	106	144	98	80	46		14	32	44	610	36	4	3	653	

Lost on Strength from Marched In. Ret'd from Hosp.

No 3 Section, 6130. Polve. A. 592. Lt. Hodgins
 " 7623. Oliver. C. 4147. Perry. W. J.
 " 540. Dunbar. A. J.

No 1 Section 612. Kerr. R.
 " 4 " 6118. Lee. R. W.

On Strength Pk's

7020. Causton
 7503. Harrison. A.
 5631. Taylor. W. G.

Killed in Action

7849. O'Loole. W.
 5704. Barter. G.

Wounded

5951. Jackson. W.
 6678. Woodden. W.
 Sap Mitchell. W.

Shaw Captain
 Assistant to C.O.

APPENDIX 13
 AT

Formation,	Unit.	Strength. Ration. Working.	O.C.	Location,	Working on	Working under,
35 th Labour Group	15 th Lab Coy	Off. 4 - 310. O.R.	Capt. Raddan.	P.O. W. Cage. near Querrieu	La. Neuville - Ribemont Defence	2 nd Australian Tunnelling Coy.
"	105 th Lab Coy	2 - 297	Capt. Toppay.	Querrieu.	" " " "	" " " "
"	175 th Lab Coy	3 - 211	2/Lieut Munter	P.O. W. Cage. near Querrieu.	" " " "	" " " "
"	715 th Lab Coy	2 - 172	Capt. Topigall	P.O. W. Camp Allonville Forest	" " " "	" " " "
63 rd Labour Group	86 th Lab Coy	1 - 100.	2/Lieut Astin	Querrieu	" " " "	" " " "
		12 - 18,090		I. 15 A. 2. 6.		

/ / 18.

G. Murray
Capt, Assist to B.C.
2nd Australian Tunnelling Coy,

APPENDIX
A III
14

UNIT 2nd Australian Tunnelling Coy WORK UNDER C.R.E. AUSTRALIAN CORPS TROOPS.

Part 1.

DAILY REPORT OF WORK ON 20th April 1918 and Labour Distribution on 21st April 1918.

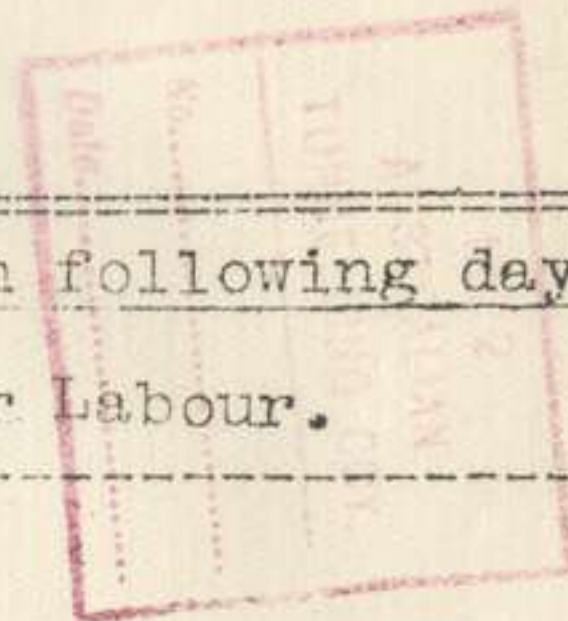

Job Title	Location	Subdivision of work with sub numbers	Total Progress.	Date to complete	Off.	C.R.	Other Labour	Remarks on materials and transport.	Distribution of labour on following day		
									Officers	Sappers	Other Labour.
Lakeville - Ribemont Defences					10	213	Off. O.R. 3-258 2-205 3-275 3-160 11-898	15 th Labour Coy. 85 Labour Coy. 105 Labour Coy. 175 Labour Coy.	12	147	4 Boys. 53 rd Labour Group.
Demolitions					11	235			11	331	

[Signature]
 Captain Assistant to O.C.
 2nd Australian Tunnelling Coy

APPENDIX
 AT 15

War Diary

Appendix No (IV)

UNIT:- 2nd AUSTRALIAN TUNNELLING COY. WORK UNDER C.R.E., AUSTRALIAN CORPS TROOPS.

Part 2

DAILY REPORT OF WORK ON 22nd April 1918 and Labour Distribution on 23rd April. 1918-

Job Title.	Location.	Subdivision of work with sub.numbers.	Total Progress.	Date to Complete.	Off.	O.R.	Other Labour.	Remarks on Material and Transport.	Distribution of labour on following days.				
									Officers.	Sappers.	Other Labour.		
La Neuville- Ribemont defences					12	143	Offs. O's		15 th Labour Coy	16	238	4 Coys. 53 rd Labour Group	
							3 - 255						85 Labour Coy
							2 - 130						105 Labour Coy
							4 - 291						175 Labour Coy
Demolitions					11	320			7	225			
							2 - 160						



/ /1918.

[Signature]
 Capt., Asst. to
 O.C., 2nd Australian Tunnelling Company.

APPENDIX IV
 16

War Diary

Appendix No (IV)
Part 3

Unit Work under C.R.E. Corps Troops Australian Corps.

Daily report of work on 25th April 1918 and Labour distribution on 26th April.....

Job Title	Location	Subdivision of work with sub numbers	Total Progress to Complete	Date	Offs	Sprs	Oth Lab.	Remarks on material and transport	Distribution of Labour on following day		
									Offs	Sappers	Oth Lab
La Neuville - Ribemont & Defence					16	230	4-320	15 th Labor Coy			
							2-158	85 Labour Coy	16	130	53 rd Sapper Coy
							4-299	105 Labour Coy			11 th Sapper Coy
							3-173	175 Labour Coy			Labour Coy
							1-100	86 Labour Coy			62 Labour Coy
Remotations					7	235			7	224	

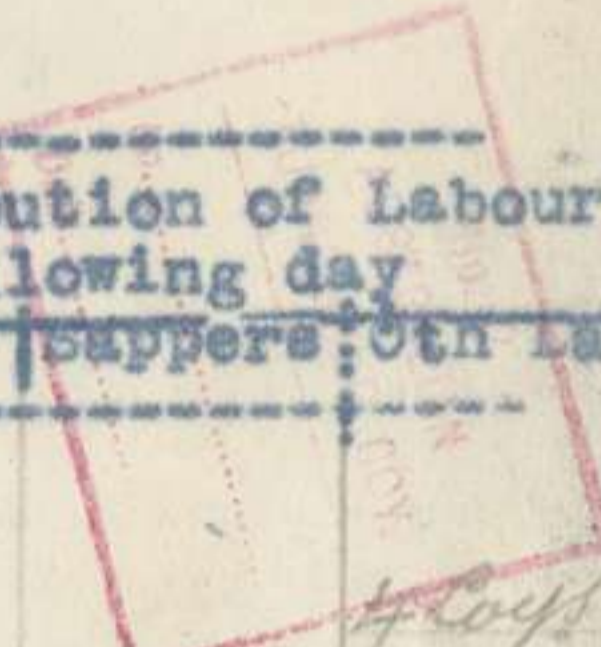

Adams
Capt Asst to O.C.
2nd Australian Tunneling Coy

APPENDIX IV 11

27th April 1918,

Page 4

Job Title..... Location.	Subdivision of work with sub numbers	Total Progress	Date to Complete.	Off	O.R.	Other Labour	Remarks on material & transport.	Distribution of labour on following day.		
								Officers	Sappers	Other Labour.
La-Neuville- - Belmont Defences				10	141	Off. O.R. 4-310 15 th Labour Coy 2-297 105 Labour Coy 3-211 175 Labour Coy 2-172 715 Labour Coy 1-100 86 Labour Coy		9	111	4 Coys of 35 th Labour Group 1 Coy of 83 Labour Group.
Demolitions				10	141	12-1090		9	111	
				7	226			7	215	
Dugouts				4	45			4	55	120 O.Rs. of 114 th Labour Coy
O.Ps.								1	16	

L. H. H. H.
Capt. Assist to O.C.
2nd Aust Tunnelling Coy

APPENDIX A IV

No. 2
 AUSTRALIAN
 Secret. War Diary
 GOV.
 Australian Corps.
 Division.

Appendix No. (V)
 Part. 1.

WEEKLY PROGRESS REPORT.
 (Services other than Mining.)

Date. 1-5-18.

2nd Australian Tunnelling Company P.E.

No.	Loc.	Nature of Work.	Map Reference	Section or employment.	Shifts per day	Personnel		Average working party	Meters completed	Remarks
						45	241			
1		M.G. Dugouts in Chalk	I.11.c.7.6.	4	4	3	2	10	12	6-5-18. S.
2		" " "	I.10.d.4.8.	4	4	3	2	10	12	6-5-18. S.
3		" " "	I.16.a.8.7.	4	4	3	2	10	12	6-5-18. S.
4		" " "	I.15.d.7.7.	4	4	3	2	10	12	7-5-18. S.
5		" " "	I.21.b.2.9.	4	1 1/2	3	2	10	12	8-5-18. S.
6		" " "	I.28.a.1.6.	4	1	3	2	10	12	9-5-18. S.
7		O.P.	I.24.d.3.2.	4	2	1	2		4	13-5-18. S. This position can only be worked
8		" " "	J.20.a.4.6.	4	1	1	2		4	7-5-18. S. at night & at present no lights can be used
9		" " "	J.30.c.13.06	4	2	1	2		4	13-5-18. S. " " "

Signed E. H. Mulligan Major
 CO. 2nd Australian Tunnelling Coy.

APPENDIX

Weekly Horse Transport Report.

Weekly ending - 6-4-18.

F. 2
AUSTRALIAN
TUNNELLING COY.
No.....
Date.....

Horses				Vehicles		Remarks
Horse's Name	Health	If Working	Remarks	No.	Type	
Dorby & Orwing	Good	Yes		1	G.S. Waggon	Yes
Har & Jack	"	"		2	"	"
Sandy & Fred	"	"		3	"	"
Sam & Jimmy	"	"		4	"	"
Tom & Dick	"	"		5	"	"
Walt & Ginger	"	"		4	Double Limber	"
Willie & Fred	"	"		5	Water Cart	"

(Signed) C. E. Smith
Corporal
1/4 Stables

APPENDIX A III

MILEAGE and TONNAGE TABLE

81-A-0

Day.	Date	Miles Travelled	Loads in Tons carried	Tons	Miles	Remarks
Sunday	APRIL					
Monday	1	42	2		84	
Tuesday	2	60	6		360	
Wednesday	3	14	1		56	
Thursday	4	55	6		330	
Friday	5	35	2		70	
Saturday	6	44	7		308	
Total		250	24			<u>General Remarks of Interest.</u>

No. 2
 AUSTRALIAN
 TUNNELLING COY.
 No.....
 Date.....

War Diary
 Appendix No (VI.)
 Part 2

Weekly Horse Transport Report

Weekly ending: 13-4-18

Horses				Vehicles			
Horses Name	Health	If Working	Remarks	No	Type	If Working	Remarks
Darby & Brawny.	Good	Yes		1	C.S. Wagon	Yes	
Kar & Janet.	"	"		2	"	"	
Sandy & V-nie	"	"					
Inner & Jimmy.	"	"		3	"	"	
Tom & Dick	"	"					
Nell & Ginger.	"	"					
Millie & Fred.	"	"		4	Double Limber	"	
				5	Water Cart	"	

(Signed) C. E. Smith
 Corporal
 Co. Stables

APPENDIX
 A IV
 22

MILEAGE and TONNAGE TABLE.

Day.	Date	Miles Travelled	Loads in Tons carried	Tons.	Miles.	Remarks
Sunday	April 7	42	4	168		
Monday	8	42	3½	63		
Tuesday	9	40	4	160		
Wednesday	10	42	3	126		
Thursday	11	40	3½	60		
Friday	12	69	4½	310		
Saturday	13	30	2½	75		

Total 305 25 General Remarks of Interest.

APPENDIX

No. 2
 AUSTRALIAN
 TUNNELLING COY.
 No.....
 Date.....

Weekly Horse Transport Report

War Diary
 Appendix No (VI)
 Part. 3.

Weekly starting 20-4-18.

Horses				Vehicles			
Horses Name	Health	If Working	Remarks	No	Type	If working	Remarks
Dorby & Brown	Good	Yes		1	Gen. Waggon	Yes	
Ka & Jack	"	"		2	"	"	
Buddy & Vinnie	"	"		3	"	"	
Walter & Jimmy	"	"					
Tom & Dick	"	"					
Neil & Ginger	"	"					
Minnie & Bob	"	"		4	Double Limber	"	
				5	Water Cart	"	
8 Horses have been attached to our strength 17-4-18.				4 G.S. Waggon have been attached to our strength. 17-4-18.			

(Signed) C. E. Smith
 Corporal
 of Stables

APPENDIX III

MILEAGE and TONNAGE TABLE.

Day	Date	Miles Traveled	Loads in tons carried	Tons	Miles	Remarks
Sunday	April 14	80	4	320		
Monday	15	54	3½	189		
Tuesday	16	45	3	135		
Wednesday	17	36	3½	126		
Thursday	18	44	2	88		
Friday	19	44	3	132		
Saturday	20	54	3	162		

Total

357

22

General Remarks of Interest.

No. 2
 AUSTRALIAN
 TUNNELLING COY.
 No.....
 Date.....

War Diary

Weekly Horse Transport Report

Appendix No (VI)
 Part 4

Weekly ending 27-4-1918.

Horses.				Vehicles.			
Horses Name.	Health.	If Working	Remarks.	No.	Type	If working	Remarks.
Darby & Jimmy	Good	Yes	Kate & Janet, working with Capt Cohens Section	1	G.S. Wagon	Yes	
Kate & Janet	"	"		2	---	"	
Sandy & Vane	"	"		3	---	"	
Linger & Jimmy	"	"					
Tom & Nick	"	"					
Neil & Ginger	"	"					
Millie & Fred	"	"		4	Double Limber	"	D-Limber, working with Capt. Cohens Section
			8 Horses still attached	5	Water Cart	"	
							4 G.S. Waggons still attached

(Signed) E. E. Smith

Captain
 Co. Signals

APPENDIX A
 Page 6

MILEAGE and TONNAGE TABLE.

Day.	Date	Miles Travelled	Loads in Tons carried.	Tons	Miles.	Remarks
	April					
Sunday	21	100	6	600		
Monday	22	80	5	400		
Tuesday	23	78	4½	351		
Wednesday	24	77	4½	346		
Thursday	25	30	1½	45		
Friday	26	65	4	260		
Saturday	27	65	4½	292		
		495	30			

General Remarks of Interest.

APPENDIX

No. 2
AUSTRALIAN
TUNNELLING COY.

War Diary
April 1918

Horse Transport
Ton Mileage

Appendix A No (VII)

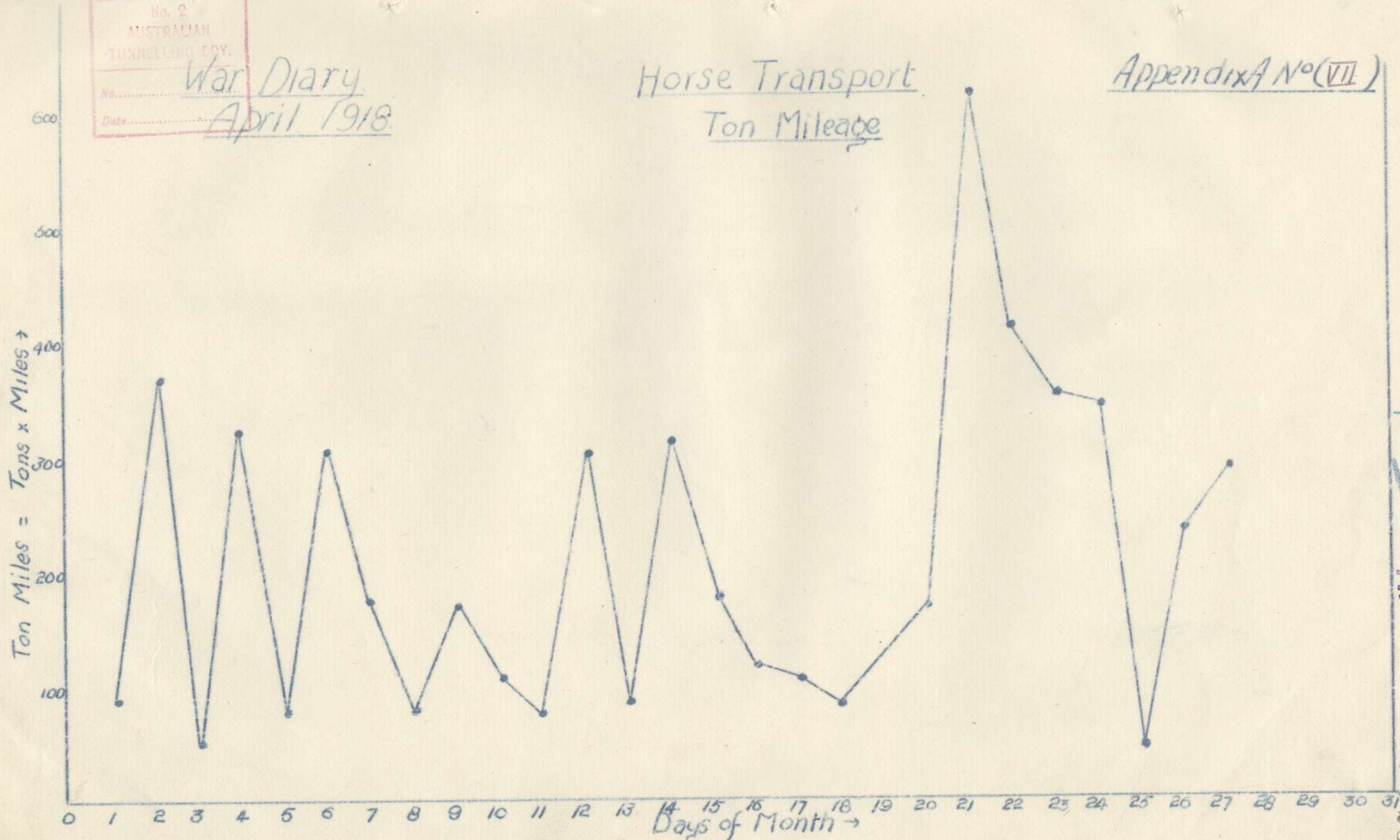

X Exhib

APPENDIX A
VII
28

No. 2
AUSTRALIAN
TUNNELLING COY.

No.
Date

CAR & LORRY REPORT

Week Ending -

War Diary
Appendix No. (VIII)
Part. 1.

No.	Maks	Driver and 2nd Driver	Where Situated	Condition	Consumption in gallons of Spirit	Mileage	Remarks
20855	Maudsley (Lorry)	Ward. J. Wvr.	Base	-	-	-	L/Cpl. Brown admitted to Hospital. 15-2-18. Wvr Gershon On leave 18-3-18.
20868	Maudsley (Lorry)	Smith. J. C. Wvr Bernard. V. "	H. Q.	Good	86	429	N ^o 20855. Lorry evacuated, crank case broken, Pistons & Piston rods broken, Differential broken. By 'O' Corps Supply Column 1-4-18
21908	Albion (Lorry)	Davis. J. E. Wvr. Kenny. W. "	H. Q.	Fair	100	497	N ^o 21928 Lorry sent to Workshops 1-4-18. 1 new tyre, 2 new flanges, 1 pair new Sprockets & Chains. Returned 5-4-18
21917	Albion (Lorry)	Anderson Wvr	Column Workshops		74	369	N ^o 21917 Lorry sent to Workshops, for engine repairs. 6-4-18
21928	Albion (Lorry)	Bray. W. J. Wvr. Grindley. J. "	H. Q.	Good	46	230	N ^o 21908 Lorry. Broken front spring & jamb iron
18889	Napier (Box Car)	Cooper. C. Wvr	H. Q.	Good	30	362	N ^o 18889. Box Car sent to workshops. 5-4-18 Radiator badly leaking - Returned 6-4-18
8924	Saurer (Lorry)	Woodliff. W. Wvr A.S.C. ATT.	H. Q.	Good	36	180	N ^o 8924. Lorry reported from 3 rd Army. 4-4-18.

X Ex Lmt

(Signed) J. C. Warren Corporal
1/4 Motor Transport

APPENDIX VIII

MILEAGE AND TONNAGE TABLE

Day	Date	Miles Travelled	Loads in Tons carried.	Tons	Miles	Remarks
	April					
Sunday	7	355	57	20,235		
Monday	1	271	42	11,382		
Tuesday	2	264	45	11,880		
Wednesday	3	243	39	10,477		
Thursday	4	314	45	14,130		
Friday	5	355	48	17,340		
Saturday	6	265	45	11,825		

Totals 2,067 321

General Remarks of Interest

Lorries have been used for conveying men and material, to and from their work. Practically the whole of their time has been used for this purpose.

No 2
 AUSTRALIAN
 TUNNELLING
 No.....
 Date.....

2nd Australian Tunnelling Coy.
Car and Lorry Report.
Week ending 14th April 1918.

Appendix No (VIII)
 Part 2

W.D No	Make	Driver	Where Situated	Condition	Consumption of spirit.	Mileage	Remarks
20855	Maudsley (Lorry)	Ward J. Warr.	Base.	-	-	-	L/Cpt. Brown. A.G. admitted to Hospital 15-2-18. Warr Gershon H. On leave from 18-3-18.
20880	Maudsley (Lorry)	Smith J. C. Warr. Bernard B. "	H.Q.	Good	74	374	Cl ^o 21908. Lorry fitted with one new Spring, & dumb iron, obtained from O'Corps, Siege Part.
21903	Albion (Lorry)	Warr J. C. Warr. Kenny W. "	H.Q.	Good	84	425	Cl ^o 21917 Lorry sent to Column Workshops (Aust Corps. M.T.) for engine repairs 12-4-18.
21917	Albion (Lorry)	Anderson W. Warr Fleming J. "	Column Workshops	-	44	220	Cl ^o 8924 Lorry, adjustments have been made, and lorry is in good running order, excepting, side brake out of order, water joints leaking, fan broken, & carburettor in bad condition
21908	Albion (Lorry)	Bray W. J. Warr Trindles J. "	H.Q.	Good	82	413	Cl ^o 9824. Lorry, one new Spring, & ignition adjustments also Petrol tank repairs
15289	Napier (Box Car)	Cooper C. W. Warr	H.Q.	Good	36	430	
8924	Saurer (Lorry)	Woodliff W. Warr A.S.C. F.H.	H.Q.	Good	70	359	(Signia) J.C. Warren, Corporal.

X Exhib

1/2 Peter T. - cont.

APPENDIX

Day	Date	No. of Travellers	Trucks in use	Total	Remarks
Sunday	14 th	255	36	9,186	
Monday	8	285	39	11,115	
Tuesday	9	335	51	17,085	
Wednesday	10	337	59	19,883	
Thursday	11	395	60	23,700	
Friday	12	349	45	15,705	
Saturday	13	265	42	11,110	
Total		2,221	332		

The work for Lorne during the post week was mainly the carrying of
 troops, material, and tools, to and from their work.

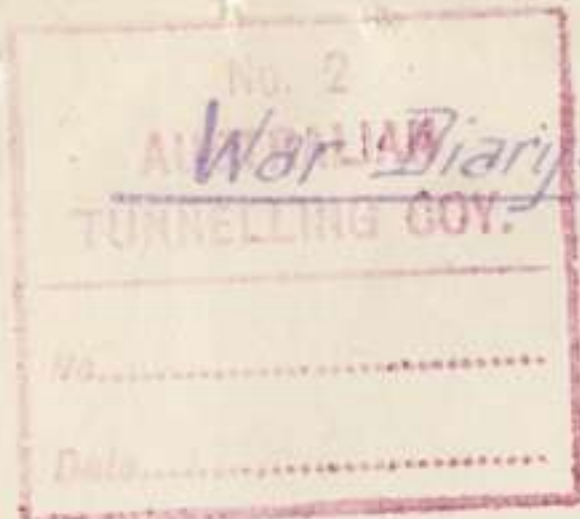

2nd Australian Tunnelling Coy.
Car and Lorry Report.
Week ending 21st April 1918.

Appendix No (VIII)
 Part 3

W. D. No	Make	Driver	Where Situated	Condition	Consumption of Spirit	Mileage	Remarks
8924 20855	Saurer Maudsley (Lorry)	Woodliff. W. Warr. Bernard. V. "	H.Q.	Good.	70.	355	L/Cpl Brown. A. G. Admitted to Hospital. - 15-2-18. Driver Ward. J. left with Lorry for Base. 1-4-18.
20868	Maudsley (Lorry)	Smith. J. C. Warr. Gershon. H. "	H.Q.	Good.	66	315.	№ 20868. Lorry. Super-structure broken, and body in bad condition, 2 wings off one front spring replaced by spares.
21908	Albion (Lorry)	Harris. C. C. Warr. Kenny. W. "	H.Q.	Good.	70.	347.	
21917	Albion (Lorry)	Anderson. W. Warr. Fleming. J. "	Cothman. workshops.				№ 21917. Lorry, left for Aust. Corps. M. G. Workshops, for repairs 12-4-18.
21928	Albion (Lorry)	Bray. W. J. Warr. Trindles. J. "	H.Q.	Good.	80.	405.	
18889	Napier (Box Car)	Cooper. C. W. Warr.	H.Q.	Good.	32.	380.	№ 18889. Box Car. Radiator leaking, and Brakes require attention.
25034							

X Exhib

(Signed) J. C. Warren. Corporal.
 1/c Motor Transport.

APPENDIX VIII
 33

Mileage and Tonnage Table.

Day	Date	Miles Travelled	Loads in Tons Carried	Tons Miles	Remarks
Sunday	21 st	240	30	11,200.	
Monday	15	325	51	16,575	
Tuesday	16	310	51	15,810	
Wednesday	17	232	33	7,656.	
Thursday	18	260	30	7,800.	
Friday	19	200	30	6,000	
Saturday	20	235	36	8,440	
Total.		1,802	261		

General Remarks of interest:

Work has again been very heavy for Lorries, the chief work being shifting troops, and supplying material

No. 2
WARRILBY
 TUNNELLING COY.
 No.
 Date

2nd Australian Tunnelling Coy.
Car and Lorry Report.
Week ending 28th April 1918.

Appendix No (VIII)
 Part 4

W.D. No	Make	Driver	Where Situated	Condition	Consumption of spirit.	Mileage	Remarks
8924 20855	Saurer Napier (Lorry)	Woodliff W. Warr. (A.S.C.) Ward J. Warr.	H.Q.	Fair	64	315	L/Cpl Brown A.G. Admitted to Hospital - 15-2-18 8924 Lorry. Span broken, side bratts out of order
20868	Napier (Lorry)	Smith J.B. Warr. Gershon H. "	H.Q.	Good	76	365	20868 Lorry, Brattes require lining, Superstructure broken.
21908	Albion (Lorry)	Davis E.E. Warr. Bernard W. "	H.Q.	Good	74	370	
21917	Albion (Lorry)	Anderson W. Warr. Trendles J. "	Column Workshops				21917 Lorry At Column Workshops, undergoing repairs; from 12-4-18.
21928	Albion (Lorry)	Gray W. J. Warr. Kenny W. "	H.Q.	Good	80	405	
18889	Napier (Box Car)	Cooper C. W. Warr.	H.Q.	Good	32	385	18889 Box Car. Radiator leaking, Brattes require lining

X Taken

(Signed) J.C. Warren. Corporal.
 1/2 Miles to report.

APPENDIX A
 III
 35

Mileage and Tonnage Table.

Day	Date April.	Miles Travelled	Loads in Tons Carried	Tons Miles	Remarks
Sunday.	28	225	39	8,775	
Monday	22	295	45	13,275	
Tuesday	23	295	42	12,390	
Wednesday	24	310	36	11,160	
Thursday.	25	140	24	3,360	
Friday.	26	275	45	12,375	
Saturday.	27	300	38	11,400	
Total.		1840.	269		

General Remarks of interest:

The Company being scattered over such a large area, means very heavy work for the Lories, in supplying them with material, and carrying them to and from the different places.

No. 2
AUSTRALIAN
TUNNELS
War Diary
No.
Date

Motor Transport.
Ton-Mileage.

April: 1918.
Appendix A No (IX)

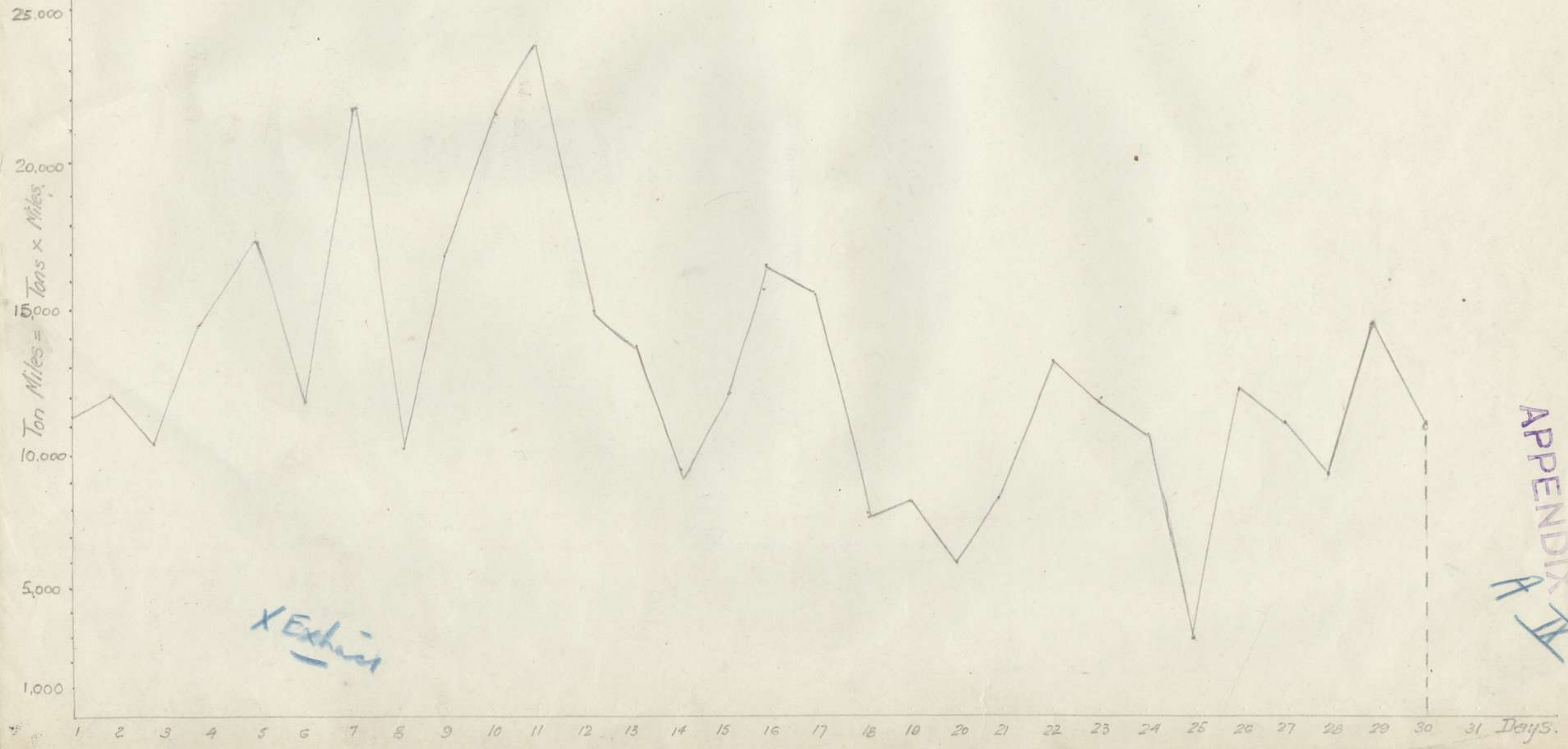

X Exhaust

APPENDIX
A IX

No. 2
 AUSTRALIAN
 TUNNELLING COY.
 No.....
 Date.....

2nd Australian Tunnelling Coy.

WEEKLY MOTOR CYCLE REPORT

War Diary
 Appendix N^o (X)
 Part. 1.

Week Ending April 6th 1918.

No.	Sec.	Make	Ridden by	Located at	Defects and Remarks.
1	Head Quarters	Douglas S.C.G.		Head. Quarters	Running Order
2		Douglas	Capt. G.I. Adcock	H. Q.	Do
3		Douglas	Capt. Brookes	H. Q.	Do
1	No. 1	Triumph	Capt de Grot	Army	Sgt Jarry. D. R. at Army
2		Douglas	Subalterns	H. Q.	Running Order
3	No. 2	Douglas	Capt. Smith	- -	Lost
4		Triumph	Subalterns	Army	Sap Bennetts. D. R.
5	No. 3	Douglas	Dispatch	H. Q.	Running order
6		Douglas	Subalterns	Army	Sap L. Hill
7	No. 4	Triumph	Capt. Cohen	- -	Lost on road from Aveluy
8		Triumph	Subalterns	H. Q.	Sent to Column (big end & new gudgeon repairs)
Attached		Douglas	Lieut. Reid	- -	Returned to C.R.E. 5 th Corps.
100	A1.	Douglas	170	- -	Lost on road by C.R.E. 2 nd Div
102		Douglas	170	H. Q.	Running order

(Signed) Sap. T.F. Smith 1/c

APPENDIX
 AA

No. 2
 AUSTRALIAN
 TUNNELING COY.
 No.....
 Date.....

2nd Australian Tunneling Coy.

WEEKLY MOTOR CYCLE REPORT

War Diary
 Appendix N°(X)
 Part. 2.

Week ending April 13th 1918

No.	Sec.	Make	Ridden by	Located at.	Defects and Remarks.
1 ^a	Head	Douglas S.S.C.		Head Quarters	Extra Side Car received-12-4-18 (3203-3697)
1		Douglas S.C.C.		Head Quarters	" " (3164X-3832)
2	Quarters	Douglas	Capt. G.I. Pitcock	(H.A.A.) Lieut Cook	Running Order (35622-36379)
3		Douglas	Capt. Brookes	H. Q	Do (22927-23023)
1	No. 1	Triumph	Capt de Groot	Army	Do (48141-27563)
2		Douglas	Subaltern	H. Q	Do (34330-34647)
3	No. 2	Douglas	Capt. Smith	Lost	- -
4		Triumph	Subaltern	Army	Running Order (41502-266104)
5	No. 3	Douglas	Dispatch	H. Q	Do (31267-31019)
6		Douglas	Subaltern	Army	Do (34542-34758)
7	No. 4	Triumph	Capt. Cohen	Lost	- -
8		Triumph	Subaltern	Column	- -
Attached		Douglas	Lieut. Reid	Returned to C.R.E.	- -
100	A.1	Douglas	178 Coy. R.E.	Lost	- -
101	A.2	Douglas	Officers	H. Q	Running Order (30442-30129)

(Signed) Sap T.F. Smith 1/c. 39

APPENDIX
 AA

No. 2
 AUSTRALIAN
 TUNNELLING COY.
 No.....
 Date.....

Emp. Australian Tunnelling Coy.

WEEKLY MOTOR CYCLE REPORT

War Diary
 Appendix No (X)
 Part. 3.

Week Ending 20th April 1918

No.	Sec.	Make	Ridden by	Located at	Defects and Remarks.
1a	Head	Douglas S.C.C.	Capt Adcock	H.Q.	Good running order.
1		Douglas S.C.C.	Lieut Cook	H.Q.	Under repairs, going to Column.
2	Quarters	Douglas	Capt G. Adcock		Good running order.
3		Douglas	Capt. Brookes	H.Q.	" " " "
1		No. 1.	Triumph	Capt de Grut.	H.Q.
2	No. 2	Douglas	Subalterns	H.Q.	" " " "
3		Douglas	Capt. Smith	H.Q.	Douglas drawn 18-4-18. N ^o 33341, to replace lost No. 3
4		Triumph	Subalterns	Army	Ridden by Sap. E. Bennett
5	No. 3	Douglas	Dispatch	H.Q.	Running order.
6	No. 4.	Douglas	Subalterns	Army	Ridden by Sap. L. Heill
6		Triumph	Capt Phippard	H.Q.	N ^o 262149, drawn from Column 18-4-18.
7		Triumph	Capt Cohen		
8		Triumph	Subalterns	Amiens	Ridden by Capt Cohen
Attached		Douglas	Lieut. Reid		
00. A1.		Douglas	179 Coy. R.F.		
00. A2.		Douglas	Officers	ATTN Officers	Running order (Signed) Sap. J. J. Smith 1/c

APPENDIX
 AA
 40

WEEKLY MOTOR CYCLE REPORT

Appendix No. (X)

Week ending April 27th 1918.

No.	Sec.	Make	Ridden by	Located at	Defects and Remarks.
1a	Head-Quarters	D. Side Car	Sab. Mulligan	H.Q.	Running order.
1		D. Side Car	Major Mulligan	H.Q.	No. (Car repaired at Colimint)
2	Head-Quarters		Capt. G. H. Adcock	H.Q. ^{C.H.A.} Battery	Ridden by Lieut. Poole
3		Douglas	Capt. Brookes	Colimint	undergoing repairs
1	No. 1.	Triumph	Capt. de Grut.	H.Q.	Running order.
2		Douglas	Subalterns.	H.Q.	No.
3	No. 2	Douglas	Capt. Smith	H.Q.	No.
4		Triumph	Subalterns.	Army	No.
5	No. 3.		Capt. Phippard.	H.Q.	No.
6		Douglas	Subalterns.	H.Q.	Returned from Army 25-4-18
7	No. 4.	Triumph	Capt. Cohen.	H.Q.	Running order.
8		Triumph	Subalterns.	H.Q.	No.
Attached.		Douglas	Lieut. Reid.		

(Signed) Cap. J. H. Smith /c.

APPENDIX A

"A" Form.
MESSAGES AND SIGNALS.

Army Form C.2121
(In pads of 100).
No. of Message _____

Prefix.....	Code.....	m.	Words	Charge	This message is on a/c of:	Recd. at.....
Office of Origin and Service Instructions.						Service.
			Sent			Date.....
			At.....			From.....
			To.....			By.....
			By.....		(Signature of "Franking Officer.")	

TO { 2nd Australian Tunnelling Coy.

Sender's Number.	Day of Month.	In reply to Number.	AAA
* AC 55	4		

2 Officers 30 OR. with tools and stores for bridge demolitions to report as early as possible today to Capt. GIBSON I.W.T. at AMIENS Lock Office aaa. Draw necessary stores from QUERRIEU dump and dispatch party by torry at once aaa. Men must be withdrawn if necessary from work now in hand.

From C.E. VII Corps
Place
Time

The above may be forwarded as now corrected. (Z) *[Signature]*
Censor. Signature of Addressor or person authorised to telegraph in his name.

* This line should be erased if not required.
750,000. W 2121-M509. H. W. & V., Ld. 6/15.

"A" Form.
MESSAGES AND SIGNALS.

Army Form C. 2121.
(In pads of 100.)
No. of Message _____

Prefix.....	Code.....	m.	Words	Charge	This message is on a/c of:	Recd. at.....
Office of Origin and Service Instructions.						Service.
			Sent			Date.....
			At.....			From.....
			To.....			By.....
			By.....		(Signature of "Franking Officer.")	

TO { 2nd Austⁿ Tunnelling Coy.

Sender's Number.	Day of Month.	In reply to Number.	AAA
* AC 55	6		

Hold in readiness 3 Officers 100 OR for bridge demolitions at AMIENS aaa. An officer who accompanied party detailed in my AC 55 of 4th inst. should be included aaa. Tools must be taken and party will stand by until receipt of further orders aaa Acknowledge aaa.

Rept'd C.E. Austⁿ Corps.

From C.E. VII Corps
Place
Time

The above may be forwarded as now corrected. (Z) *[Signature]*
Censor. Signature of Addressor or person authorised to telegraph in his name.

* This line should be erased if not required.
(3198.) Wt. W 12952/M1294. 375,000 Pads. 1/17. H. W. & V., Ld. (E. 818.)

APPENDIX
A VII

APPENDIX

XI

11
12
13
14
15
16
17
18
19
20
21
22
23
24
25
26
27
28
29
30
31
32
33
34
35
36
37
38
39
40
41
42
43
44
45
46
47
48
49
50
51
52
53
54
55
56
57
58
59
60
61
62
63
64
65
66
67
68
69
70
71
72
73
74
75
76
77
78
79
80
81
82
83
84
85
86
87
88
89
90
91
92
93
94
95
96
97
98
99
100

11
12
13
14
15
16
17
18
19
20
21
22
23
24
25
26
27
28
29
30
31
32
33
34
35
36
37
38
39
40
41
42
43
44
45
46
47
48
49
50
51
52
53
54
55
56
57
58
59
60
61
62
63
64
65
66
67
68
69
70
71
72
73
74
75
76
77
78
79
80
81
82
83
84
85
86
87
88
89
90
91
92
93
94
95
96
97
98
99
100

11
12
13
14
15
16
17
18
19
20
21
22
23
24
25
26
27
28
29
30
31
32
33
34
35
36
37
38
39
40
41
42
43
44
45
46
47
48
49
50
51
52
53
54
55
56
57
58
59
60
61
62
63
64
65
66
67
68
69
70
71
72
73
74
75
76
77
78
79
80
81
82
83
84
85
86
87
88
89
90
91
92
93
94
95
96
97
98
99
100

MESSAGES AND SIGNALS.

No. of Message

Prefix.....Code.....m. Words Charge
 Office of Origin and Service Instructions. This message is on a/c of: Recd. at.....m.
 Special DR. Sent Service. Date.....
 At.....m. From.....
 To..... By.....
 (Signature of "Franking Officer.")

TO { 2nd Aust Tunn Coy ✓
 CE 3rd Army
 CE 4th Army

Sender's Number. Day of Month In reply to Number
 * D5329 7 A A A

Reference AC 57 of CE 7th
 Corps of 6th aaa 3
 Officers and 100 OR now
 held in readiness will immediately
 proceed to AMIENS and prepare
 for demolition the road bridges
 already detailed aaa The charges
 are not to be laid but
 all other preparations will be
 finished aaa When this work
 is completed you will advise
 CE 4th Army and this office
 by wire and instruct party
 to stand by until receipt
 of further orders/aaa Acknowledge aaa
 Addd 2nd Aust Tunn Coy reptd CE
 3rd Army reptd CE 4th Army

From
 Place CE Aust Corps
 Time

The above may be forwarded as now corrected.

(Z) CP Sheldom Capt RE

Censor. Signature of Addressor or person authorised to telegraph in his name.

* This line should be erased if not required.

MESSAGES AND SIGNALS.

No. of Message

Prefix.....Code.....m. Words Charge
 Office of Origin and Service Instructions. This message is on a/c of: Recd. at.....m.
 Sent Service. Date.....
 At.....m. From.....
 To..... By.....
 (Signature of "Franking Officer.")

TO { 2nd Aust Tunn Coy
 CE
 CE

Sender's Number. Day of Month In reply to Number
 * D5350 7 A A A

Arrange to forward to CE
 4th Army aaa sketches and
 details of all bridges in AMIENS
 which you have prepared for
 demolition

From
 Place CE Aust Corps
 Time

The above may be forwarded as now corrected.

(Z) CP Sheldom Capt RE

Censor. Signature of Addressor or person authorised to telegraph in his name.

* This line should be erased if not required.

APPENDIX A II

APPENDIX A

XI

XI

COPIES OF LETTERS AND TELEGRAMS
AMIENS DEMOLITION WORK.

APPENDIX A 44
APRIL 1918.
APPENDIX A No. (XLI)

Controller of Mines,
Third Army.

C.E. Third Army No. 3 219/s/108.

Please proceed at once to AMIENS and prepare all road bridges over the Somme and channels for demolition.

No charges to be placed in position but all preparations to be made for rapid demolition. Explosives are being sent to the I.W.T. office at AMIENS Lock.

2 Officers and 30 O.Rs of the 2nd Australian Tunnelling Coy will report as soon as possible to you at the I.W.T. office AMIENS Lock.

In the meantime proceed with the work using the I.W.T. or any other labour available.

The Town Major, AMIENS might be able to assist you in this matter.

Report to be sent into this office as soon as a bridge is prepared giving location.

(Signed) G.C.S. Streatfield. Capt.
for Major General.
Chief Engineer, Third Army.

4/4/18.

(Copy)

General Staff, Third Army. (for information)

Capt. Gibson. I.W.T. AMIENS LOCK.

O.C. Detachment 2nd Australian Tunnelling Coy. c/o Capt Gibson. I.W.T.

AMIENS LOCK, copy for information. To be handed him on arrival.

Capt. Gibson will proceed with the work pending the arrival of Major Laws.

To 2nd Australian Tunnelling Coy. A.C. 55.
2 Officers 30 O.Rs with tools and stores for bridge demolition to report as early as possible today to Capt. GIBSON. I.W.T. at AMIENS lock office
Draw necessary stores from QUERRIEU dump and dispatch party by lorry at once. Men must be withdrawn if necessary from work now in hand.

4/4/18.

From C.E. V11th Corps.

To 2nd Australian Tunnelling Coy. A.C. 57
Hold in readiness 3 officers 100 O.Rs for bridge demolition at AMIENS.
An officer who accompanied party detailed in my A.C.55 of 4th inst should be included. Tools must be taken and party will stand by until receipt of further orders. Acknowledge.
(Repeated C.E.Aust. Corps.)

6/4/18.

From C.E. V11th. Corps.

To 2nd Australian Tunnelling Co.
C.E. 3rd Army.
C.E. 4th Army.

D 5329. Special D.R.

Reference A C 57 of C.E. 7th Corps of 8th. 3 officers and 100 O.Rs now held in readiness will immediately proceed to AMIENS and prepare for demolition the road bridges already detailed. The charges are not to be laid, but all other preparations will be finished. When this work is completed you will advise C.E. 4th Army and this office by wire and instruct party to stand by until receipt of further orders. Acknowledge.

7/4/18.

From C.E. Aust. Corps.

To 2nd Australian Tunnelling Co. D 5350.
Arrange to forward to C.E. 4th Army Sketches and details of all bridges in Amiens which you have prepared for demolition.

7/4/18.

From C.E. Aust. Corps.

To Adjutant, 2nd A.T.Co.

The O.C. has full particulars of bridges being prepared for demolition --

Boulevard la Beauville.	2 bridges.
# Baraban.	1 bridge.
Rue Saint Leu.	1 "
Boulevard du Jardin des Plantes.	1 "
Rue du Chateau Milan.	1 "
Pont St Michael.	1 ,

All these bridge the Somme with the exce ption of one of the first and the last.

(Signed). A.F.Cohen. Capt.
O.C. Detachment. 2nd A.T.CO.

10/4/18.

C.E. 4th Army.

The following bridges are being prepared for demolition in AMIENS:

Boulevard de Beau Ville.	2 bridges.
Boulevard Baraban.	1 Bridge.
Rue Saint Leu.	1 "
Boulevard du Jardin des Plantes.	1 "
Rue du Chateau Milan.	1 "
Pont St Micheal.	1 "

(Signed) E.N.MULLIGAN. Major.
O.C. 2nd Australian Tunnelling Coy.

10/4/18.

To 2nd Australian Tunnelling Coy.

P 28.

100 men of 63rd Labour Group will be placed at your disposal for work on the 18th inst. Get into touch with Headquarters of group and fix all details, Have not made arrangements for transporting party to AMIENS as no lorries are available.

17/4/18.

From C.E. Aust. Corps.

To 2nd Australian Tunnelling Co.

P 78.

Meet O.C. 172 Tunnelling Coy. R.E. at 9 a.m. 22nd at 62d/ M 7 b 3.7. To hand over AMIENS bridges. Handing over to be completed by noon. Wire C.E. 3rd Corps direct the number of officers N.C.Os and men employed guarding these bridges.

From C.E. Aust. Corps.

21/4/18.

No. 2
AUSTRALIAN TUNNELLING COY.
AUSTRALIAN CORPS.

Engineer Instructions No. 90. ... 10th April 1918.

To be communicated only to Officers of Units concerned.

1. In the event of it becoming necessary to withdraw the Units working on Roads and Defence Works, the following steps will be taken.
2. One officer of 180 Tunnelling Company R.E. and one of the 2nd Australian Tunnelling Coy. A.E. each with a motor bicycle, will be stationed at Headquarters, Corps Heavy Artillery, in Montigny, from 6 a.m. on 11/4/1918.
3. In the event of a withdrawal being ordered, a telegram will be sent by C.E to these officers, reading as follows;

"(No) (Date) Withdraw Engineer working parties.
(Signature).
4. On receipt of this wire, the Officers will proceed by motor bicycle as follows. The officer of 180 Tunnelling Company R.E. via QUERRIEU, La Houssoye, Franvillers, Baizieux, Behencourt, back to Montigny.
The officer of the 2nd Australian Tunnelling Coy A.E. via Baizieux, Fransvillers, La Houssoye, Querrieup back to Montigny.
Each officer will warn all the Engineer and Pioneer Units employed under C.E. at these places to withdraw.
5. On receipt of this order, Units concerned will move to PIERREGOT where they will park clear of roads and await orders, C.E. to be informed as soon as practicable of the arrival of a Unit at Pierregot.
6. Before leaving, any material which cannot be saved, and which the troops engaged on local defence cannot use, will be destroyed.
7. Unit commanders will arrange for a careful reconnaissance of the routes to be used to Pierregot, and of the space for parking there, at once.
8. The following are the Units to be warned:

Unit	Location.	Map reference.
177 Tunnlg Coy R.E.	Baizieux.	
178 Tunnlg Coy R.E.	Bussy.	
180 Tunnlg Coy R.E.	Querrieu.	
2nd Australian Tunnelling Co	QUERRIEU.	
238 A.T. Company. R.E.	Querrieu.	
4th Army Workshops Coy.	St Gratien.	
Aust Corps Workshops Coy.	Querrieu.	
4th Field Coy. A.E.		C 6 a 1.4.
125th Field Coy. A.E.	La Houssoye.	I 3 c.
13th Field Coy. A.E.	Allonville.	
4th Pioneer Batt ln.	La Houssoye.	I 3 c.

9. ACKNOWLEDGE.

Signed C.H. FOOTT.
Brigadier General.
Chief Engineer, Australian Corps.

X Extract

Prefix..... Code.....m. Office of Origin and Service Instructions. Words Charge. This message is on a/c of: Recd. at.....m. Sent Service. Date. At.....m. From..... To..... By..... (Signature of "Franking Officer.")

TO { Querrien RE Dump }

* Sender's Number D5508 Day of Month In reply to Number AAA

Issue to 238 A.T. Coy RE
 2nd Aust Infantry Coy RE each 1/5 up
 to 1/5 stock of explosives at Querrien
 Indents for large amounts will
 be referred to this office in the usual

All members
 Stores Officer Capt RE
 1st Aust Corps
 14/4/18
 Capt RE
 238 A.T. Coy RE
 2nd Aust Tunnng Coy RE

From Place Time

The above may be forwarded as now corrected. (Z) Signature of Addressor or person authorised to telegraph in his name. Censor.

• This line should be erased if not required. (A1) O. Ltd., London— W.14042/M.44. 150,000 Pads. 12/15. Form C.3121.

Prefix..... Code.....m. Office of Origin and Service Instructions. Words Charge. This message is on a/c of: Recd. at.....m. Sent Service. Date. At.....m. From..... To..... By..... (Signature of "Franking Officer.")

TO { 2nd Aust Tunnng Coy RE ✓
178 Tunnng Coy RE }

* Sender's Number P609 Day of Month 11 In reply to Number AAA

You will arrange to
 take over at once
 responsibility for guarding and
 demolition of bridges in
 DROURS and LA NEUVILLE
 now controlled by 178
 Tunnng Coy RE and you
 will detail an officer
 to immediately report to
 HQ 178 Tunnng Coy at BUSSY H.35.082
 as a treat as urgent as 178 Tunnng Coy
 are moving tonight
 Address 2nd Aust Tunnng Coy RE
 178 Tunnng Coy RE

D5569 From CE Place Aust Corps Time

The above may be forwarded as now corrected. (Z) Signature of Addressor or person authorised to telegraph in his name. Censor.

• This line should be erased if not required. (7981) Wt. W492/M1647 130,000 Pads 5/17 D. D. & L. E1187 Capt RE

APPENDIX A13 47

MESSAGES AND SIGNALS.

Prefix *Am* Code *KEP* Words *57* No. of Message
 Received. Sent, or sent out. Office Stamp.
 From *AMO* At *11.11.13*
 By *P. Knight* To
 By
 Charges to Collect
 Service Instructions
 Handed in at *AMO* Office *12.20* m. Received *10.50* m.

TO *2nd Aust Gunns Coy*

*Sender's Number.	Day of Month.	In reply to Number.	AAA
<i>P 11</i>	<i>16th</i>	<i>✓</i>	<i>AAA</i>
<i>Arrange to</i>	<i>to</i>	<i>get</i>	<i>me</i>
<i>to</i>	<i>touch</i>	<i>with</i>	<i>BE</i>
<i>3rd</i>	<i>Aust</i>	<i>Div's</i>	<i>reference</i>
<i>taking</i>	<i>over</i>	<i>bridges</i>	<i>AAA</i>
<i>BE</i>	<i>3rd</i>	<i>Aust</i>	<i>Div's</i>
<i>would</i>	<i>like</i>	<i>you</i>	<i>to</i>
<i>call</i>	<i>at</i>	<i>STRATIEN on</i>	
<i>morning</i>	<i>of</i>	<i>14th</i>	<i>aaa</i>
<i>addsd</i>	<i>2</i>	<i>Aust</i>	<i>gunns</i>
<i>boy</i>	<i>Rpt</i>	<i>BE</i>	<i>3rd</i>
<i>Aust</i>	<i>Div's</i>		

FROM *BE Aust boat*
 TIME & PLACE

*This line should be erased if not required.

MESSAGES AND SIGNALS.

Prefix *Am* Code *HAW* Words *45* No. of Message
 Received. Sent, or sent out. Office Stamp.
 From *AMO* At
 By *Sykes* To
 By
 Charges to Collect
 Service Instructions
 Handed in at *AMO* Office *8.8* m. Received *8.8* m.

TO *2nd Aust Gunns Coy*

*Sender's Number.	Day of Month.	In reply to Number.	AAA
<i>P 689</i>	<i>16</i>		<i>AAA</i>

You will arrange to
take the responsibility for
guarding and demolition of
bridge at LA MOTTE
from 6th US engineers
aaa added 2nd
Gunns Coy repts
US Engineers repts
Aust Coy 6

FROM *68 Aust Coy*
 PLACE & TIME

*This line should be erased if not required.

APPENDIX A.13.

APPENDIX A.1

X 911

X 911



APPENDIX A.13
April 1918 49
Appendix A (No XIII).

C. E.
Aust. Corps.

In accordance with your wire P.689 dated 16/4/18 an officer and party reported at K. Bridge, La Motte to take over from the 6th U. S. Engineers.

He found that this bridge was being guarded by the 172 Tunnelling Coy, R.E.

The O.C. of this Company stated that his orders were to guard and demolish this bridge.

Under the circumstances we did not take over the bridge, and I will await further instructions from you.

Major, O.C.
2nd Australian Tunnelling Coy.

17/4/18.

WAR LIBRARY
AUSTRALIAN
TRAVELLERS COY
No.
Date

From
To
Date
No. XIII

APPENDIX A. 13
April 1918
Appendix A (No XIII).
49

APPENDIX A.13

Capt. G. L. Smith,
2nd Australian Tunnelling Coy.

You will take over the guarding and responsibility for demolition of Bridge K. at La Motte, from the 6th U. S. Engineers.

After reconnoitring and finding out the number of men required you will take ~~xxxx~~ them from Captain Cohen's detachment in Amiens, and move them to La Motte.

Major, O.C.
2nd Australian Tunnelling Coy.

16/4/18.





XIII

APPENDIX A.13

WAR DIARY.

APRIL. 1918.

COPIES OF LETTERS AND TELEGRAMS.
DEMOLITION WORK.

APPENDIX A No. (X11)
Part. 1.

To 2nd Australian Tunnelling Coy.

Special D.R. P 609.

You will arrange to take over responsibility for guarding and demolition of bridges in DAOURS and LA NEUVILLE now controlled by 178 Tun. Coy. R.E.aaa You will detail an officer to immediately report to H.Q. 178 Tun. Coy. R.E. at BUSSY H 35 c 8.2.aaa Treat as urgent as 178 Tun.Coy. are moving tonightaaa. Addsd 2nd Aust.Tun .Coy. R.E. Reptd 178 Tun. Coy. R.E.

11/4/18.

(Signed). C.E. Aust Corps.

To QUERRIEU DUMP.

D 5808.

Issue to 338 A.T.Coy R.E. and 2nd Aust. Tunnlg Coy. A.E. each up to 1/5th of stock of explosives at Querrieu. Indents for large amounts will be rendered to this office in the usual way.

14/4/18.

(Signed) A.M.Greenless CAPT. A.E.
Stores officer for C.E.
Aust Corps.

To 2nd Australian Tunnelling Co.

P 11.

Arrange to get in touch with C.R.E 3rd Aust. Divn reference taking over bridges aaa C.R.E. 3rd Aust. Divn would like you to call at ST GRATIEN on morning of 17th aaa Addsd 2nd Aust Tunn Coy. Rpt C.R.E. 3rd Aust Divn.

16/4/18.

(Signed). C.E. Aust. Corps.

To 2nd Australian Tunnelling Coy.

P 689

You will arrange to take the responsibility for guarding and demolition of bridge K at LA MOTTE from 6th U.S Engineers aaa Addsd 2nd Aust. Tun. Coy. reptd 6th U.S. Engineers reptd G Aust Corps.

16/4/18.

(Signed). C.E. Aust. Corps.

Capt. G.L. Smith.

2nd Australian Tunnelling Coy.

You will take over the guarding and responsibility for demolition of Bridge K. at La Motte, from the 6th U.S. Engineers.

After reconnoitring and finding out number of men required you will take them from Captain Cohen's detachment in AMIENS, and move them to La Motte.

16/4/18.

(Signed). E.N.MULLIGAN. Major. O.C.
2nd Australian Tunnelling Coy.

C. E.

Aust. Corps.

IN accordance with your wire P 689 dated 16/4/18 an officer and party reported at K bridge, La Motte to take over from the 6th U.S. Engineers.

He found that this bridge was being guarded by the 172 Tun. Coy. The O.C of this company stated that his orders were to guard and demolish this bridge.

Under the circumstances we did not take over the bridge, and I will wait further instructions from you.

17/4/18.

(Signed). E.N.MULLIGAN. Major. O.C.
2nd Australian Tunnelling Coy.

Controller of Mines,
4th Army.

The work of this Company is as follows:-

- 1.- The guarding and demolition of 31 bridges in the Australian Corps Area.
- 2.- The guarding and preparing for demolition of 10 bridges in Amiens.
- 3.- The putting in of the Defence Line from DAOURS to RIBEMONT

ATTACHED LABOUR - 5thrd Labour group less one company.

493
19/4/18

Major, O.C.
2nd Australian Tunnelling Coy.



APPENDIX A.13.

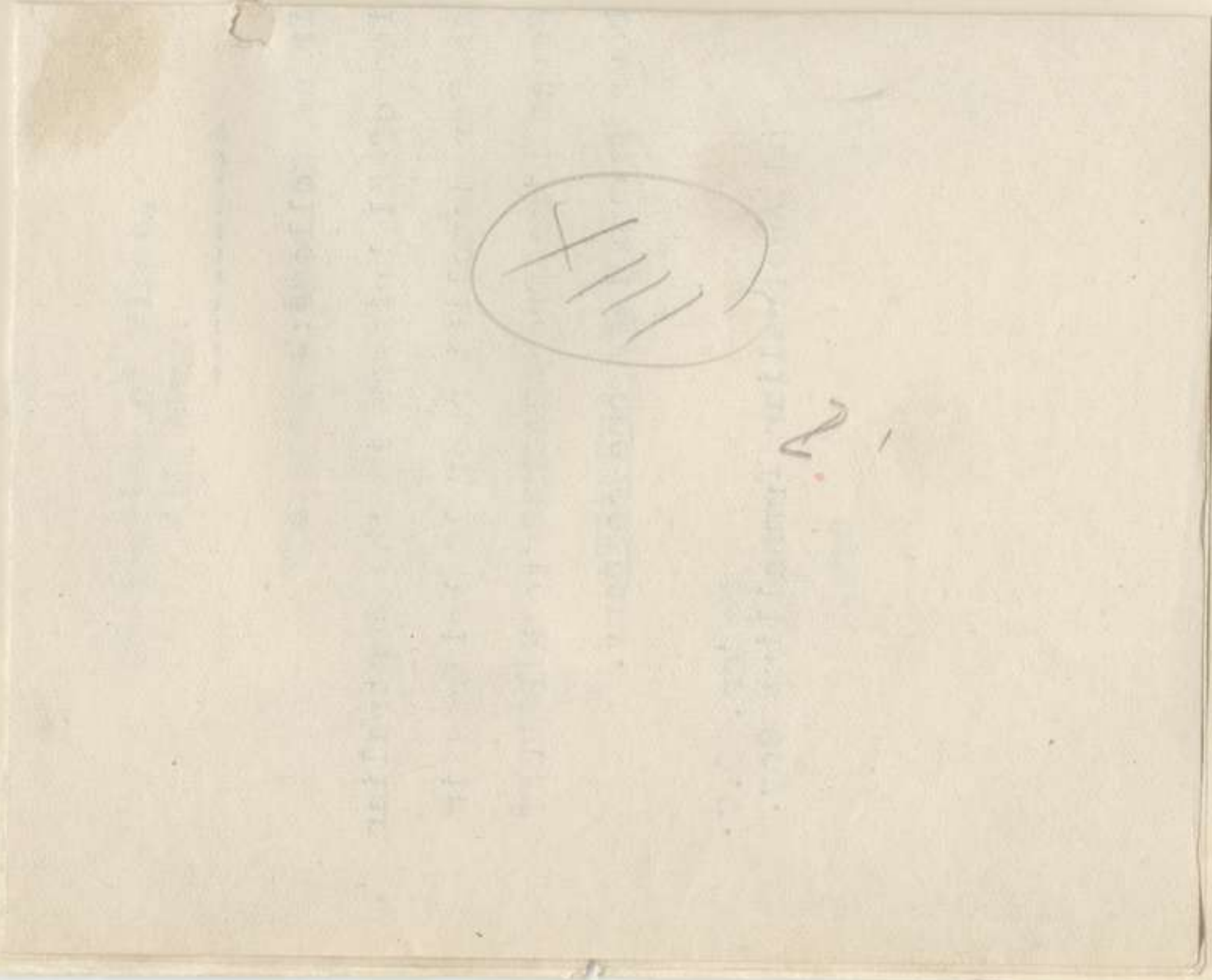



APPENDIX A.13

Appendix A. No. XIII 53
Part 2.

C. E.
Australian Corps.

In accordance with the second amendment to Instructions for the Defensive No. 10, officers and O. R. reported to take over the additional bridges detailed in Group No. 4 of the 2nd Australian Tunnelling Coy Demolition Instructions No. 2, less Nos. 11, 12, 13 and 14, as set out in your wire P. 74 dated March 20th.

The officer in charge of the 2nd Australian Tunnelling Coy. detachment found that the bridges which we were to take over, had been handed over today by the 254th Tunnelling Coy. R. E. to the Pioneers of the 5th Australian Division.

No orders had been received to hand over to us, and under the circumstances we have not taken over the bridges.

I will await your instructions.

E. V. Mullen Major, O.C.
2nd Australian Tunnelling Coy.

501
21/4/18.

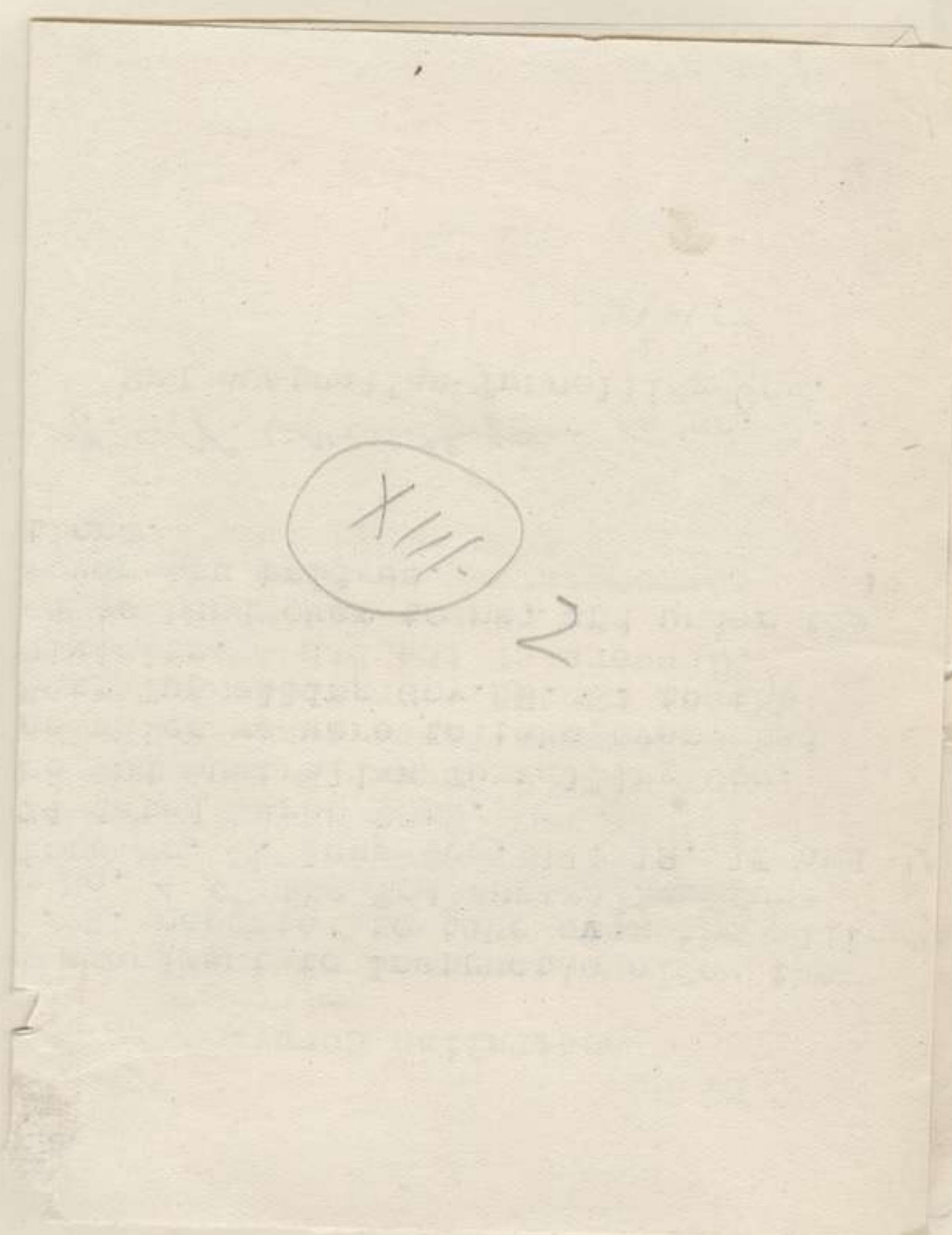

No 2
AUSTRALIAN
TUNNELING COY
No.
Date

APPENDIX A.13
Appendix A. No XIII 53
Part 2.

2. 11. 18



C.E. Australian Corps. *285/416/r*

21st. April 1918.

O i/c Querrieu RE Dump.

All mining sets at Querrieu RE Dump are to be issued to the 180 Tunnelling Company RE and all Beech slabs to 2nd. Australian Tunnelling Company. No issues of these two items are to be made to any other units without special authority. Previous instructions are cancelled.

AE

Captain AE
Stores Officer for CE Australian Corps.

Copy to/

O.C. 180 Tunnelling Coy RE.
2nd. Australian Tunnelling Coy AE.

[Handwritten signature]

[Circular stamp with handwritten initials 'AE']

D90





XIII 2

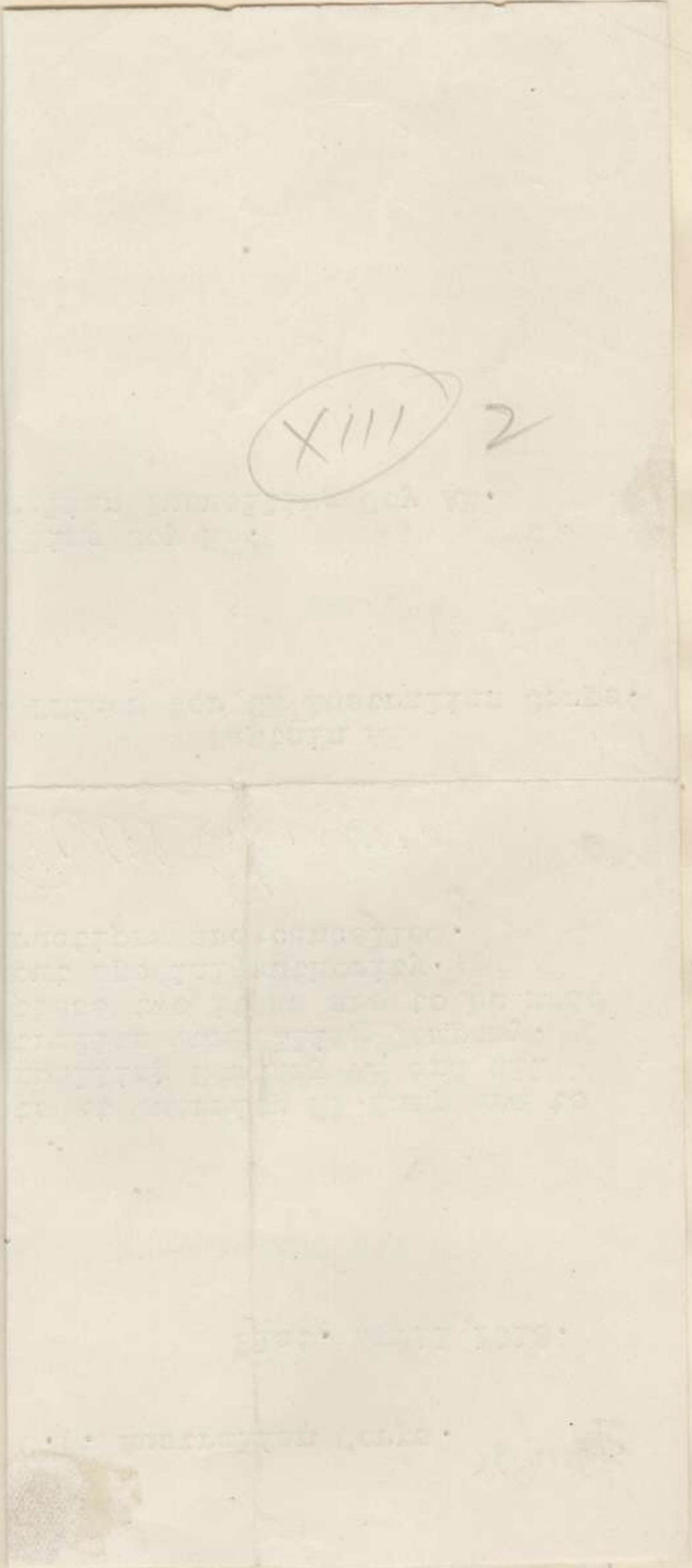

APPENDIX A.13

2.4.18C.E. Australian Corps.
No. 125/

19th. April 1918.

O i/c Guerrieu RE Dump.

50% of the mining sets received at the dump are to be issued each to the 2nd. Australian Tunnelling Coy, and 180 Tunnelling Company R.E. No other units are to be issued with mining sets.

Beech slabs are only to be issued on authority from this Office.

Captain A.E.

Stores Officer for CE Australian Corps.

Copy to:

2nd. Australian Tunnelling Company A.E.
180 Tunnelling Company R.E.

81

4





[Faint, illegible text from a document pasted onto the page. The text is mirrored and difficult to decipher.]

XIII

2

APPENDIX

A.13.

55

Copies of letters and telegrams.

DEMOLITION WORK (contd).

Telegram to C.E. Australian Corps.

Senders No. P 235.

The following bridges are ready to be prepared for demolition N 6 d 7.5. aaa 0 5 c 5.5. aaa 0 5 c 5.8. aaa. Spare girders near sites for following bridges 0 7 b 1.9. aaa 0 5 c 3.0. aaa One of my officers will be at 0 5 c 5.5. all day tomorrow.

19/4/18.

From 574 A.T. Coy. R.E.

C.E. Australian Corps.
20/4/18.

O.C. 2nd Australian Tunnelling Coy.

All bridges under your charge and prepared for demolition are to have a notice board affixed to them, having painted on it the serial number of the bridge as set out in revised tables of Instructions for the Defensive No. 10.

Order to draw these numbered boards from QUERRIEU R.E. Dump is attached.

(Signed) John. G. Burnell. Cap. A.E.
for C.E. Aust. Corps.

Controller of Mines.
4th Army.

WORK FOR WEEK ENDING 24/4/18.

1. - Ancre Ribemont Defence Line.
ATTACHED LABOUR - 53rd Labour Group, less 1 company.
2. Guarding and preparing for demolition the bridges as detailed in Demolition Instructions No. 2 less No. 3 Group - which has been handed over to 172 Tunnelling Coy. R.E. and bridges 11, 12, 13, 14 of group No. 4, for which 3rd Corps are now responsible.

(Signed) E.N. MULLIGAN. Major. O.C.
2nd Australian Tunnelling Coy.

511
25/4/18.

C.E. Australian Corps.

No. 2
TUNNELLING COY.
No.....

APPENDIX **A14**
Part. 1.

Suggested Organisation Corps Lines.

<u>Baisieux.- Ancre.</u>	Major Mulligan 2nd Aust. Tunnlg. Compnay.	2nd Aust. Tunnlg Co. 53 Lab. Group less 168 Company.
<u>Franvillers.</u>	Capt. Horne. 4th. Pioneers.	4th Pioneers (3 Cos) ½ 53 Labor Group less 44th Company.
<u>LaHoussoye.</u>	Major Riddell. 12th Field Co.	12th Field Company. ½ 53 Labor Group 177 Labor Coy.
<u>Querrieu.</u>	Lt. Col. Hearne.	47th Labor Group. less 107 & 177 Lab. Coys.

Signed. E.J.H.Nicholson. Lt Col.
C.R.E. Corps Troops.

12/4/18.

COPY.

Major Mulligan.
O.C. 2nd Australian Tunnelling Coy.

The Army defences in Corps Area have been taken over by Corps under
under C.E. ~~XXXXXXXXXX~~. 1st Aust Corps-- The C.R.E C.T. will
supervise the work.

The lines are known as	
BAIZEUX-- ANCRE	Major Mulligan.
FRANVILLERS.	O.C. 4th Pioneers.
LAHOUSOYE.	O.C. 12th Field Coy.
QUERRIEU.	Lt. Col. Hearne.

The Baizeux--Ancre line will be in your charge. In addition to
your own parties you will be given the whole of the 53 Labour Group ~~ka~~
less one Company. This gives 4 companies and a total of 1,350 men.
O.C. Labour Group . Lt Col. FAWCUS -- H.Q. and camp. PETITCAMON.
Please send requests to the O.C. direct with copies to G.R.E. C.T.
as to times and places men are to assemble for work.
Stores to be drawn from QUERRIEU dump.
Further lines will be laid out tomorrow 13th.

Signed. E.J. Nicholson. Lt.COL.
C.R.E. C.T.

12/4/18.

WAR DIARY.
APRIL 1918.

No. 2
 AUSTRALIAN
 TUNNELLING COY.
 No.....
 Date.....

APPENDIX A (11)

Part. 2.

C.R.E. Corps Troops.
Australian Corps.

C.R.E. WORKS INSTRUCTIONS.

C.R.E instructions From NOS 1 to 10 are cancelled, and the under-mentioned substituted for your information and necessary action:-

- 11. Requirements of R.E. material for Companies working under C.R.E.C.T. will be sent to C.E. (R.E. Stores Officer).
- 12. Daily works report will be sent into C.R.E. C.T. by D.R.L.S. daily. These reports (on accompanying forms) will show work of previous day and distribution of labour for day.
- 13. Defence Plans are to be sent in on Wednesdays and Saturdays by D.R.L.S. TO C.R.E. C.T. These are to on 1/10,000 scale. If plan to this scale is not available then on 1/20,000. These plans will be returned to Unit by C.R.E. C.T. in time for next dispatch date.
- 14. A location list of Companies administered by C.R.E.C.T. companies working under C.R.E.C.T. and Corps R.E. DUMPS will be circulated to companies under C.R.E.C.T. Units concerned will inform C.R.E. immediately of any change of location.

(Signed). D.M. MCCLEAN.
Capt. R.E.
Adj. for C.R.E. C.T.

- O.C. 177th. Tunnelling Coy.
- O.C. 180th. do.
- O.C. 2nd AUST. do. 11/4/18.
- O.C. 4th. " Pioneers.
- O.C. 12th Field Coy. A.E.

INSTRUCTIONS RE DEFENCES.

Units to make gaps not more than 100 yards apart in all new wire on their allotted sectors; gaps to be from 9 to 12 feet wide, also to see that the gaps in any existing wire are increased to agree with above order.

All gaps to be made by Notice boards bearing the words G.A.P. in large letters.

All roads to be provided with knife rests where wire crosses them. Knife rests for the purpose should be two in number, of equal length so that the greater part of a road can be closed but still leaving a track for infantry.

Instructions regarding numbering of strong points will be forwarded when received.

(Signed). D.M. MCCLEAN. Capt. R.E. Adj.
for C.R.E. Aust. Corps Troops.

11/4/18.

Distribution.
to same Units as above.

X Exhaust

WAR DIARY.
APRIL, 1918.

AUSTRALIAN
TUNNELLING COY.
COPY.

APPENDIX

APPENDIX V
S E C R E T.

A.15.

C.E. Australian Corps.

15th April 1918.

59

O.C. 2nd Australian Tunnelling Company.

1. Instructions have been received that the Australian Corps is to take over control of the demolitions of the ten bridges (10) which have been prepared for demolition in AMIENS.
2. The 2nd Australian Tunnelling Company is detailed to be responsible for the actual demolition of these bridges. The orders for the demolition of these bridges will be issued by, or come through, Australian Corps. You will be good enough to detail a party consisting of not less than two Officers and 50 other ranks for the purpose of carrying out (a) the guarding, and (b) the demolition of the bridges on the attached plan.
3. Please submit a set of written orders which you propose should be issued to the Officers and N.C.Os of this party governing the destruction of the bridges in question.
4. Every effort must be made to provide dugout accommodation for the demolition parties. This accommodation should at least be splinter proof and should if possible, be proof against any shell at to 6" H.E.
If conditions permit, it is desirable that the explosion should be controlled from the splinter proof or dugout provided.
5. Each demolition party must be in possession of water and rations for at least 2 days. In addition to this, every officer and sapper must have rifle and 100 rounds of ammunition.
6. Please furnish me with a nominal roll of Officers, N.C.Os and Sappers who you detail to each of these bridges, shewing to which bridge each party is detailed.

④ Signed). C.H. FOOTT.
Brigadier-General.
Chief Engineer. Australian Corps.

Copy to:
"G" Australian Corps.

X Extract

APRIL, 1918.

APPENDIX, A. No. (XVI.).

DEMOLITIONS.
DEMOLITION INSTRUCTIONS. No. 1.

1. The 2nd Australian Tunnelling Coy will be responsible for the guard- and demolitions of the bridges in the Australian Corps Area detailed in the attached tables. The following tables are attached:-
- | | | |
|--|--------------|---|
| | No. 1 Group. | |
| | 2 | " |
| | 3 | " |
| | 4 | " |
2. No. 1 Group. officer in charge Capt. L de J. Grut.
2 " do. Lt. E. M. TOOTH.
3 " do. Capt. A. F. Cohen.
4 " do. Capt. G. L. Smith.
3. In the case of No. 4 Group these instructions are to be regarded as warning only. The officer in charge ~~is~~ will take no action beyond reconnoitring the bridges detailed in his group.
4. RESPONSIBILITY FOR ORDERS FOR DEMOLITION - The group tables show in each case the responsibility for orders for demolition. Orders for actual demolition will be given by the Division. In the case of No. 3 Group orders for demolition will be issued by or through the Australian Corps.
5. Each Group Commander will receive definite instructions re the arrangement arrived at with Divisions for the definite order to blow. In the event of the enemy appearing at close quarters before the order for demolition are received the officer, N.C.O. or sapper in charge will destroy the bridge at his own discretion.
6. ALLOTMENT OF SAPPERS :-
The allotment of sappers to each bridge is shown in the attached tables. In each case 1 sapper of a Party, preferably an N.C.O. must be placed in charge. Additional sappers over and above the allotment shown on the attached tables will be detailed to each group for the tunnelling of abutments and the building of shelters.
6. ABUTMENTS - One abutment of each bridge will be mined.
7. SHELTERS - 2 shelters, each to hold 2 men, will be built near every bridge site.
8. ARMS - Every officer and O.R. will carry a rifle and at least 100 rounds of ammunition.
9. RATIONS - Each demolition party will have rations and water for 3 days
10. INFORMATION - No information is to be given to any but duly authorised persons. The ~~xxxx~~ Field Engineer for demolitions for the Australian Corps is Captain Burnell, M.C., A.E. and every facility will be given him to keep in touch with the work and general arrangements.
11. REPORTS - In every case of actual demolition a report will be forwarded to H.Qrs as to the result of such demolition.

Major. O.C.

2nd Australian Tunnelling Coy.

16/4/18.

X Exhaid

DEMOLITION INSTRUCTIONS NO d,

2nd AUSTRALIAN TUNNELLING COY.

Serial No.	Location	River	Description	Allotment of Sappers	Responsability for Demolition Orders,
No. 2					
GROUP No; 1,					
1.	0.5c 4.7.	Corbie, Somme	Steel girder bridge across lock,	4	A Div.
2.	0.5c 3.5	" "	Steel girder bridge 50' span,	4	"
3.	0.5c 2.9	" "	Brick arch bfridge 20' span.	4	"
XXV67.	0.5c 5.5	" "	Doubling existing bridges,	4	B
68.	0.5c 5.8	" "	" " "	4	"
18.	I.33d 8.7.	La Neuville Ancre	3 girders 21'6" span.	4	"
19.	I.34a 6.0	" "	" " "	4	"
38.	I.33d 0.0.	" "	R.S.Js 14' span.	4	"
56.	I.28 c,	" "	3 Small timber bridges	2	"
6.	0.1c 1.4.	Daours Somme	Steel girder bridge 22' span	4	"
7.	N.6 d 8.5.	" "	72' span steel trusses.	4	"
20.	N.6 c 5.2z	" "	Small foot bridge over mill stream	4	"
69.	0.1 c 2.5.	" "	60' mark II,	4	"
70.	N 6 d 8.4z	" "	90' Hopkins.	4	"
79.	N 6 d 8.9.	" "	" " "	4	"
4.	0 11 a 0.8.	Fouilloy	Masonry bridge 12' span.	4	"
5.	0 4 d 6.4.	" "	" " "	4	"
----- GROUP. No, 2. -----					
17.	I 23 b 3.6	BONNAY, Ancre.	2 small masonry arches	4	B Div.
37.	I 23 b 6.5	" "	Reinforced concrete bridge,	4	"
53.	I 18 c.	" "	5 small timber bridges.	2	"
54.	I 23 c.	" "	4 small timber bridges.	2	A Divm.
15.	J 4 a 6.1.	RIBEMONT Ancre.	Steel girder 18' span.	4	B Div.
34.	J 4 a 3.4.	" "	Brick arch bridge 8' span.	4	"
35.	J 3 c 9.8.	" "	Brick arch bridge 20' span.	4	"
16.	J 7 b 2.7.	HEILLY	Masonry arch 8' span.	4	"
36.	J 7 b 1.9.	" "	8' span.	4	"
51.	J 2 c 3.7.	" "	2 small trestle bridges.	2	"
52.	J 7 cent,	" "	2 small timber bridges.	2	"
55.	I 29 a.	" "	small timber and pontoon bridges	2	A "
32.	D 29 d 50.06	BUIRE	6 I. Beams 9" x 4" span.	4	B "
33.	J 5 b 6.8.	" "	Masonry arch bridge, 15" ring 15' span.	4	"

APPENDIX A XVII

Serial No.	Location.	River.	No. 3 GROUP.	Description.	Allotment of Sappers.	Responsability for Demol Orders
80.	Bvde de Beauville (AMIENS)	Somme.		7 Girders 80' span.	4	Aus Corps.
81.	" Canal North of "	"		80, Brick arch 30' span.	4	"
82.	Bvde Baraban (AMIENS)	Somme.		3 girders, Jack arches 40' span.	4	"
83.	Rue Saint Leu.	"		5 girders, 30' span.	4	"
84.	Rue du Jardin des Plantes.	"		30' span.	4	"
85.	Rue du Chateau Milan.	"		2 Lattice girders 80' span.	4	"
86.	Pont Saint Michal.	Canal.		Brick arch 30' span.	4	"
87.	Pont d' Amont.	"		3 Masonry arches, 30' span overall.	4	"
88.R	Rue des Majoté.	"		4 girders, 30' span.	4	"
89.	Quai St Maurice.	"		Lock.	4	"

No. 4 GROUP.

8.	N 15 c 9.3.	La Motte	Somme.	Bridge over masonry spillway	4	
9.	N 15 c 6.4.	"	"	Light reinforced concrete 150' long.	4	
60.	N 14 d 1.3.	"	"	84' Inglis bridge.	4	
11.	M 16 d 7.6.	Camon.	"	57' span steel ytrusses.	4	
13.	M 15 b 2.3.	"	"	Continuous girder bridge.	4	
14.	M 15 b 3.1.	"	"	Small girder bridge.	4	
73.	M 16 d 7.5.	"	"	57' steel girder bridge.	4	
12.	M 22 b 6.1.	Longueau.	"	19' span girder bridge.	4	
72.	M 22 b 6.2.	"	"	19' span.	4	
74.	M 22 c 4.5.	"	NOYE	60' A.	4	
57.	N 17 c 8.4.	Blangy.	Somme.	Pontoon Bridge.	4	
		Tronville.	"			
71.	N 15.	"	"	2/16' Mark II & 2/21'6" Mark II	4	
58.	N 16 c 7.3.	"	"	Pontoon Bridge.	4	
59.	N 15 c 8.4.	"	"	Trestle bridge across lock.	4	

WAR DIARY.

APRIL, 1918.

APPENDIX NO. A (XVIII).

DEMOLITIONS.

2nd Australian Tunnelling Coy.

LOCATION OF OFFICERS.

No. 1 GROUP:-

Capt. L.de J Grut.	2nd. Aust. Tunnlg Co. H.Q.
	3 Lombard Street. Querrieu.
Lieut. D.C. McKenzie.	La Neuville. ---I 34 a 6.0.
" F.H. Hooper.	Daours. ---N 6 c 9.4.

No. 2 GROUP.

Lieut. E.M. Tooth.	2nd Aust. Tunnlg Co. H.Q.
Lieut. N.J.P. Broome.	HEILLY. ---J 7 D 2.7. (10th Fld Coy.)
" K.B. Lewis.	RIBEMONT. ---J 4 a 6.1. -
	(10th Fld Coy. Advanced Billets)

No. 3 GROUP.

Capt. A.F. Cohen.	AMIENS. --- In house near brige over
	Somme, Bvde du Jardin des Plantes, near
	Citadel- Guard on bridge will direct.
Lieut. LL. Wrathall.	do. do.
Lieut. H.V. Pethebridge.	do. do.

No. 4 GROUP.

Capt. G.L. Smith.	2nd Aust. Tunnelling Co. H.Q.
Lieut. A.W. Johnson.	Near Railway station La Motte Brebiere
	N 14 c 9.2.

Major. O.G.

2nd Australian Tunnelling Coy.

18/4/18.

No. of Message.....

Words.....	Received.	Sent, or sent out.	Office Stamp.
t s. d.	From.....	At.....m.	NDL 510
	By.....	To.....	

Charges to Collect

Service Instructions

Handed in at AUO Office.....m. Received 959h m.

TO 2 Aus Tunneling Coy

* Sender's Number.	Day of Month.	In reply to Number.	AAA
<u>4115</u>	<u>22</u>		<u>AAA</u>
<u>Under</u>	<u>4th</u>	<u>Army</u>	<u>Orders</u>
<u>a</u>	<u>Section</u>	<u>179th</u>	<u>Tun</u>
<u>Coy</u>	<u>RE</u>	<u>now</u>	<u>with</u>
<u>2nd</u>	<u>Aus</u>	<u>Tun</u>	<u>Coy</u>
<u>total</u>	<u>4</u>	<u>officers</u>	<u>17 OR</u>
<u>will</u>	<u>move</u>	<u>by lorry</u>	<u>from</u>
<u>QUERRIEU</u>	<u>SIBIVILLE</u>	<u>on Apr 20</u>	<u>and Embas</u>
<u>at</u>	<u>QUERRIEU</u>	<u>at</u>	<u>8 am</u>
<u>aaa</u>	<u>Debar</u>	<u>at</u>	<u>SIBIVILLE</u>
<u>where</u>	<u>billets</u>	<u>will be had</u>	
<u>from</u>	<u>Camp</u>	<u>warden</u>	<u>and Unit</u>
<u>comes</u>	<u>under</u>	<u>10th</u>	<u>Corps</u>
<u>Officer</u>	<u>will</u>	<u>report</u>	<u>to</u>
<u>CE</u>	<u>10th</u>	<u>Corps</u>	<u>at</u>
<u>CLOQUE</u>	<u>aaa</u>	<u>Rations</u>	<u>for 2nd</u>
<u>to</u>	<u>be</u>	<u>carried</u>	<u>aaa</u>
<u>2nd</u>	<u>Aus</u>	<u>Tun Coy</u>	<u>repto</u>
<u>and</u>	<u>3rd</u>	<u>Aus</u>	<u>5th</u>
<u>FROM</u>	<u>2nd</u>	<u>Aus</u>	<u>5th</u>

PLACE & TIME Aust Corps

* This line should be erased if not required.
 (3966) Wt. W528/M1970. 100,000 Pads. 5/17. H. W. & V., Ltd. (E. 1213.)

Prefix.....Code.....Words.....

Received: Sent, or sent out. Office Stamp.

From..... At.....m.

By..... To.....

Charges to Collect

Service Instructions

Handed in at AUO Office.....m. Received 1251h m.

TO 2 Aust Tunnel Coy

* Sender's Number.	Day of Month.	In reply to Number.	AAA
<u>9834</u>	<u>22</u>		<u>AAA</u>
<u>"A"</u>	<u>Section</u>	<u>179</u>	<u>Tunnel</u>
<u>Coy</u>	<u>will</u>	<u>be</u>	<u>prepared</u>
<u>to</u>	<u>move</u>	<u>by</u>	<u>lorry</u>
<u>from</u>	<u>QUERRIEU</u>	<u>at</u>	<u>7</u>
<u>lorry</u>	<u>23rd</u>	<u>inst</u>	<u>on</u>
<u>transfer</u>	<u>to</u>	<u>3rd</u>	<u>Army</u>
<u>aaa</u>	<u>Acknowledge</u>		

FROM Aust Corps

PLACE & TIME

* This line should be erased if not required.
 (19629) Wt. W528/M1970. 300,000 Pads. 4/17. M.C. & Co., Ltd. (E1213.)



APPENDIX

cap 64

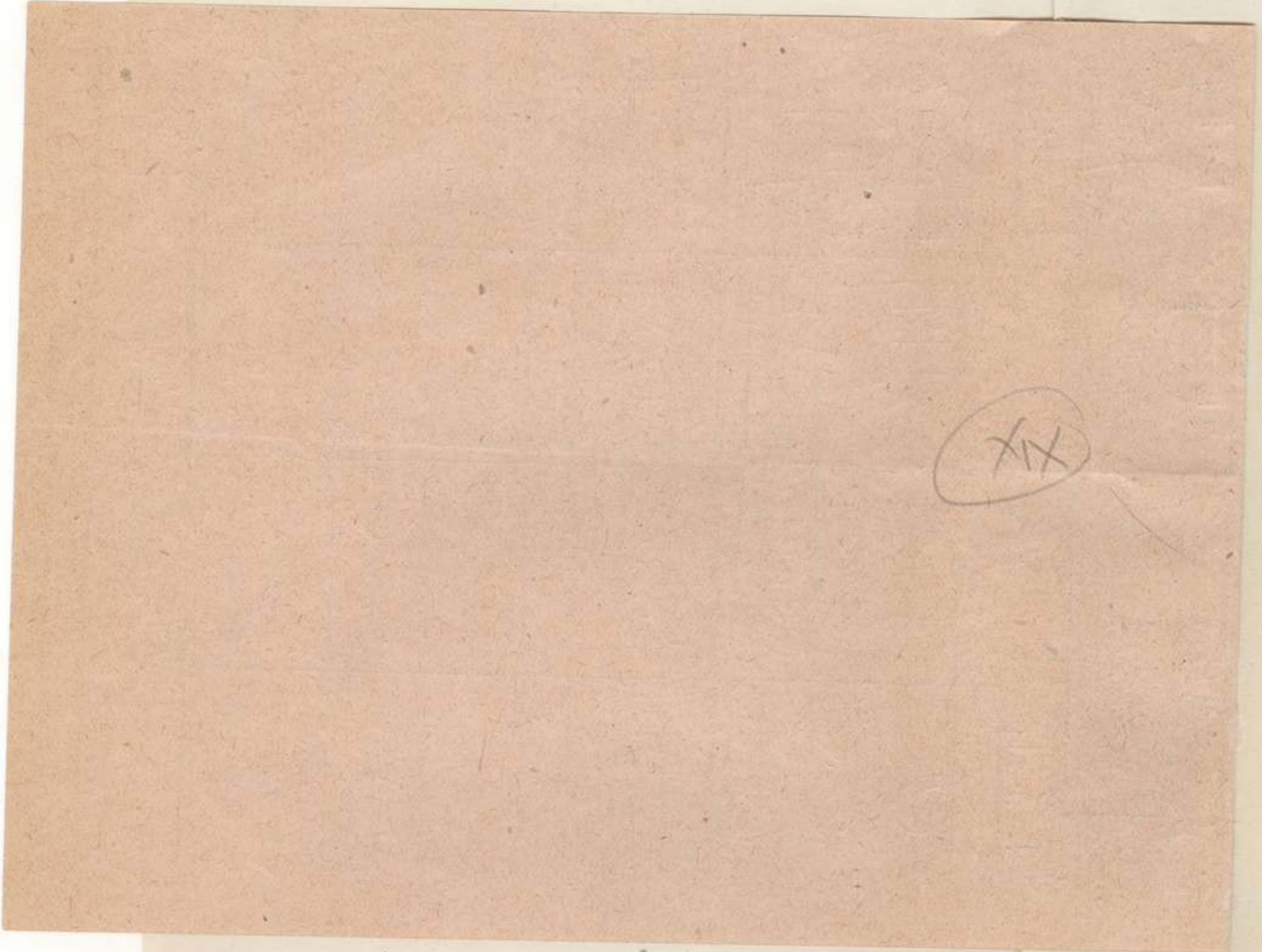
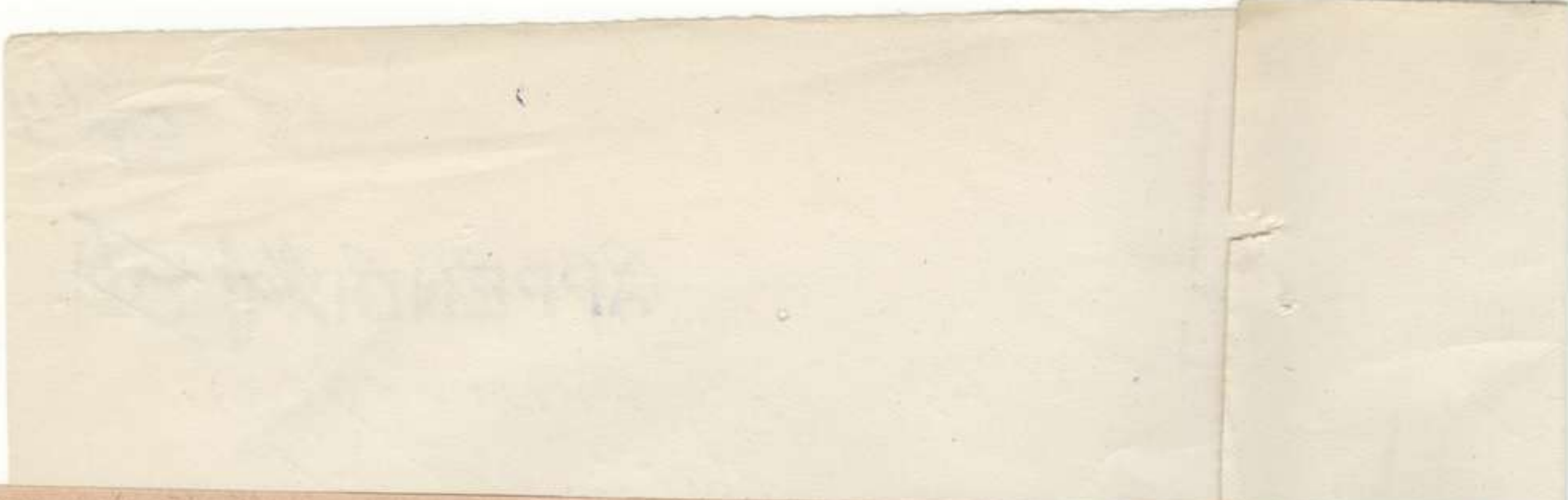

XIX

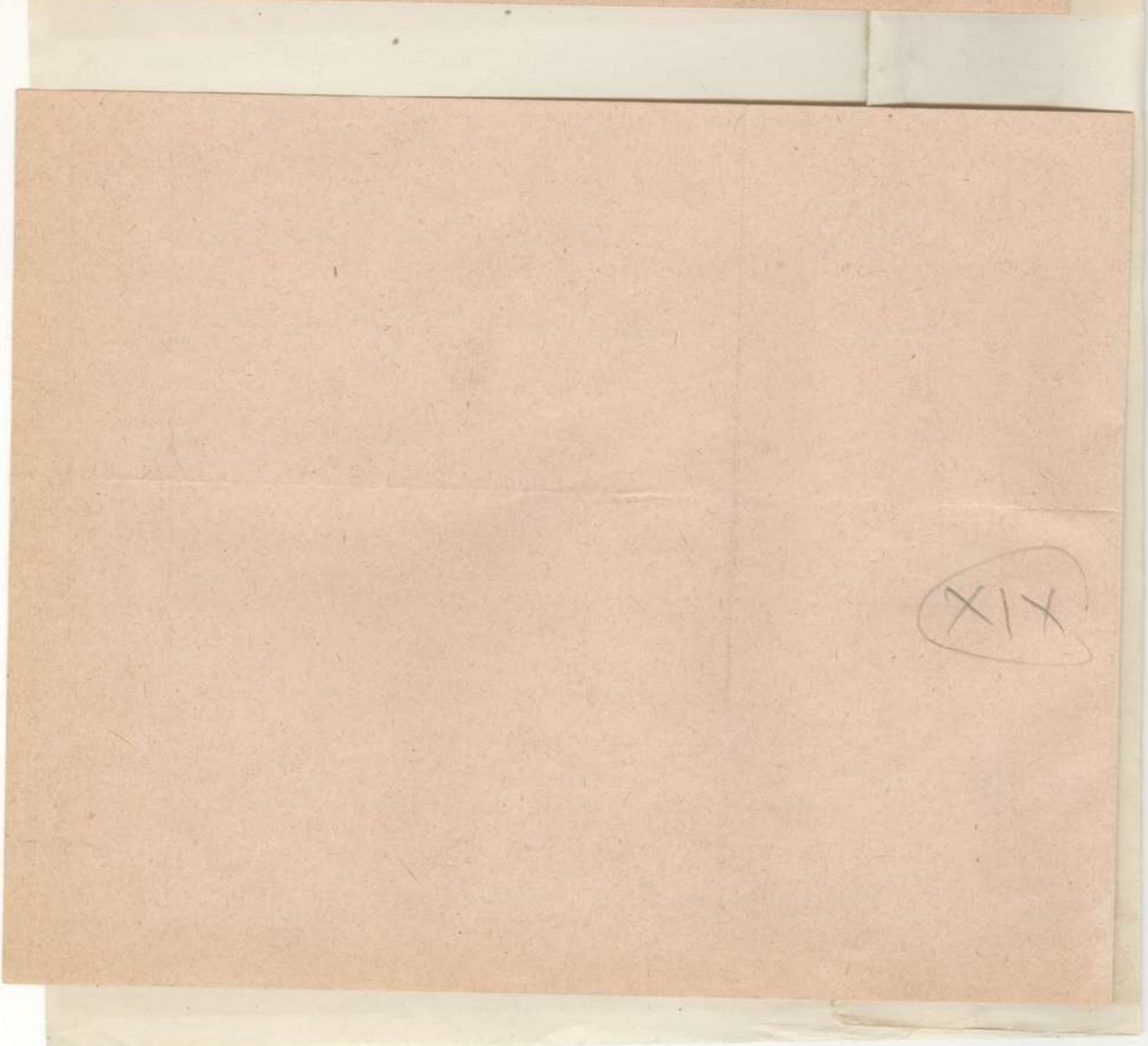

XIX

COPIES OF LETTERS AND TELEGRAMS.
ATTACHED UNITS. ETC.,

To. 2nd Australian Tunnelling Coy.

SENDERS No. G 418.

Under 4th Army Orders a section of the 179th Tunnelling Coy. R.E. now with 2nd Aust. Tunlg Coy total 4 officers, 47 O.R. will move by lorry from QUERRIEU to SIBIVILLE on April 23rd and Embus at QUERRIEU at 8 a.m. aaa Debus at SIBIVILLE where billets will be had from Camp Warden and Unit comes under 10th Corps aaa Officer will report to C.E. 10th Corps at HAUTECLOQUE aaa Rations for 24th to be carried aaa addsd 2nd Aust. Tun. Coy. Reptd C.E. Aust. Corps. and 3 Aust. Div.

22/4/18.

From Aust Corps.

2nd Aust. Tunnl Coy.

Senders No. G 834.

"A" section 179 Tunnelling Coy will be prepared to move by lorry from QUERRIEU at 7 a.m. 23rd inst on transfer to 3rd Army aaa Acknowledge.

22/4/18.

from Aust Corps.

To 2nd Australian Tunnelling Coy.
QUERRIEU.

1 Officer and two N.C.OS of U.S. Engineers will report to you on 28th aaa 2 Coys U.S.E. will arrive at FRANVILLERS on night of 29th. Addsd 2nd Aust. Tun Coy. and 180 Tun Coy. reptd 6th Regt U.S.E.

From C.E. Aust Corps.

22/4/18.

Copy of telegram and reply.

To. 2nd Australian Tunnelling Coy.

Wire G.S. wagon transport required.

29/4/18.

from C.E. Aust. Corps.

To. C.E. Aust. Corps.

4 more G.S. Waggon required - 4 Horse teams.

29/4/18.

from 2nd Aust. Tunng Coy.

S.W. No

C.R.E. Australian Corps Troops No. 7

AUSTRALIAN
TUNNELLING COY.
O.C. 2nd Australian Tunnelling
Company A.E.
Date.....

C. R. E.,
CORPS TROOPS.
No. *21/*
Date.....

QUERRIEU.

Commencing to-morrow the following
are available for Defence Works under your
orders :-

53rd Labour Group at H.20.b.3.3.
5 Companies less 44th Labour Company.

W.H. Chan

Captain, R.E.,
Adjutant
for C.R.E. Aust Corps Troops.

12/4/18.

56/4



WAR DIARY.

No. 2
AUSTRALIAN
TUNNELLING COY.

COPIES OF LETTERS AND TELEGRAMS -

WORK ON DEFENCE LINE.

Date.....

67

APRIL 1918.

APPENDIX A. 20.

To. O.C.
Sections.

The men now working on BAIZIEUX- RIBEMONT will be transferred to La Neuville - Bonnay Line tomorrow 13th inst. One shift only will be worked. No. 2 Section with 179 Tunnelling Coy detachment will move off by lorry at 8 a.m. Nos 1 and 3 Sections will march off at 9 a.m. and be picked up by lorries on the road, if the lorries have not returned to H. Qrs by that hour. The same order will be observed on returning to H. Qrs. Each man to carry a pick and shovel.

All officers to be on parade tomorrow. On subsequent days 50% only need be present.

(Signed). G.I. ADCOCK. Capt. Assist to O.C.
2nd Australian Tunnelling Coy.

12/4/18.

To. O.C.
2nd Australian Tunnelling Coy.

Commencing to-morrow the following are available for Defence Works under your orders. :-

53rd Labour Group at H 20. b 3.3.
5 Companies less 44th Labour Company.

(Signed). W.N. MCLEAN.
Captain. R.E.
for C.R.E. Aust. Corps Troops.

12/4/18.

To O.C.
2nd Australian Tunnelling Coy.

WAR DIARY No. 2

AUSTRALIAN
TUNNELLING COY.

APRIL 1918.

APPENDIX A No. (7) 1
PART. A. 21

COPIES No. OF GROUP OFFICERS REPORTS.

Date

NH

TO. O.C. 2nd A.T. COY.

16. 4. 18.

Report on Bridges at DAOURS.

- No. 1. 8 Charges (Guncotton) (light. At present there are 8 independant firing points. Will remedy on receipt of instantaneous fuse. Fuse only.
- No. 2. 178 R.E. state 2 50lbs charges Ammonal and 2 15 lb charges Guncotton. Fuse only.
- No. 3. 2 Guncotton charges in centre of girders - Waiting for fuse, at present there is electric system only.
- No. 4. 2 Guncotton charges in centre of girders - Electric and fuse.
- Nos. 5, 6, 7, & 8. Charges removed on the 14/4/18.
- No. 9. 2 Guncotton charges (light) in centre of girders. Fuse only.

Note. In 3 cases out of 4 the fuse joints removed from 5, 6, 7, & 8. Bridges on being tested were found to be faulty. In view of the above we think it would be advisable that all existing fuse systems be done over again.

Abutments.

The work has not been started on any of these, we have only sufficient men to act as sentries at present. We shall require at least 8 extra men when this work starts.

(Signed). E. M. TOOTH. Lieut.
No. 1 Section. 2nd A.T. COY.

No. 10 and 11 (New Bridges) are not yet charged awaiting arrival of Material.

O.C.
2nd Aust. Tun. Coy.

The Hopkins Bridge M 1 is now complete and ready for Mining.
Map Location of bridge (Sheet 62d S.W. N 6 d 8.5.

(Signed). A. Anderton.
Capt. R.E.

16/4/18.

O.C. 574 (Cornwall) A.T. Coy. R.E.

X Exhaust

18/4/18.

Officer in Charge. Lieut. D.C.MCKENZIE. I 34 a 6,0,

No,	Location.	Description of charges.	Material Required.	Blown on Authority.
1.	0 5 c 4.7.	Corbie. Fuse and electric firing.	No abutment.	
1a.)	"	" Small foot bridge.	Charge possible.	
2.	0 5 c 3.3.	" Fuse and electric firing.	300 lbs H.E. 60 yards electric leads, mining sets. Sand bags.	
3.	0 5 c 2.0.	" Fuse and electric firing.	- do,-	
4.	0 11 a 0.8.	Fouilloy. Not charged.		
5.	0 4 d 6.4.	" Fuse and electric firing.	No abutment.	
67.)	Not in position yet. Doubling existing bridges.			
68.)				
18.	I 33 d 8.7.	La Neuville. Fuse and electric firing.	300 lbs H.E. 60 yards electric leads, mining sets.	
19.	I 34 a 6.0.	" Fuse only.	No abutment charge.	
X.	I 33 c 6.2.	" "		
Y.	I 28 c & d.	3 small timber bridges all charged.	300 lbs H.E. electric leads.	

Officer in charge. Lieut F&H.HOOPER. DAOURS. N 6 c 8.4.

6.	0 1 c 1.5.	Daours. Electric and fuse.	300 lbs H.E. electric fuse leads 50 yards, Mining sets.
	"	" Doubling existing bridges.	100 lbs gun cotton. Primers. Commercial detonators. Fuse.
7.	N 6 d 8.5.	Daours. Electric and fuse.	300 lbs H.E. electric leads, Mining sets.
	"	" Doubling existing bridges.	60 lbs guncotton Primers, Electric and Commercial detonators.
20.	N 6 c 5.2.	" Fuse.	
79.	N 6 d 8.0.	" Fuse.	100 lbs for abutment electric leads
	N 6 c 8.4.	" Fuse.	ditto.

(Signed) L de J GRUT. Capt,
No. 1 Section,
2nd Australian Tunnelling Coy

X
 Appendix
 APPENDIX A.21

War Diary.

APPENDIX A (X11)
April 1918. A.22.

COPY.

C.E. Australian Corps.

70

28th. April 1918.

2nd Aust. Div.
3rd. Aust. Div.
4th. Aust. Div.
5th. Aust. Div.



Please let me have as soon as possible your proposals for dugouts for :

- (a) Brigade Headquarters.
- (b) Battalion Headquarters.
- (c) Command posts.
- (d) M.G. Dugouts. (In forward zone only).
- (e) R..A.PS. and A.D.S.

In the selection of sites for (a) (b) (c) and (e) consideration must be given to requirements in -

- (a) The present Divisional Zone.
- (b) The Zones in rear thereof, up to the line of the Sallue inclusive.

In order to expedite matters, you may send in your proposals in parts, if you are not able to submit the whole programme at once.

(Signed) C.H.FOOTT.
Brigadier-General.
Chief Engineer Australian Corps.

Copy to :
G.O.C.R.A.
C.R.E. C.T.
172 Tunnelling Co.
180 do.
182 do.
254 do.
256 do.
2nd AUSTRALIAN TUNNELLING COY.
"G" Aust. Corp s.

A. 73.
71

No. 2
AUSTRALIAN
TUNNELLING COY.
C.E.
Date

COPY.

G.
Australian Corps.

26th April, 1918.

Reference this office G 173/470 of 20th inst.

1. Construction of dug-outs Nos 6 and 7 (at C 15 a 05.70. and C 2 d 9.1.) will be held up temporarily owing to the construction of the new line of posts through C 15, - C10. - C 4, probably necessitating more urgent work on that line.

2. The locations of positions of dug-outs 11 to 14 inclusive has been slightly altered and should now read as follows:-

- 11. I 10. d 4.5.
- 12. I 16. a 8.7.
- 13. I 12. a 2.0.
- 14. I 5 c 7.5.

An officer of the 2nd Australian Tunnelling Coy. detailed by O.C. 2nd Australian Tunnelling Coy. (as well as Lieut HEALEY) has been shewn the new positions and requirements on the ground.

3. Positions for additional M.G. dug-outs have been selected at locations as under :-

- 15. I 15 d 8.5; (already shewn to officer 2nd A.T.C on ~~the~~ ground.
- 16. I 21 b 05.90 " " " "
- 17. I 28 a 2.7. " " " "
- 18. I 6 d 7.8. " " " 180th T.C.
- 19. D 1 b 80.75. " " " "
- 20. U 30 d 1.5. " " " "
- 21. U 29 d 90.75. " " " "

Please issue instructions for these additional dugouts to be put in hand as soon as possible.

(Signed). R.F. CASEY. Major.
for Brigadier-General.
General Staff.
Australian Corps.

---2---

CE Australian Corps.

27th April 1918.

2nd Australian Tunnelling Coy. A.E.

WH-----

Please arrange as far as these instructions concern you.

(Signed). C.D. Sheldon. Capt. R.E.
Staff Officer to Chief Engineer.
Australian Corps.

Copy. to C.R.E. C.T.

for information.

No. 2
 AUSTRALIAN
 TELEGRAPH GOV.
 No.
 Date

APPENDIX *AXY*
 72

b.w.m. "C" Form. *133* Army Form C. 2123.
 (In books of 100.)
 MESSAGES AND SIGNALS. No. of Message.....

Prefix.....	Code.....	Words..... <small>* s. d.</small>	Received. From.....	Sent, or sent out At..... m.	Office Stamp.
Charges to Collect			By.....	To.....	
Service Instructions.			By.....		
Handed in at.....			Office.....	m. Received.....	m.
TO <i>OC 2nd Aust Tunneling Coy</i>					
*Sender's Number. <i>M 171</i>	Day of Month. <i>21</i>	In reply to Number.		AAA	
<i>Arrange for an office to be available tomorrow about 2 pm to accompany an officer of the General Staff and Field Engineer to note site selected for MG dugouts area</i>					
FROM <i>GRE BT</i>					
TIME & PLACE					

*This line should be erased if not required.
 100,000.—John Rissan. Ltd.—8/17.—8141. Forms C2123.



(Handwritten in a circle) X.X

Handwritten: K.W.M

Prefix Code

Charges to Co
Service Inst

Handed i

APPENDIX

Handwritten: 1924
72

Copies of letters and telegrams.
DUGOUT WORK!

To. O.C.
2nd Australian Tunnelling Coy.

Senders No. U 171.

Arrange for an officer to be available tomorrow about 2 p.m. to accompany an officer of the General Staff and Field Engineer to note site selected for M.G. Dugouts aaa.

21/4/18.

from. C.R.E.
Corps Troops.

C.E. Australian Corps.
27thn April 1918.

O.C. 2nd Australian Tunnelling Coy.

You may commence drawing mining ~~xxxx~~ timber from FOULAINVILLE R.E. Dump.

In your orders to the dump please state numbers of pieces required giving lengths.

Lengths in stock.

6' 6"
3' 3"
5' -

(Signed). A.M. GREENLEES. Capt. A.E.
Stores Officer for C.E.
Aust Corps.

SECRET.

Australian Corps.

April 28th. 1918.

2nd Australian Tunnelling Coy.

Arrange to construct the following tunnelled dugouts for the O.Ps of the 5th Field Survey Coy. R.E. at:-

J 30 c 2.2.
J 24 d 3.3.
J 20 a 5.6.

Each dugout to provide accommodation for four men but all details will be given you direct by Captain Chapman R.E. at Headquarters of Observation Group. (No. 15) located at I 14 d 2.3.

Plans of dugouts with map locations to be forwarded to this office.

(Signed). C.D. SHELDON. Capt. R.E.
S.O.R.E. Aust. Corps.

Copy to 5th Field Survey Coy. R.E.

COPIES OF ORDERS R--
SURVEY OF EXISTING DUGOUTS AND CAVES.

C.E. Australian Corps.

29th April. 1918.

2nd Australian Tunnelling Coy.

EXISTING DUGOUTS IN AUST. CORPS AREA.

@@@@@@@@@@@@@@@@

1. O.C's of Tunnelling Coy. will detail Officers to investigate and report on all existing dugouts - caves and tunnels in the Divisional Area for which they are responsible.
2. Reports (complete with plans) to contain details of accommodation - sanitation - lighting - age - locality and head cover etc.
3. Reports to be forwarded as each system is completed and not held up until the whole Divisional Area is surveyed.
4. Details of accommodation in CORBIE - DAOURS and AUBIGNY are particularly required and will be treated as urgent.
5. Negative information for villages is of value.

(Signed). C.D.SHELDON. Capt. R.E.
S.O.R.E. Australian Corps.

Copy to:
"G" (I)

Capt. Phippard.

1. You will investigate the following villages for dugouts, caves and tunnels :- Pont Noyells, Querrieu, ALLONVILLE, Camonnette, St Gratien, Frechencourt, Franvillers, La Houssoye.
2. You will report on each village and give plans with details of accommodation, sanitation, lighting, age, locality and headcover of any dugouts caves or tunnels found.

30/4/18.

(Signed). E.N.MULLIGAN. Major. O.C.
2nd Australian Tunnelling Coy.

Lieut. Tooth.

1. You will investigate the following villages for dugouts, caves and tunnels :- Bonnay, Heilly, Ribemont, Buire.
2. You will report on each village and give plans with details of accommodation, sanitation, lighting, age, locality and headcover of any dugouts, caves or tunnels found.

30/4/18.

(Signed). E.N.MULLIGAN. Major. O.C.
2nd Australian Tunnelling Coy.



MONTHLY REPORT OF MEDICAL OFFICER.

At the commencement of APRIL 1918 the 2nd Australian Tunnelling Coy entered billets at QUERRIEU.

During the month 681 men attended Sick Parade with Influenza septic throats, rheumatism and diarrhea; a number greater than usual due no doubt to the contributed effect of fatigue.

Thirty one were sent back thro' the Field Ambulances, with Hernia, Appendicitis, chronic Rheumatism and broncho-pneumonia.

Ten lost their lives; 6 from shell fire and 4 from gas.

Six gassed men and 5 wounded were evacuated.

Two died in England from natural causes.

A. A. M. G.

Capt. A.A.M.G.

2nd Australian Tunnelling Coy.

1/5/18.

War Diary

April 1918

Appendix A No. (XXVII)

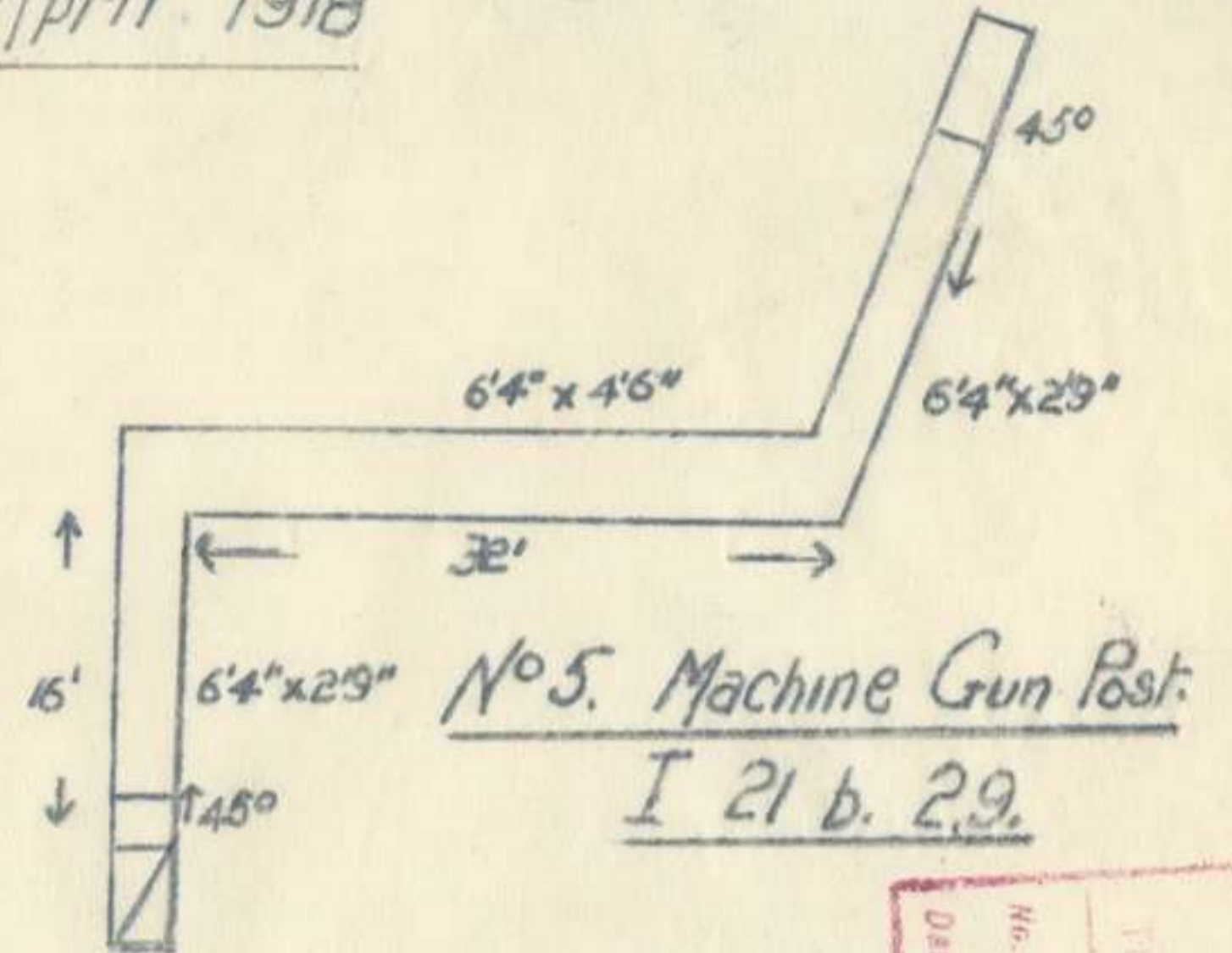
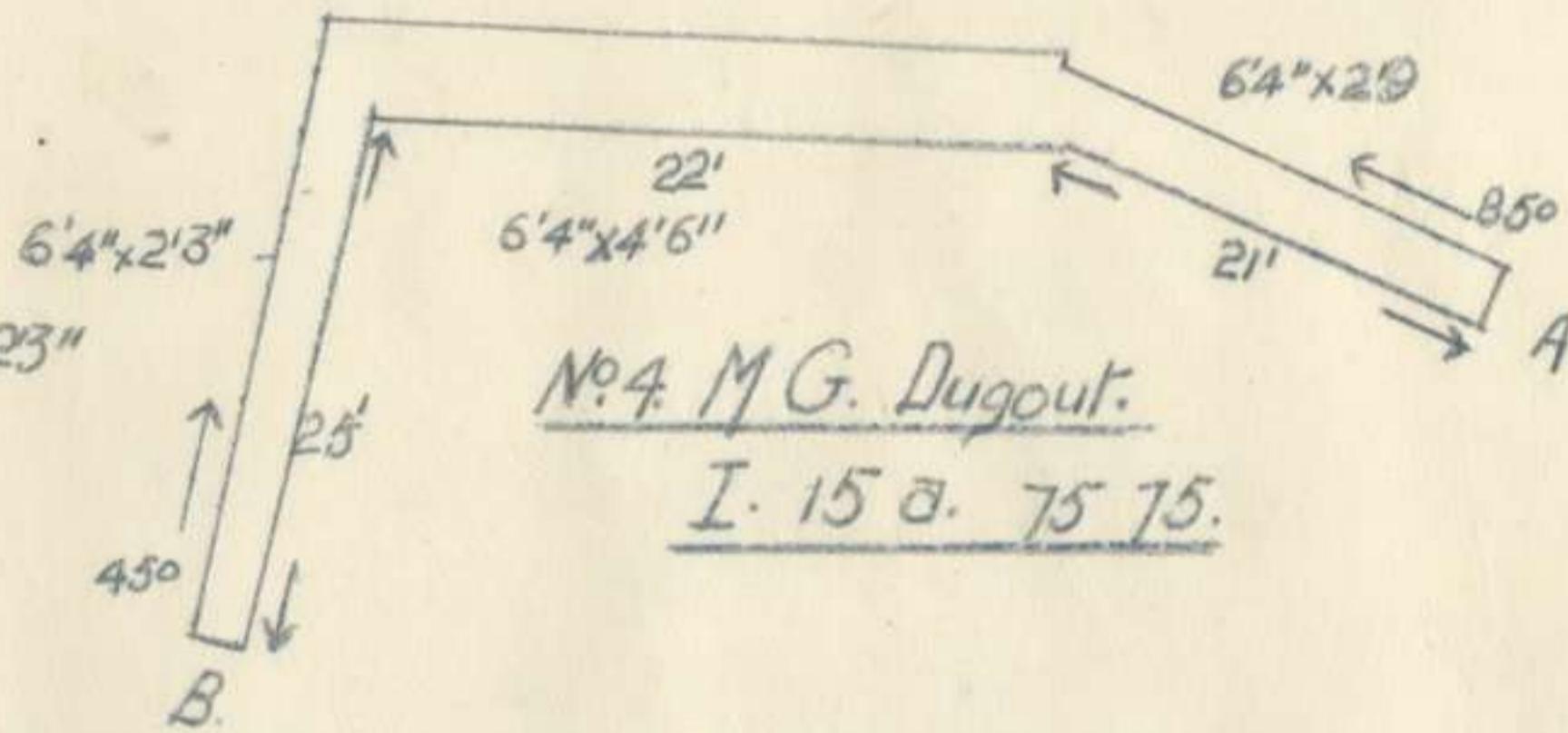
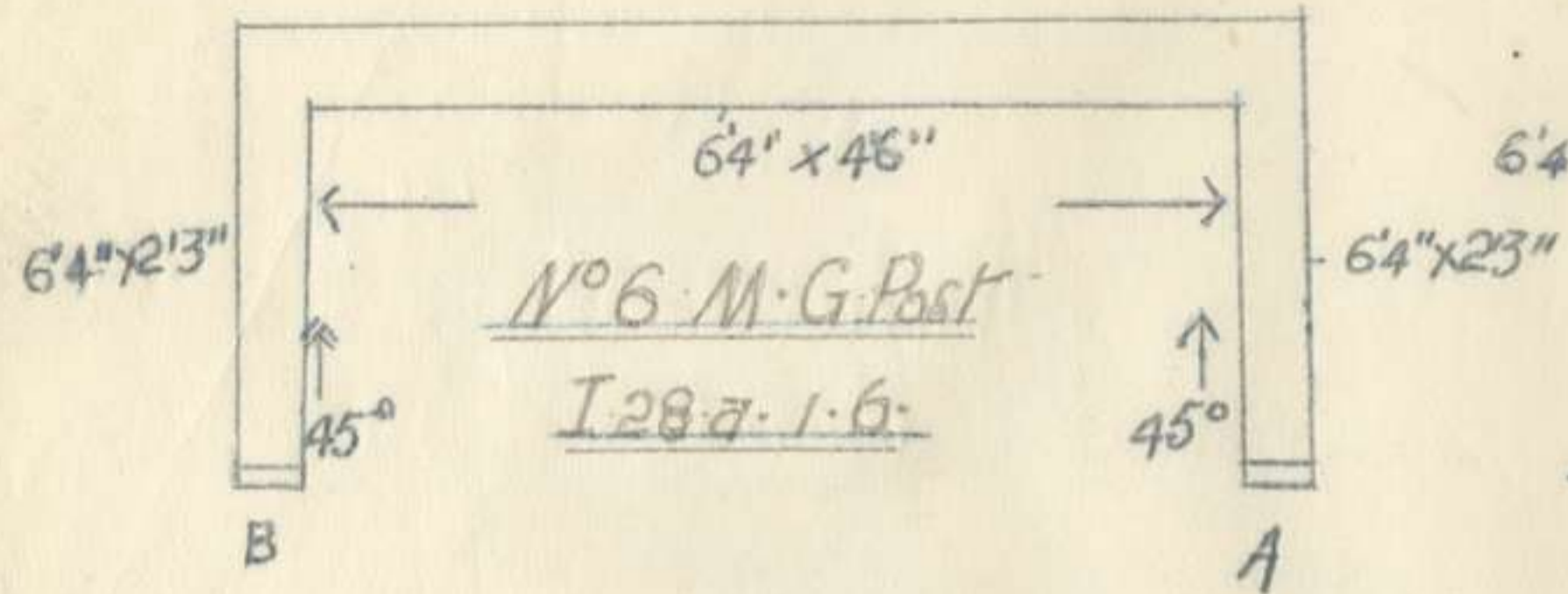

Scale 1 inch = 20 feet.



Keston APPENDIX A No. 1

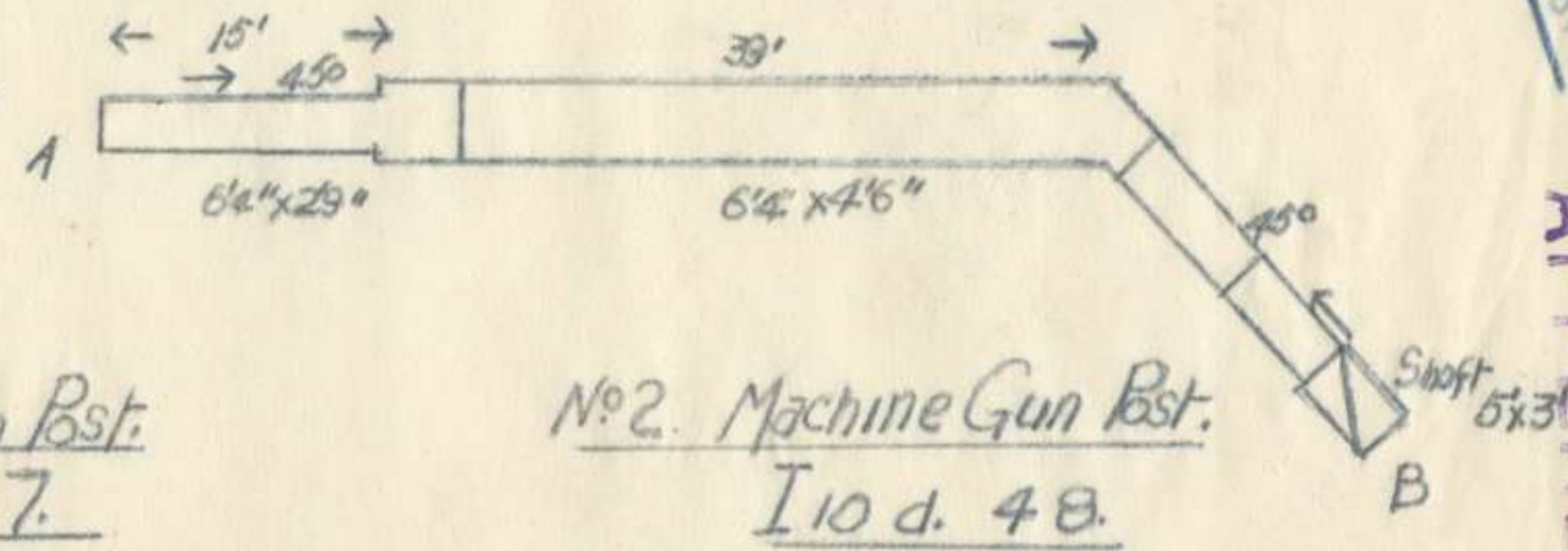
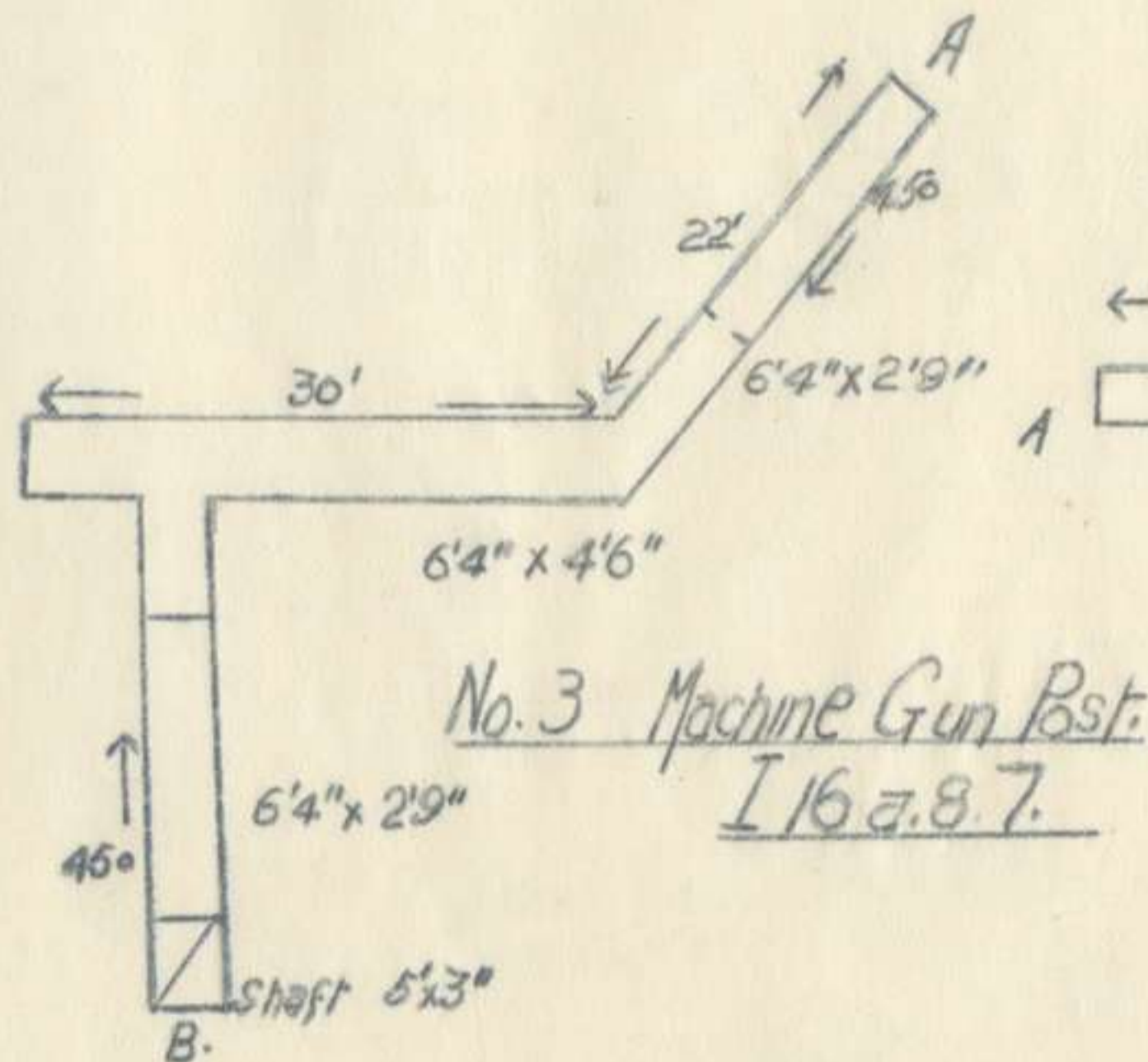
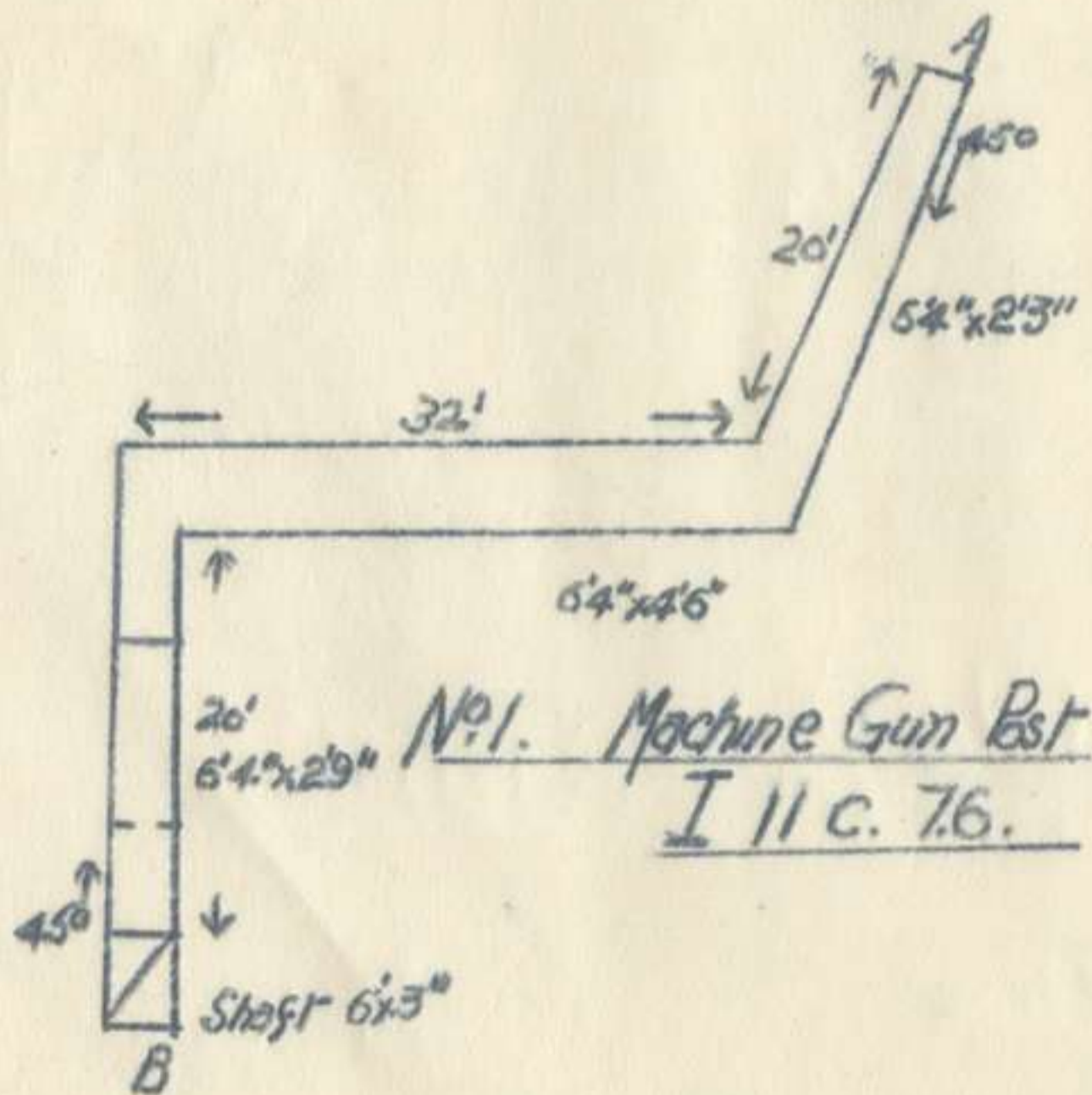

2nd Australian Tunnelling Coy.

No. 2
 AUSTRALIAN
 TUNNELLING COY.
 No. WAR DIARY.
 Date

2nd. Australian Tunnelling Coy.

April 1918.

Observation Posts.

Scale 1 inch = 20 feet.

I 24 d 35.27.

J 20 a. 44.56.

I 30c 1306.

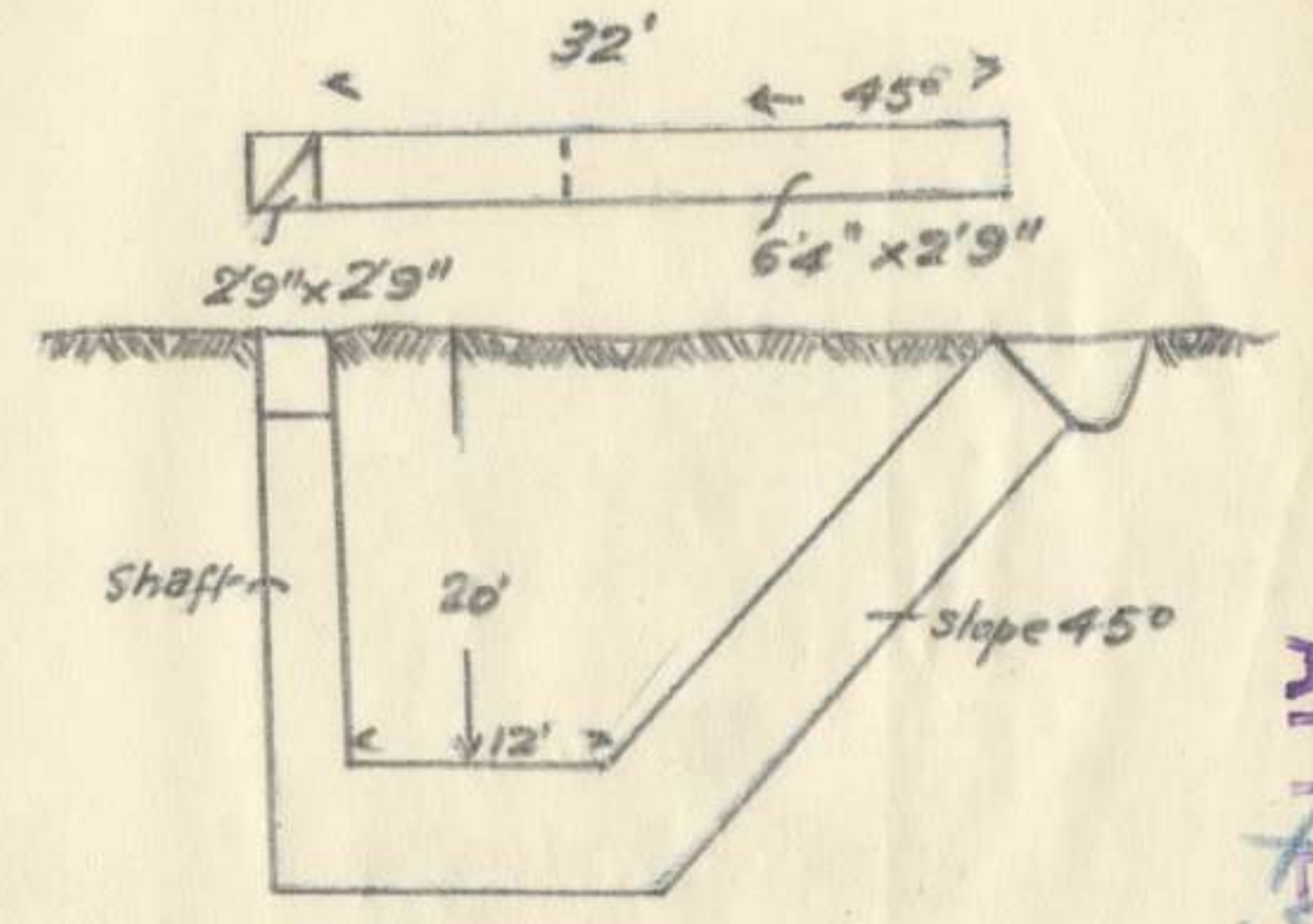
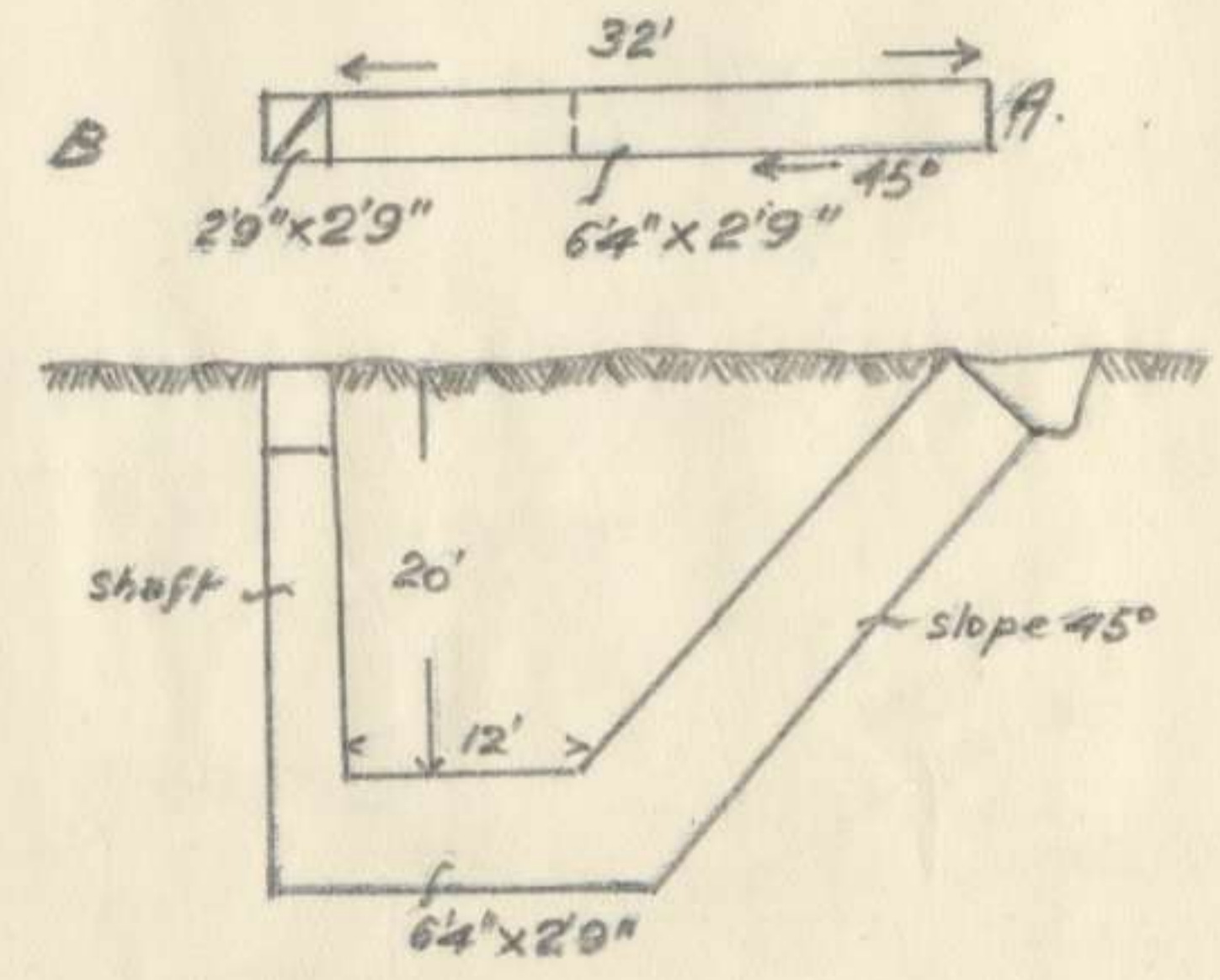
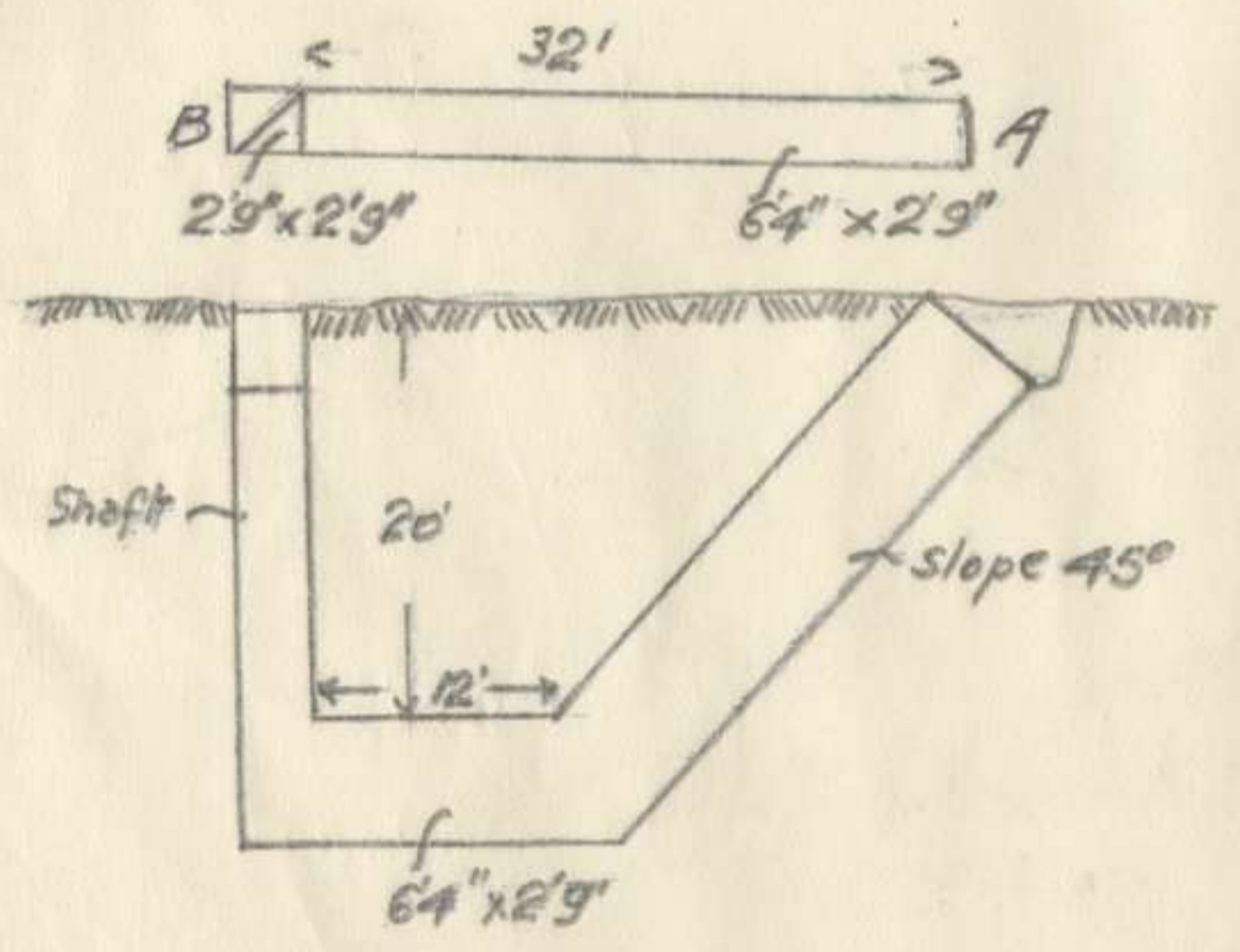

APPENDIX
 A.28.

Description of Models

- N^o 2 Companies No. Deep Dig dug in Coast Sand Dunes
- N^o 3 Section of 6x9 Subway with Face Boards & Back Laths used in Coast Sand Dunes
- N^o 4 Section 6x4 Tunnel Dig dug & banking used in Coast Sand Dunes
- N^o 5 (Description from label) Deep Dig dug with Steel Sets & Bankings 6x6 1/2 in the plain used in Gas Clay & Chalk
- N^o 6 Machine's gun complement arrangement of shaft used in Coast Sand Dunes.
- N^o 7 Spiral Stairway in 7" Diameter Well Tubing shaft used in Gas Clay & running ground (Description from label)

Only 6 Groups in books

Where from brought Date sent	and Globally Number CIVIL	Date	Received Date when	Received Place where	REMARKS etc. PARTICULARS OF EXHIBIT	Received Date	No. Receipt	No. Case
------------------------------------	------------------------------	------	-----------------------	-------------------------	--	------------------	----------------	-------------

PARTICULARS BOOK

PARTICULARS BOOK.

20 Bks. - 10/18 - 13367.

Date des- patched. Where from	GIVER and Trophy Number.	Unit	Date when Found.	Place where Found.	PARTICULARS OF EXHIBIT, FINDING, etc.	Date Entered.	Receipt No.	Case No.

101 255

April 1918 Appendix A No (XXIX)

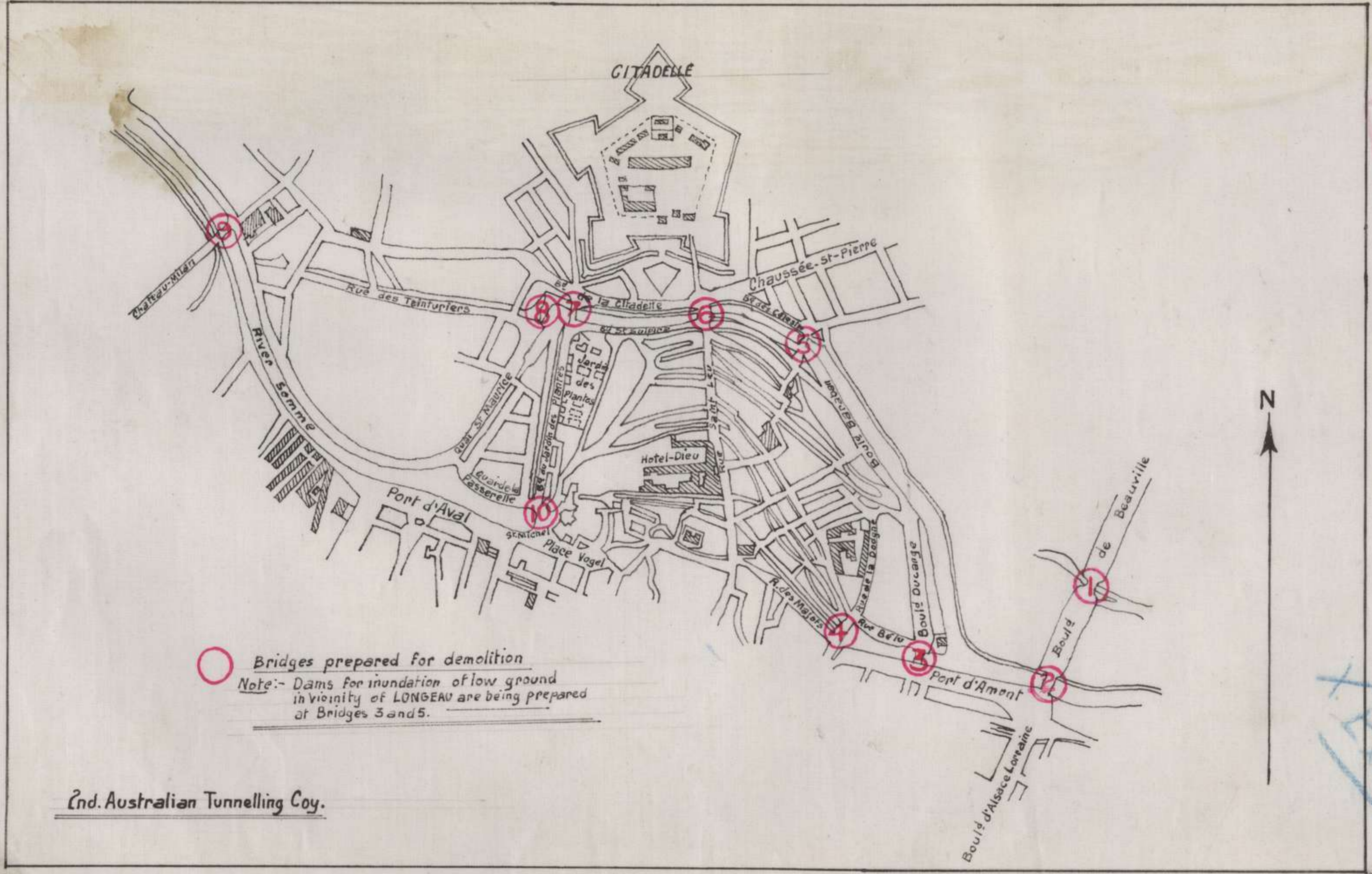

○ Bridges prepared for demolition
 Note:- Dams for inundation of low ground in vicinity of LONGEAU are being prepared at Bridges 3 and 5.

2nd. Australian Tunnelling Coy.

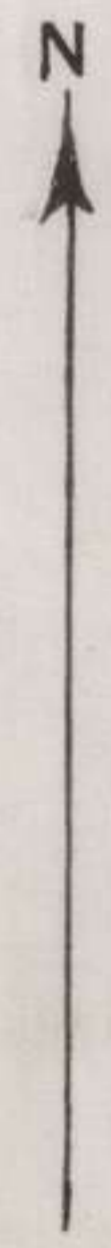

Handwritten blue scribbles or initials.

APPENDIX A. 99.

WAR DIARY. No. 2

AUSTRALIAN

PHOTOGRAPH of Section going up on Wiring on DEFENCE LINE

Date

79

APPENDIX

130

THE ANZAC BULLETIN.

5

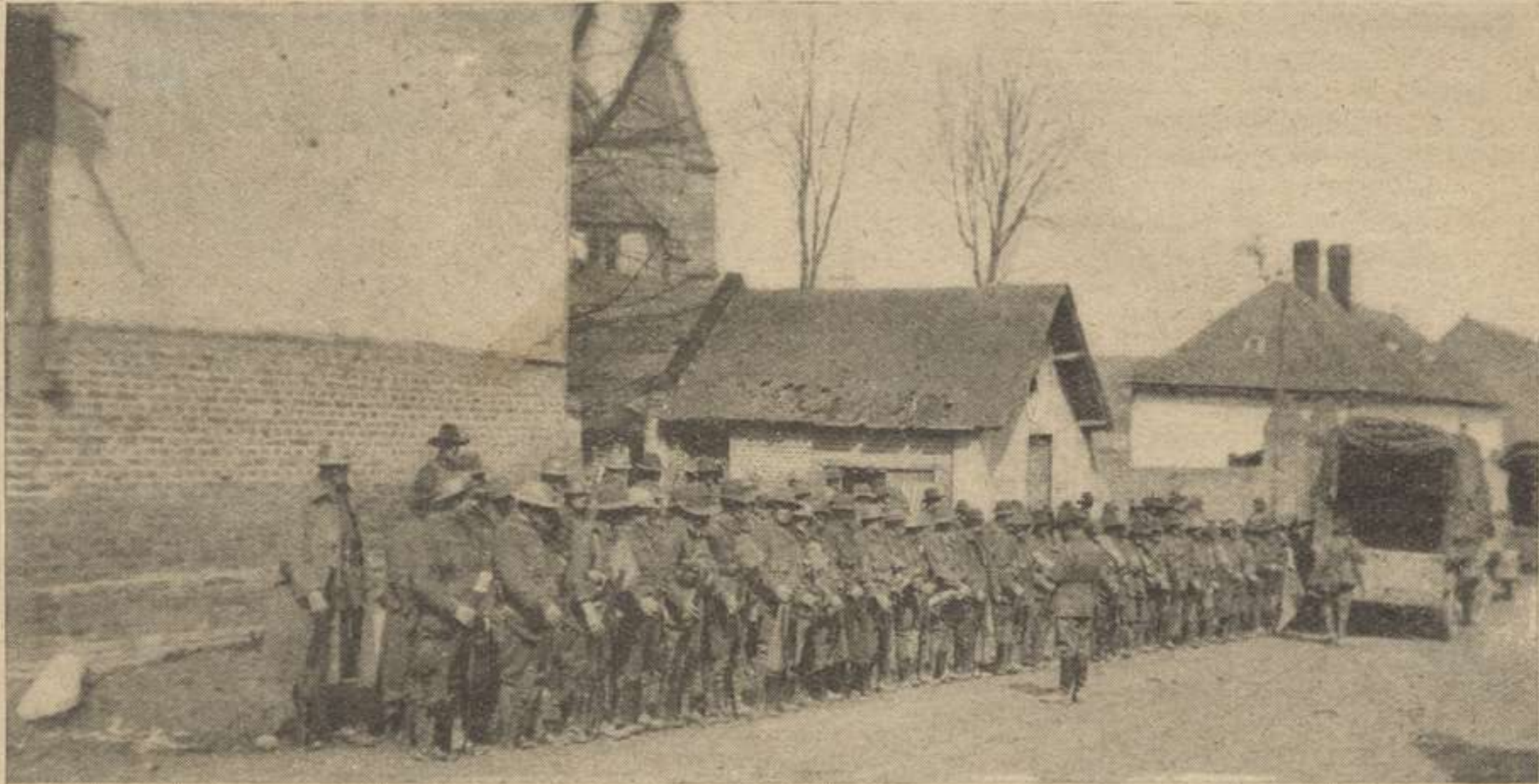

Australian Tunnelling Corps setting out to wire a new Defence Line.

(Australian Official Photograph.)

Anzac Bulletin.

April 36th. 1918.

FRANCE

FIRST EDITION

SHEET 62D

1:40,000

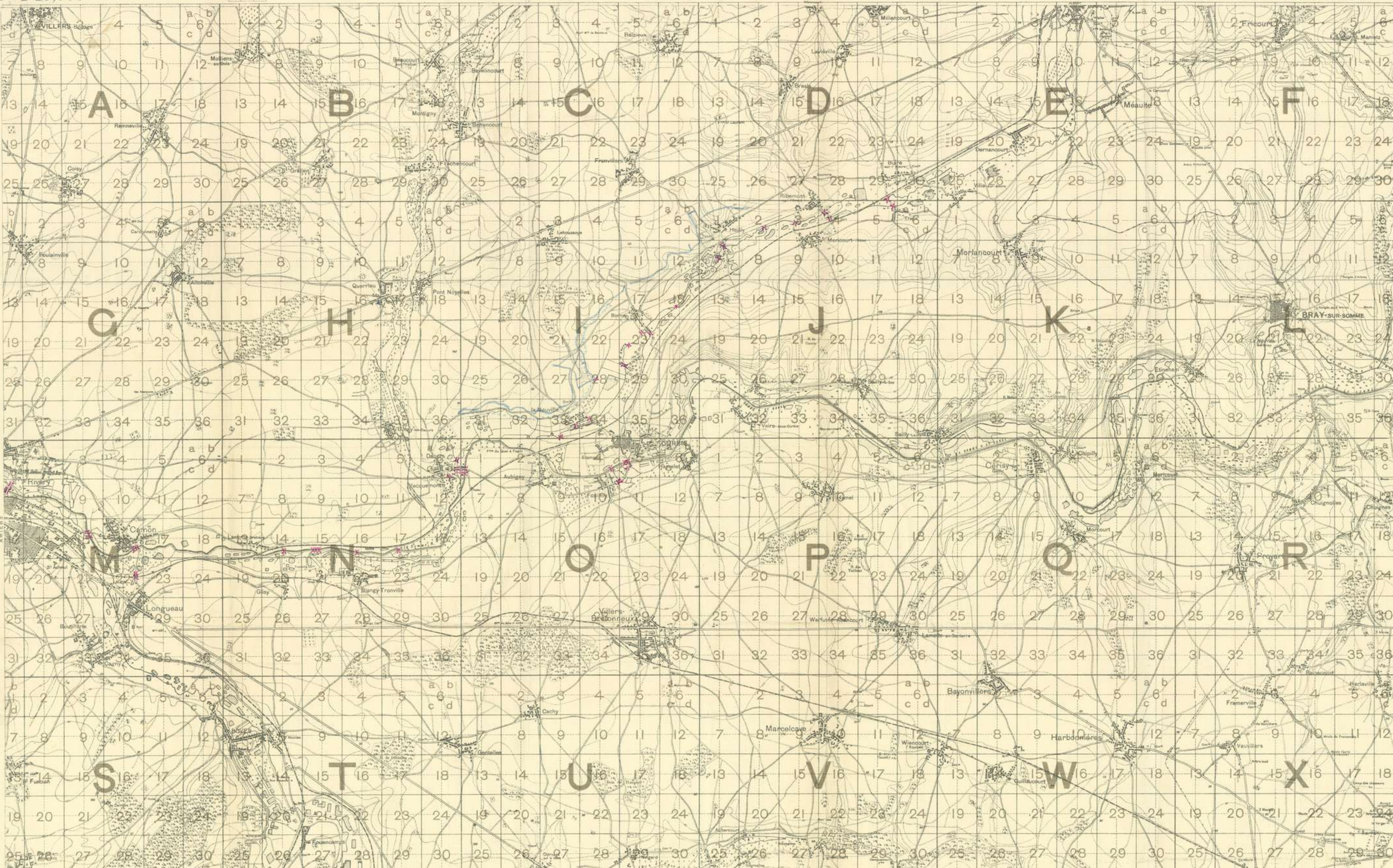

Changes shown on original plan.

2nd Australian Tunnelling Coy. War Diary - April 1916.

Map showing Bridges & Defence Line

Bridges -

Trenches -

Wiring -

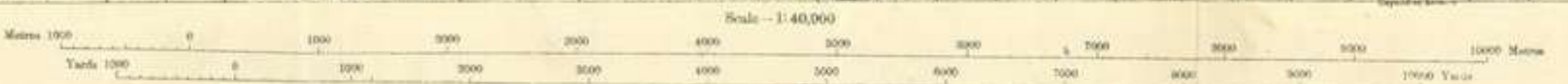

ALL HEIGHTS IN METRES.

X Extract
X 2 Copies
X Been

No. 1
AUSTRALIAN
TUNNELING CO.
No. _____
No. _____

Blank page with a small stamp at the bottom left.

YBBERDA W 27

C O N F I D E N T I A L .Statement of Repatriated Prisoner of War.Administrative Headquarters
Australian Imp. Force.
"B" Records Sec.

February 20th, 1918.

Reg. No. 3988.
Rank. Sapper.
Name. MINOGUE. P.
Unit. 2nd Australian Tunnelling Coy.

CIRCUMSTANCES OF CAPTURE.

- (a) Date. July 10th, 1917.
(b) Place. Nieuport.
(c) What happened before capture.

We Australian Tunnellers arrived in the Nieuport Sector from the Ypres Sector about June 29th 1917. We were put to making saps in the front line and building dugouts behind. There were three shifts of us employed - about 30 men to a shift. With others I was captured during the course of a German counter-attack on July 10. It was about 7 o'clock in the evening when the Germans actually came over. There was a canal behind us crossed by pontoon-bridges. It was that part of the canal just near its entrance to the sea. Before they came over to us the Germans had already shelled and destroyed these pontoon-bridges. The Germans who took us prisoners came across from in front of us, though I afterwards learned that there were Germans behind us when we were taken. We were all armed, each carrying rifle and bayonet and 80 rounds of ammunition. There had been a heavy enemy barrage in front of us. It lifted, and when we came out of the sap to see what was doing we found ourselves confronted by a body of German soldiers. They immediately opened on us with hand-grenades; I was not hurt, nor do I know any of our chaps that were hurt by these first bombs. I opened fire on the enemy with my rifle; we had no bombs. The Germans replied with hand-grenades. One bomb burst on my thigh, severely shattering it. I was badly wounded in ~~the~~ abdomen, my left ankle stopped a machine gun bullet, I was struck in the left arm by a revolver bullet, though the latter was not a wound of any consequence. Anyhow my "issue" was a pretty substantial "poultice". They had bropped me pretty heavy and I was completely out of action. The land was an area of sandy hillocks and I crawled into one of the hollows. I lay there till after-dark - about three hours, when some Germans came along and I was a prisoner.

What happened immediately after Capture.

The Germans placed me on a ground sheet and carried me back into the sap. They fixed up my wounds as ~~best~~ well as they could with the "first field dressing" that I carried on me. The Germans who had captured me appeared to be a machine gun section of Marines. I think all our chaps that were across the canal must have been captured. Our Red Cross advanced position across the canal at any rate fell into German hands. I was carried to a place not far behind the enemy lines called Middlekirke.

X Exh. 1

Account of Life as a Prisoner of War.

From Middlekirke I was conveyed by Motor-transport to Ostend. I remained there only one night, going on next day by ambulance waggon to Bruges. I was kept in Bruges for three months at the "No. 1 Marine Hospital". At any rate that was the marking on the blank X-ets, etc.,

The medical treatment at this hospital I can describe as "fair". The German Sisters treated us all right and the German doctors, too "gave us a fair spin". For six weeks I had a heavy weight hung on my wounded leg; at the end of that time the limb was put in plaster of Paris, They kept the strain on my leg until the plaster was taken off.

The food, however, at Bruges, was very poor. For the most part we were fed upon brown bread and a poor sort of "soup". Now and again we had a little jam.

From Bruges I was taken to a lazarette at Hamburg. There were never at any time while I was there more than four Australians in that lazarette. Among those whose names I can remember were Privates Hammell and Collett. These were both 4th Division men and from time to time they used to come and see me. I was a bed patient.

I remained at Hamburg till January 4th 1918. Then I was removed to a big prisoners camp at Gustrow. I only remained at that camp for three days. Apparently I had been taken there to be examined with a view to being exchanged. I passed the doctors there and was taken back to Hamburg. Thence I came to the frontier town of Aachen where I remained for these days and underwent another examination by German doctors.

From Aachen, with other returning Australian Prisoners of War, I crossed Holland to the port of Rotterdam. The Dutch people extended a splendid welcome, the Dutch sisters and nurses in particular, endeavouring to assist us in every way. At Rotterdam I embarked for England reaching Boston on January 20.

At Gustrow Camp there is an unwounded Australian sergeant working in the Post Office. I received no Red Cross parcels while I was a prisoner. You see I spent so great a part of my time in Bruges in Belgium and from Bruges, prisoners are not permitted to write letters carrying any address. In any case an Australian Prisoner of War is very lucky if he receives his first Austrian Red Cross parcel inside three months.

In Bruges the hospital appears to have been at one time a convent. In this institution the scrubbing of the corridors was done by Belgian women, but I cannot say whether they were paid for their work or not. At Hamburg the medical attention was very poor; there was only one old civilian doctor. The bandages used were of paper. These bandages were alright unless applied to a running wound, in which case they soon become "soppy".

At Bruges I saw Walter Young of my Company. He left Bruges seven weeks before me to go to Gustrow, but I found out there afterwards that he had been sent back to Belgium to work.

At first the Germans seemed greatly surprised to learn that I was an Australian. They cannot understand Australians taking part in the War. They do not understand our having volunteered and have not much time for us on that account. They can understand- and they prefer- conscripts.

(Signed). P. MINOGUE.

X Enhanced

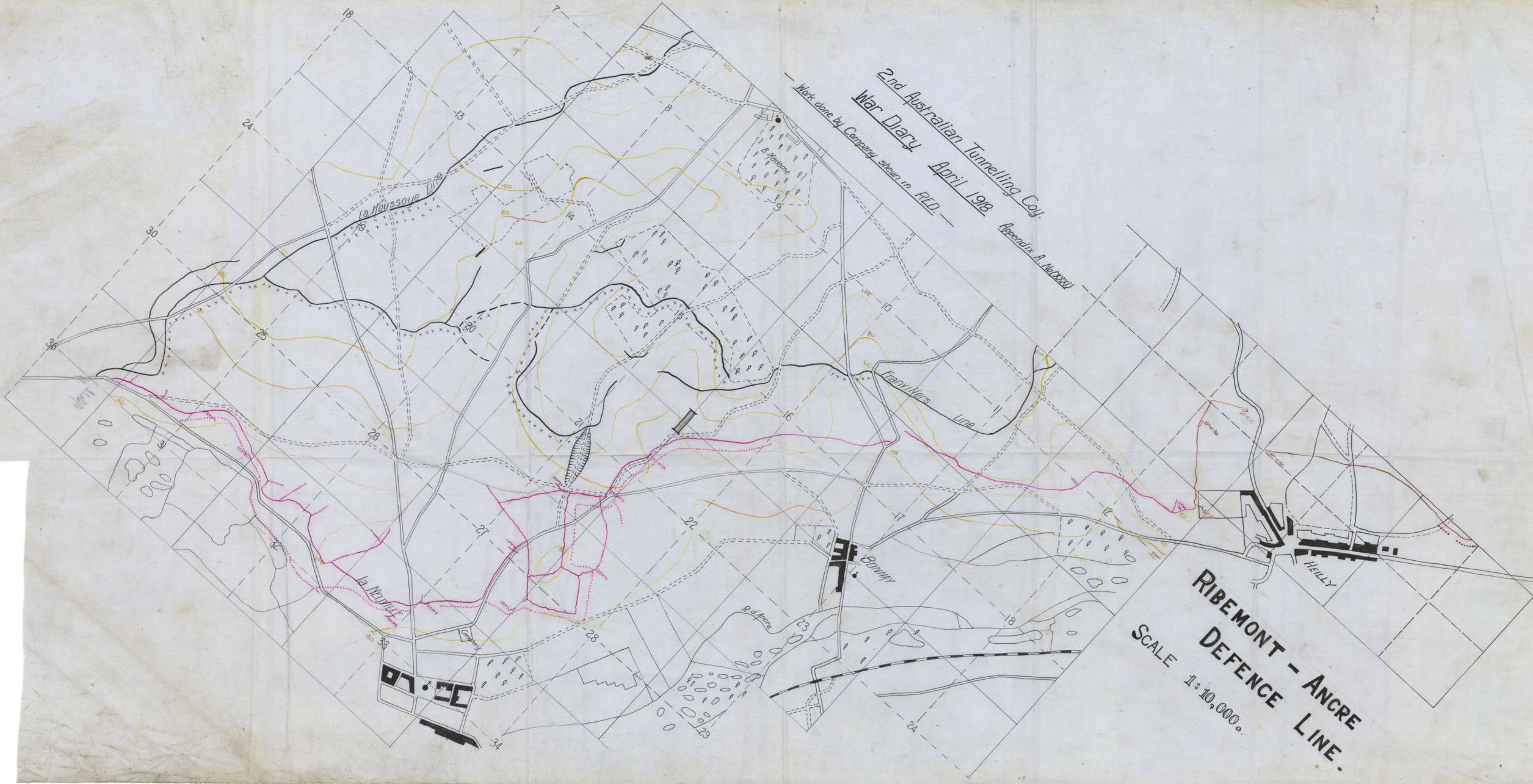

2nd Australian Tunnelling Coy.
War Diary April 1918
Appendix A No. XXXI
— Work done by Company shown in RED —

RIBEMONT - ANCRE
DEFENCE LINE.
SCALE 1:10,000.

RIBEMONT - ANCRE
DEFENCE LINE
SCALE 1:10,000

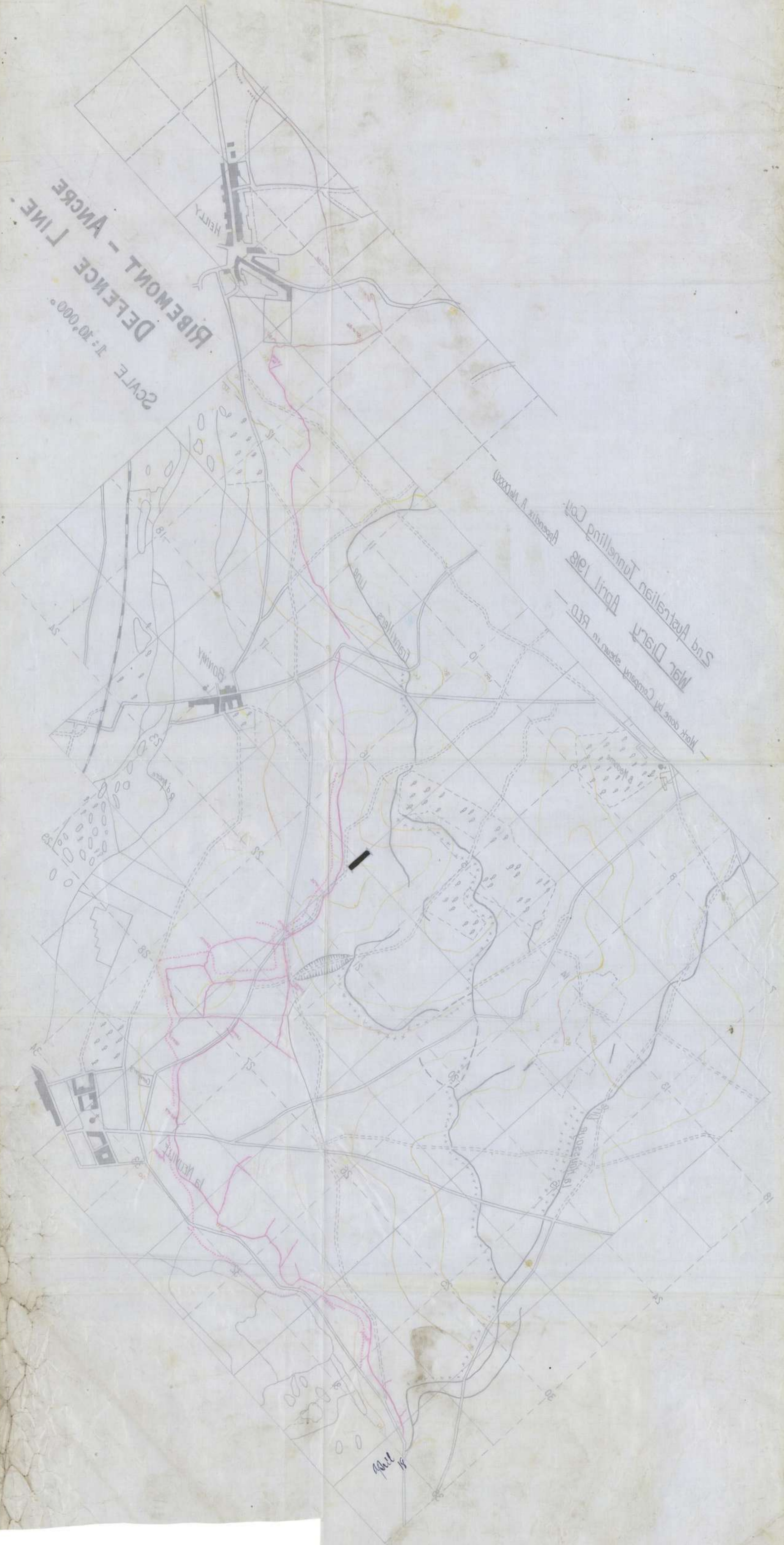

Work done by Company shown in RED.
War Diary April 1918
2nd Australian Tunnelling Coy.
Appendix A (Map)

April 18

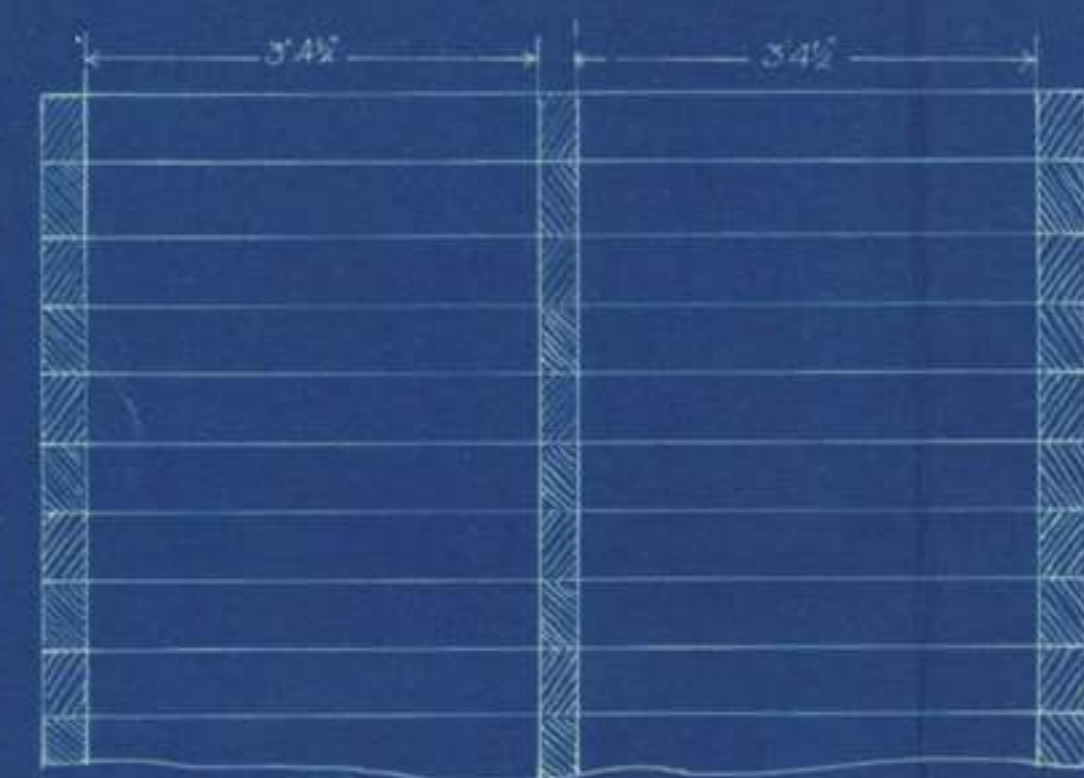
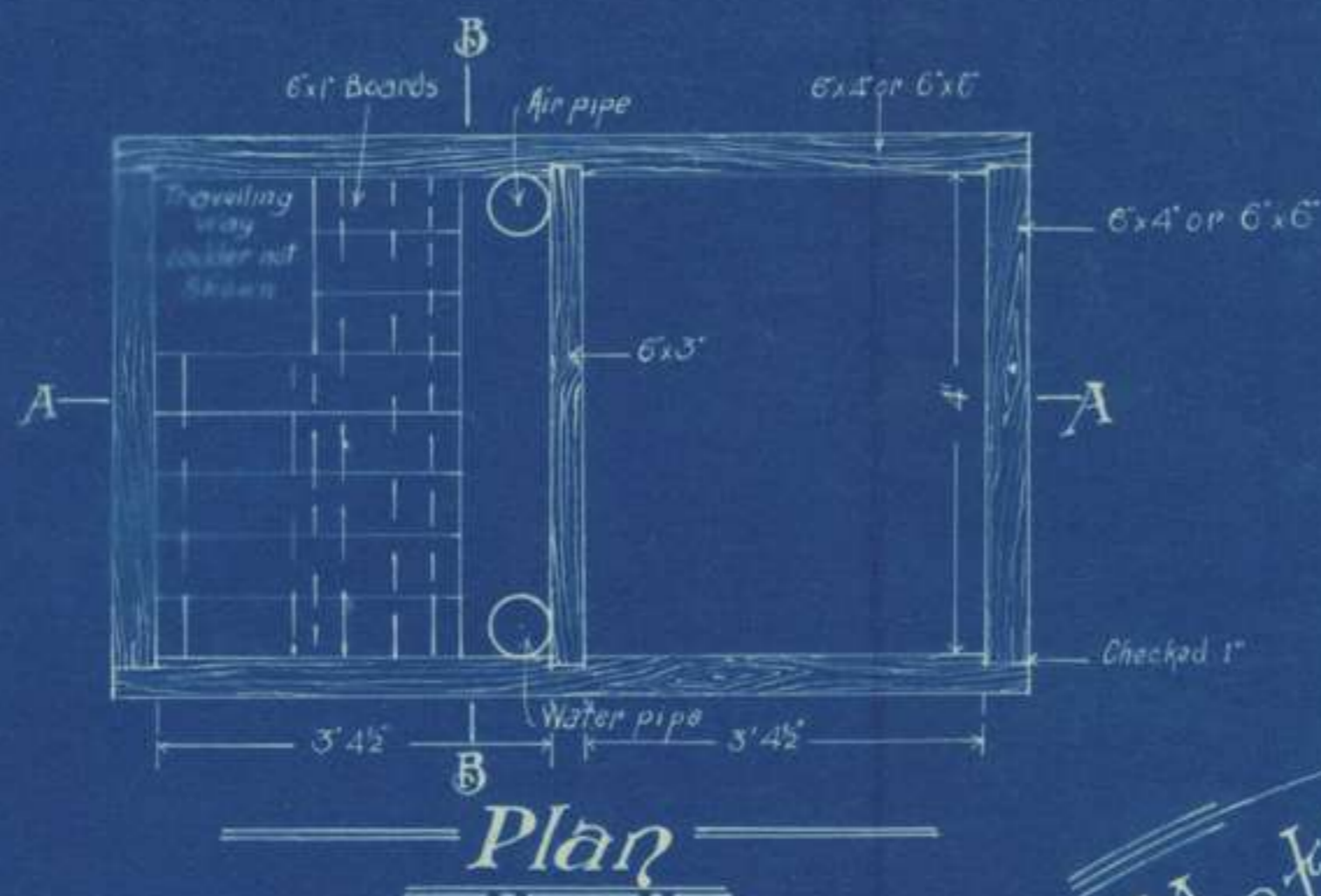

Elevation A.A.
(for wet ground)

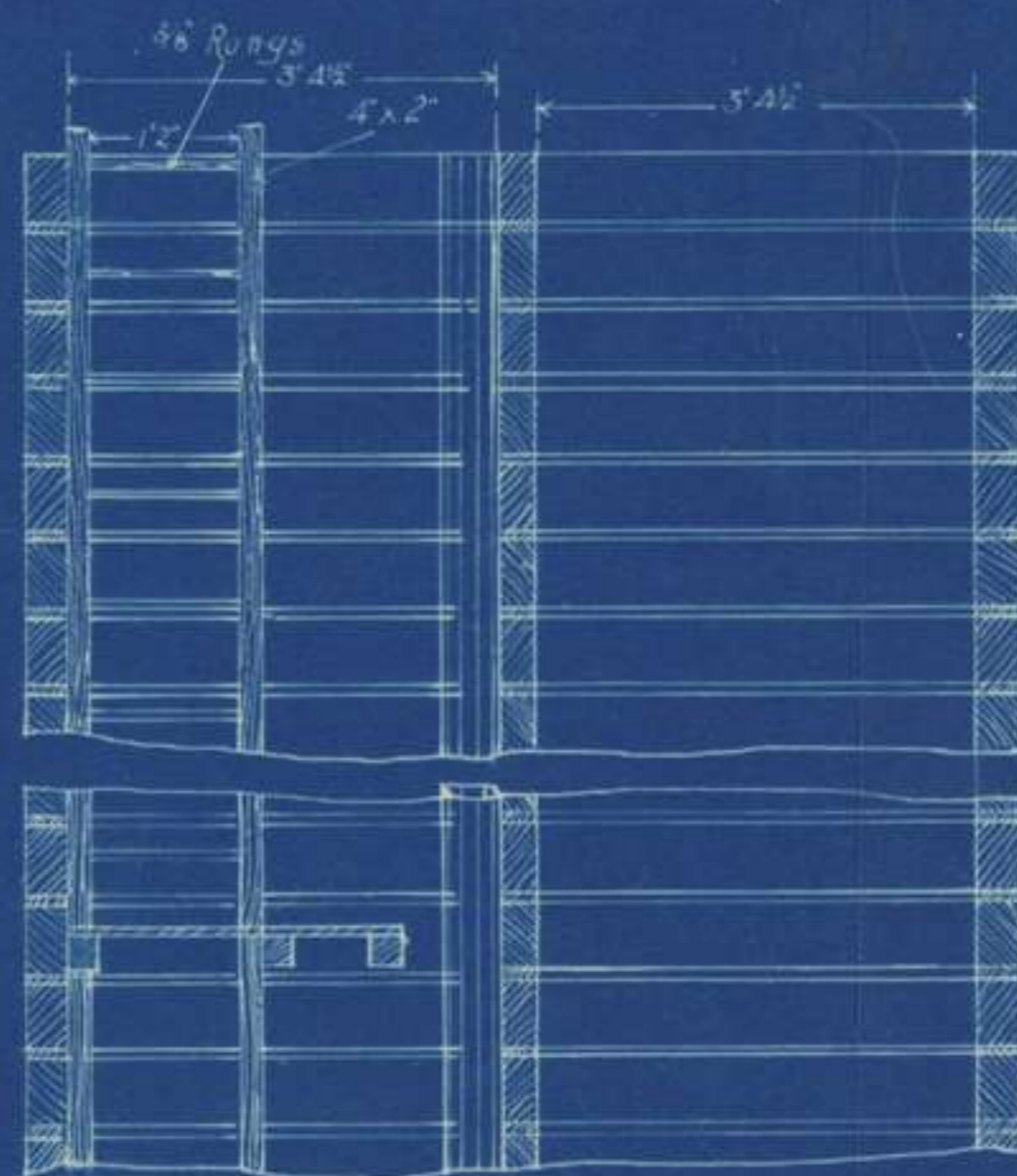

Elevation A.A.
(for clay)

Method of Timbering
for Deep Shafts
in Wet Ground & Clay
Scale 1/2" = 1'
2nd. Australian Tunnelling Coy.

WAR DIARY APRIL 1918 Appendix (50)

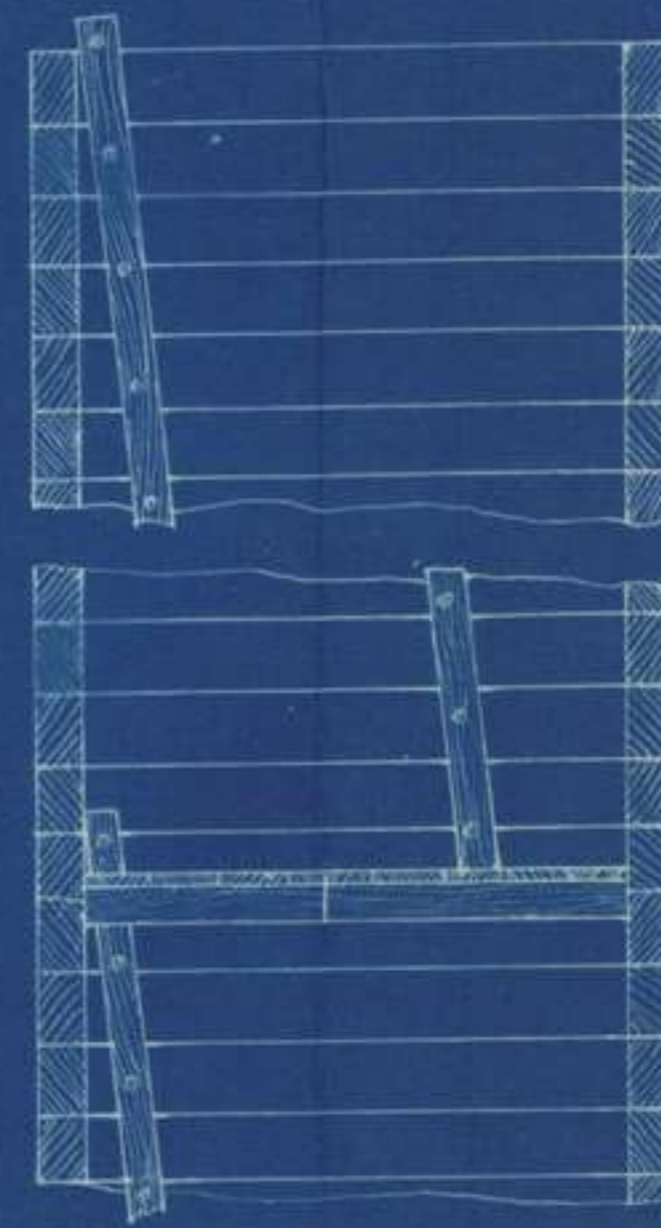

Cross Section B.B.
Showing arrangement
of ladders

Ap - XV3