

# Corian® Specification Sheet : 3213 Washplane

[Revised November 2019]

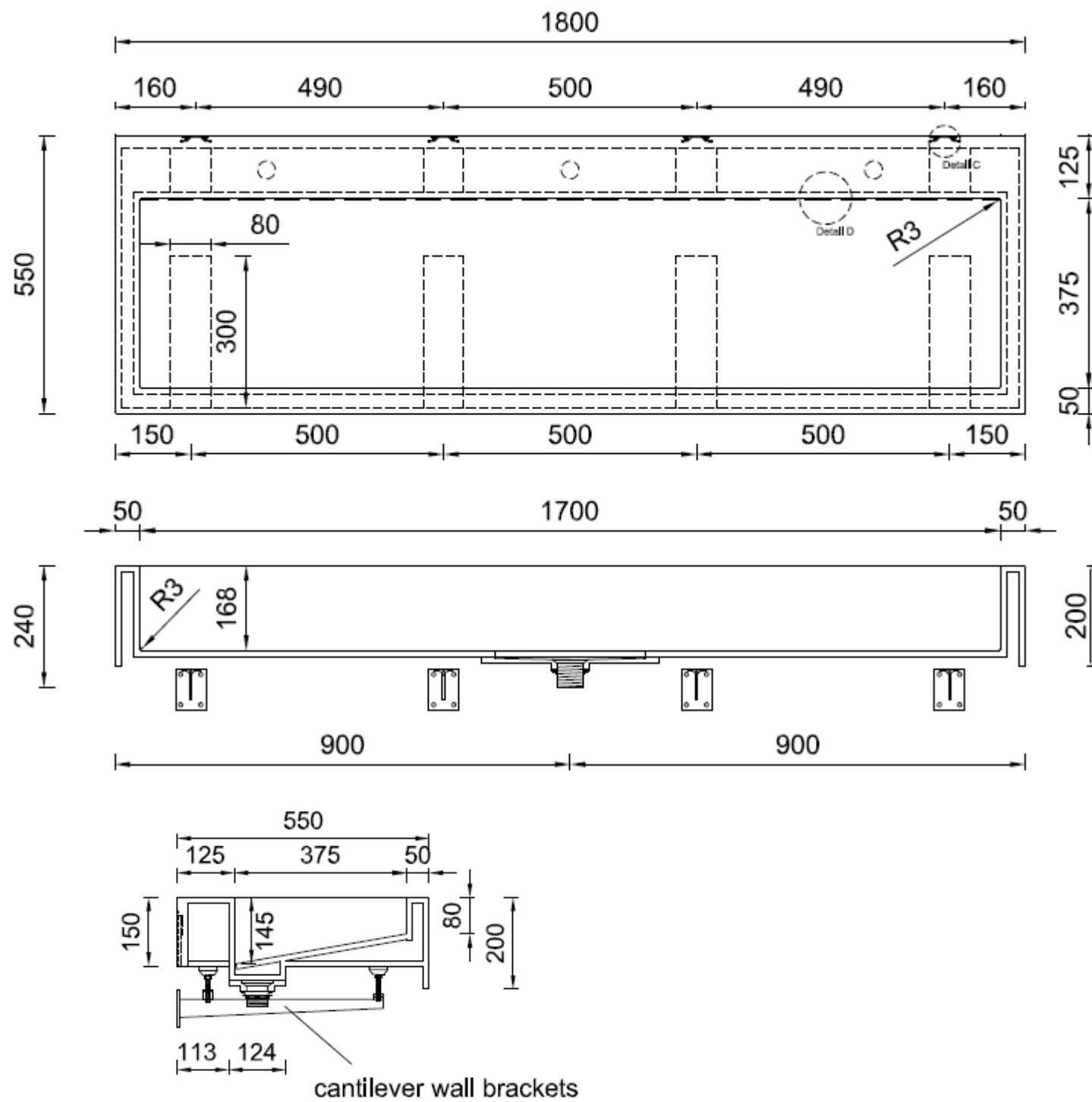

## Notes:

- Tap hole cutouts not included, drawing for location reference only.
- All external edges sanded to 2mm radius
- Top surface sanded to semi-gloss finish

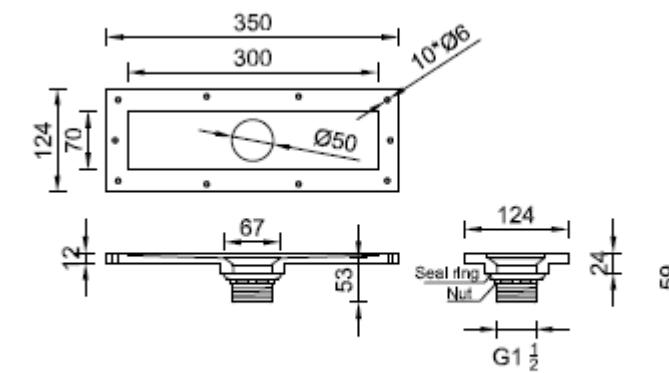
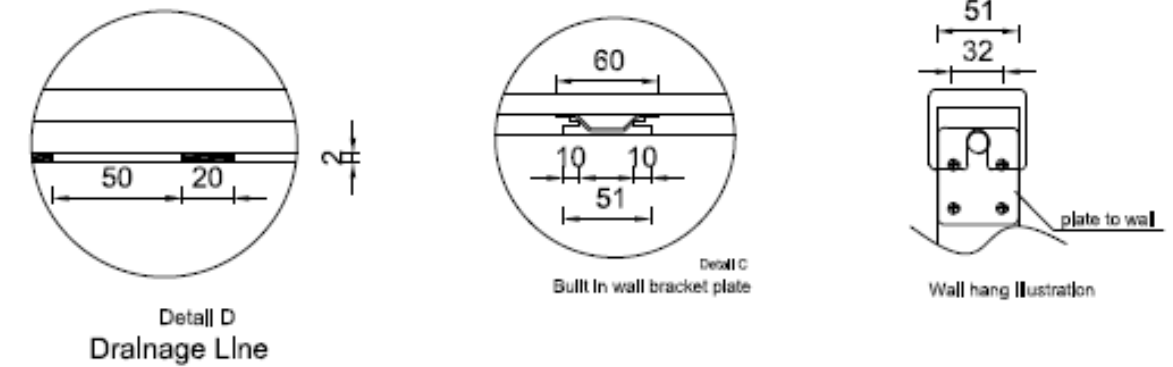

Waste Kit

6	1 plywood wall bracket template
5	4 wall bracket fixing plates & screws
4	4 x 450mm adjustable cantilever wall brackets & screws
3	1 waste fitting, pre-assembled to #2
2	1 Corian waste kit, pre-assembled to #1
1	1 Corian Washplane 3213
#	Packing List

CASF Australia  
 Unit 3, 208 Walters Road, Arndell Park NSW 2148  
 Tel: 1300 795 044  
 Email: projects@casf.com.au

**casf**  
 your space your way

**CORIAN®**  
 SOLID SURFACE