

# C540

## MAIN SPECIFICATIONS

<b>ENGINE</b>	CUMMINS QSK19 LITRE 650 LTA PRODUCING 650 HP AND 2275 LB-FT TORQUE
<b>TRANSMISSION</b>	MID-MOUNTED ALLISON H6610 6 SPEED AUTOMATIC WITH SEPARATE COOLING SYSTEM AND RETARDER
<b>STEER AXLE</b>	DANA EFA24 10 TONNE CAPACITY
<b>DRIVE AXLE</b>	AXLETECH SPRC 2197 50 TONNE CAPACITY
<b>REAR SUSPENSION</b>	HENDRICKSON R1000
<b>TYRES</b>	MICHELIN 385/95R25
<b>RIMS</b>	TITAN 10 X 25
<b>ROPS/FOPS</b>	ALL INDUSTRIES GROUP

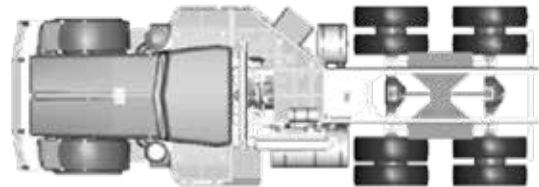
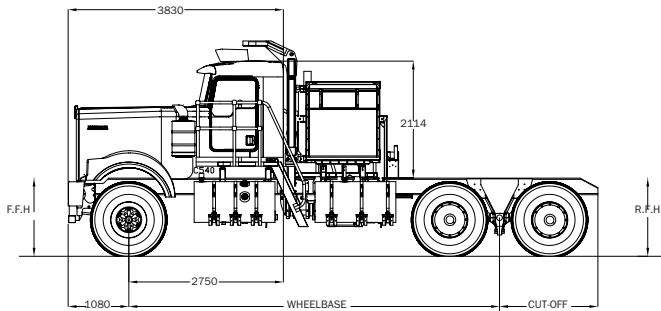

### Front Frame Height (F.F.H.) mm - Unladen

	Tyres
<b>Front Spring</b>	<b>385/95 R25 XMH</b>
<b>10T Taper</b>	1410

### Rear Frame Height (F.F.H.) mm - Unladen

	Tyres
<b>Rear suspension</b>	<b>385/95 R25 XMH</b>
<b>Hendrickson R1000</b>	1360

\*C540 - 295mm frame rail

#### IMPORTANT NOTES

All frame height dimensions are to the top of the frame using 295mm rails.

For illustration purposes different configurations have been used.

Variations will occur due to tare weight differences caused by optional equipment and fuel. Variations of +/- 25mm can be expected on heavy duty trucks.

Heights have been calculated with the tyre in an unladen condition and unless specified Bridgestone tyres have been used in the calculations. Variations will be caused by different tyre manufacturers.

For a wide range of options, contact your Kenworth Dealer.

PACCAR Australia Pty Ltd,  
64 Canterbury Road,  
Bayswater, Victoria 3153  
Phone (03) 9721 1500

[www.kenworth.com.au](http://www.kenworth.com.au)



**AUSTRALIAN MADE. WORLD'S BEST.**