



TOGETHER ON THE ROAD

International



PROSTAR DAY & EXTENDED CAB

Regional to Long-Haul Applications • Single Trailer or B Double • Fleet or Owner Operator

The INTERNATIONAL® ProStar is an innovative and efficient highway truck, with class leading aerodynamics and advanced Cummins® engine technology. Combined with a cab that is designed for greater comfort, visibility and driver control, and a short BBC to fit a wide range of applications, it will keep your business running at its best.

PROStar

PROSTAR DAY & EXTENDED CAB

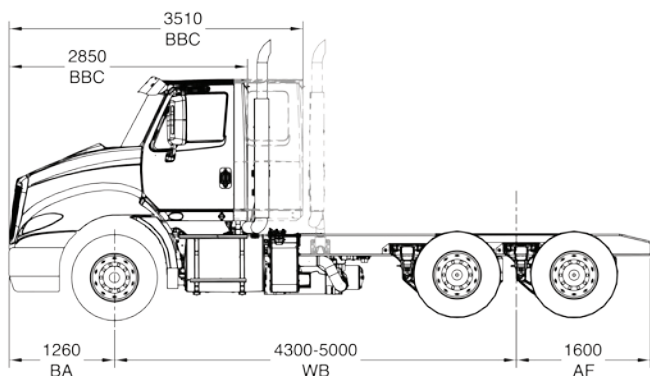

KEY FEATURES

- ▶ Compact 112" BBC Day Cab for optimised weight distribution and operational flexibility
- ▶ Advanced aerodynamics and powertrain for improved fuel economy
- ▶ Short sloping hood and large curved windscreen provide excellent forward visibility and safety
- ▶ LED headlamps with integrated daytime running lamps for safety and visibility, day and night
- ▶ Ergonomic cab designed for the driver with optimised switch and controls placement
- ▶ Three-point cab suspension system for a comfortable ride with reduced noise, vibration and harshness
- ▶ Wide-track front axle for a tighter turning radius and better maneuverability
- ▶ Bendix® ABS with Automatic Traction Control improves safety and reduces tyre wear
- ▶ Effort-reducing air over hydraulic clutch provides excellent feel with reduced driver fatigue*
- ▶ Simple electrical system architecture and improved harnessing to maximize uptime

112" BBC 6 X 4

GVM / GCM

24.5 tonne / 90.0 tonne

- Higher GCM ratings are available subject to application approval

INTERNATIONAL PROSTAR TARE WEIGHTS				
Spec	WB (mm)	Steer Weight (kg)	Drive Weight (kg)	Total Weight (kg)
Day Cab	4300	4500	3630	8130
Tipper	5000	4530	3650	8180
Ext. Cab	4700	4580	3720	8300

Weights include all fluids, minimum fuel, and std. alloy front bumper.

CAB CONFIGURATIONS / BBC

- ▶ Day Cab / 2850 mm (112")
- ▶ Extended Cab / 3510 mm (138")

CAB FEATURES

- ▶ 2085 mm (82") wide ECE-R29 compliant cab structure
- ▶ 660 mm (26") wide bunk (with extended cab)
- ▶ High strength zinc coated steel with e-coat primer
- ▶ Large curved, wrap-around windshield
- ▶ Leather air suspended driver and passenger seat
- ▶ Stainless steel exterior sunvisor
 - Optional cab side extenders and roof fairings

WHEELBASE OPTIONS

4.30 - 5.00 m

- Other wheelbase options available upon request

FRAMES

- ▶ Heat treated alloy steel, 825 MPa (120,000 psi) yield strength
 - Dimension: 260 x 92 x 9.5 mm. Section modulus: 291 cm³
- ▶ Heavy duty cross-members
- ▶ Multiple aluminium bumper and bull bar options available, all with integrated front under-run protection

BRAKES

- ▶ Air drum brakes, ABS with automatic traction control
- ▶ Hill start aid (with UltraShift® PLUS)

POWER STEERING

- ▶ Sheppard M100 steering gear
- ▶ Tilt telescopic steering column

EXHAUST SYSTEM

- ▶ Dual vertical exhausts, frame mounted, with stainless steel guards
- ▶ Frame mounted horizontal SCR after-treatment device

COOLING SYSTEM

- ▶ Over and under system, CAC above radiator
- ▶ 1.0 m² (1545 in²) total package size
- ▶ Horton drivemaster air operated two speed fan drive

ENGINE

- ▶ Cummins® X15: 410 kW (550 hp) / 2508 Nm (1850 lb.-ft.)
 - Other ratings available upon request
- ▶ ADEPT powertrain technology (optional with UltraShift® PLUS)

TRANSMISSIONS

- ▶ Eaton® RTLOF-20918B 18-speed manual
- ▶ Eaton® UltraShift® PLUS 18-speed automated manual
 - All transmission include filter and oil to air cooler

DRIVESHAFT

Dana® SPL250XL main, SPL170XL inneraxle

REAR AXLE

- ▶ Meritor tandem: RT46-160GP 20,900 kg
- ▶ Power divider lock with cross locks on both axles
- ▶ Aluminium alloy hubs

REAR SUSPENSION

Hendrickson Primaax-EX air tandem: 20,900 kg

FRONT AXLE

- ▶ Meritor MFS 14-143A wide track: 6500 kg
- ▶ Aluminium alloy hubs

FRONT SUSPENSION

Parabolic taperleaf: 3 leaf, 6500 kg

FUEL TANKS

- ▶ Dual, polished aluminium, 660 mm (26") diameter
 - 320 L LHS, 320 L RHS, 640 L total tank volume (with 4.3 m WB)
 - 320 L LHS, 400 L RHS, 720 L total tank volume (except with 4.3 m WB)
- ▶ 90 L AdBlue tank, LHS

ELECTRICAL SYSTEM

- ▶ 10 gauge instrument cluster, 2 gauge axillary cluster
- ▶ 12 V 160 ampere alternator
- ▶ 3 x 12 V 2775 CCA batteries
- ▶ LED headlamps, parking lamps, turn indicators and brake lamps
- ▶ LED daytime running lamps
- ▶ Exterior light check switch for pre-trip inspection
- ▶ PTO switch, wiring, and air solenoid
- ▶ Circuit breakers - manual reset
- ▶ Park brake warning alarm
- ▶ Optional 6.1" touch screen multimedia system, with navigation

WHEELS AND TYRES

- ▶ Alloy wheels, polished, 10 stud 285 mm PCD, 8.25DC x 22.5
- ▶ Steer tyres: 295/80R22.5; drive tyres: 11R22.5

* With manual transmission