



TOGETHER ON THE ROAD

International



PROSTAR SLEEPER

Regional to Long-Haul Applications • Single Trailer or B Double • Fleet or Owner Operator

The INTERNATIONAL® ProStar is an innovative and efficient highway truck, with class leading aerodynamics and advanced Cummins® engine technology. Combined with a cab that is designed for greater comfort, visibility and driver control, and a short BBC to fit a wide range of applications, it will keep your business running at its best.

PROStar

PROSTAR SLEEPER

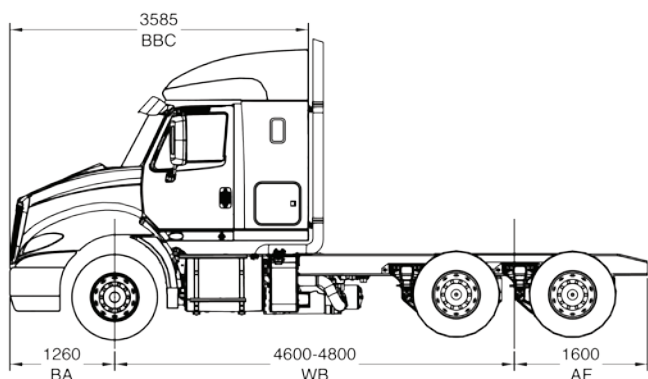

141" BBC 6 x 4

GVM / GCM

24.5 tonne / 90.0 tonne

- Higher GCM ratings are available subject to application approval

| INTERNATIONAL PROSTAR TARE WEIGHTS | | | | |
|------------------------------------|---------|-------------------|-------------------|-------------------|
| Spec | WB (mm) | Steer Weight (kg) | Drive Weight (kg) | Total Weight (kg) |
| Sleeper Cab | 4700 | 4750 | 3790 | 8540 |

Weights include all fluids, minimum fuel, and std. alloy front bumper.

CAB CONFIGURATIONS / BBC

40" Integrated sleeper cab* / 3585 mm (141") BBC

CAB FEATURES

- 2085 mm (82") wide ECE-R29 compliant cab structure
- 2250 mm wide sleeper with 2170 x 700 mm inner-spring mattress
- Wrap-around windshield with stainless steel exterior sunvisor
- Leather air suspended driver and passenger seats
- Large under-bunk storage with internal and external access
- Bunk curtains behind seats and around window glass area
- Overhead console with storage shelf
- Cab side extenders
 - Optional roof fairing

WHEELBASE OPTIONS

4.60 - 4.80 m

- Other wheelbase options available upon request

FRAMES

- Heat treated alloy steel, 825 MPa (120,000 psi) yield strength
 - Dimension: 260 x 92 x 9.5 mm. Section modulus: 291 cm³
- Heavy duty cross-members
- Multiple aluminium bumper and bull bar options available, all with integrated front under-run protection

BRAKES

- Air drum brakes, ABS with automatic traction control
- Hill start aid (with UltraShift® PLUS)

POWER STEERING

- Sheppard M100 steering gear
- Tilt telescopic steering column

EXHAUST SYSTEM

- Dual vertical exhausts, cab mounted, with stainless steel guards
- Frame mounted horizontal SCR after-treatment device

COOLING SYSTEM

- Over and under system, CAC above radiator
- 1.0 m² (1545 in²) total package size
- Horton drivemaster air operated two speed fan drive

KEY FEATURES

- Compact 141" BBC Sleeper Cab designed for long haul B-Double applications
- Advanced aerodynamics and optimised drivetrains for improved fuel economy
- Short sloping hood and large curved windshield provide excellent forward visibility and safety
- LED headlamps with integrated daytime running lamps for safety and visibility, day and night
- Ergonomic cab designed for the driver, with optimised switch and controls placement
- Three-point cab suspension system for a comfortable ride with reduced noise, vibration and harshness
- Full height integrated sleeper compartment with generous storage space and fridge provision
- Wide-track front axle for a tighter turning radius and better maneuverability
- Bendix® ABS with Automatic Traction Control improves safety and reduces tyre wear
- Effort-reducing air over hydraulic clutch provides excellent feel with reduced driver fatigue*

ENGINE

- Cummins® X15: 410 kW (550 hp) / 2508 Nm (1850 lb.-ft.)
 - Other ratings available upon request
- ADEPT powertrain technology (optional with UltraShift® PLUS)

TRANSMISSIONS

- Eaton® RTLOE-209188 18-speed manual
- Eaton® UltraShift® PLUS 18-speed automated manual
 - All transmissions include filter and oil to air cooler

DRIVESHAFT

Dana® SPL250XL main, SPL170XL inneraxle

REAR AXLE

- Meritor tandem: RT46-160GP 20,900 kg
- Power divider lock with cross locks on both rear axles
- Aluminium alloy hubs

REAR SUSPENSION

Hendrickson Primaax-EX air tandem: 20,900 kg

FRONT AXLE

- Meritor MFS 14-143A wide track: 6500 kg
- Aluminium alloy hubs

FRONT SUSPENSION

Parabolic taperleaf: 3 leaf, 6500 kg

FUEL TANKS

- Dual, polished aluminium, 660 mm (26") diameter
 - 320 L LHS, 400 L RHS, 720 L total tank volume
 - Additional fuel tank options available upon request
- 90 L AdBlue tank, LHS

ELECTRICAL SYSTEM

- 10 gauge instrument cluster, 2 gauge axillary cluster
- 12 V 160 ampere alternator
- 3 x 12 V 2775 CCA batteries
- LED headlamps, parking lamps, turn indicators and brake lamps
- LED daytime running lamps
- Exterior light check switch for pre-trip inspection
- 2 x LED work lamps
- Circuit breakers - manual reset
- Park brake warning alarm
- 2 x 12 V accessory sockets, circulating fan and reading lamps in sleeper
- Electrically adjustable heated mirrors
- Optional 6.1" touch screen multimedia system, with navigation

WHEELS AND TYRES

- Alloy wheels, polished, 10 stud 285 mm PCD, 8.25DC x 22.5
- Steer tyres: 295/80R22.5; drive tyres: 11R22.5

* With manual transmission