

ACCO 4 x 2



BUILDING AND SERVICING
AUSTRALIA FOR OVER 40 YEARS

IVECO

ACCO 4 x 2



ERGONOMICS

- LARGE NON-SLIP SELF-CLEANING CAB STEPS
- THREE POINT CONTACT FOR CAB INGRESS AND EGRESS
- INTERNAL CAB LAYOUT READY FOR APPLICATION SPECIFIC FIT-OUT
- 3/4 SIDE WINDOW FOR SIDE LOADER APPLICATIONS



PRODUCTIVITY

- LOW TARE WEIGHT
- OPTIMISED WEIGHT DISTRIBUTION FOR ALL APPLICATIONS
- LONG LIFE CYCLE



STRENGTH

- OVER 40 YEARS OF OPERATING IN THE MOST DEMANDING APPLICATIONS TO MEET TODAY'S REQUIREMENTS
- SOLID STEEL CAB CONSTRUCTION
- HEAVY DUTY CAB TRIM



VERSATILITY

- FACTORY FITTED DUAL CONTROL
- SPECIFIC BODY BUILDER CHASSIS DRILLINGS
- SPECIFIC CHASSIS LAYOUTS TAILOR MADE FOR BODY BUILDERS



AUSTRALIAN MADE

- DESIGNED, ENGINEERED AND MANUFACTURED IN AUSTRALIA
- CONSTRUCTED WITH LOCALLY SOURCED CONTENT



P E R F O R M A N C E

CUMMINS 8.9 LITRE ISL EURO 5 ENGINE

280HP AND 778 LB FT OF TORQUE

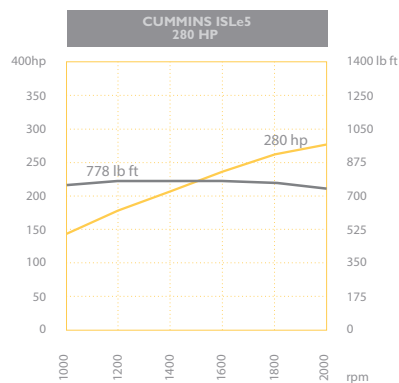

ENGINE Cummins ISL Euro 5 (ADR 80/03)

Maximum Output	280hp/209kW @ 2100rpm	Total Displacement	8.9 litres
Maximum Torque	778lb ft/1055Nm @ 1300rpm	Exhaust	Vertical exhaust catalyst on RHS with perforated heat shield Engine exhaust brake
Emissions Technology	Selective Catalytic Reduction (SCR)	Optional	Centrifuge oil spinner
Air Filter	Donaldson Radial Seal 381mm dry element air cleaner with safety element		



S T R E N G T H & V E R S A T I L I T Y

FACTORY FITTED DUAL CONTROL
SOLID STEEL CAB CONSTRUCTION
HEAVY DUTY CAB TRIM



W A R R A N T Y

24 MONTHS* / 500,000 KM / 6,000 HOURS / 100% PARTS AND LABOUR

This warranty commences on the earlier of the date of delivery of the truck to the Purchaser or the date of registration of the Vehicle.
This warranty ends on the earliest of the expiry of the duration, kilometres or hours.

#Acco Vehicles used off highway for 10% or more of total usage by kilometres will be covered by a 12 month duration warranty only.

Terms and Conditions apply, please see www.iveco.com.au for further details.

ACCO 4 x 2

CHASSIS DIMENSIONS (mm)

WB	AF	L	Turning Circle*
4400	1235	7148	16982
4600	1720	7833	17582
4800	1200	7513	18184
5000	1200	7713	18786
5200	1200	7913	19390
5200	1720	8433	19390
5500	1270	8283	20294
5500	1440	8453	20294

*For unladen cab-chassis. For wall-to-wall turning circle add 1740 mm. Refer to Bodybuilder diagrams for fuel tank lengths, locations and further details.

MASS RATINGS

- GVM 16.5 tonnes
- GCM 30 tonnes
- Chassis mass front 4.0 tonnes*
- Chassis mass rear 2.0 tonnes*
- Chassis mass total 6.0 tonnes*

*Chassis with oil and coolant, but no fuel, spare wheel or tyre. All weights calculated based on 4.4m wheelbase single control spec. (All weights and measurements are approximate only).

FRONT AXLE & SUSPENSION

- Meritor FG94I

Axle Type: Forged steel I-beam

Capacity: 6.6 tonnes

Optional: Hendrickson Steertek axle with Airtex suspension, convolute leaf spring and shock absorbers with drum brakes

Capacity: 6.6 tonnes

Suspension Type: Heavy duty multi leaf springs and double acting shock absorbers

Capacity: 6.7 tonnes

Optional: Heavy duty parabolic steel springs

Capacity: 6.7 tonnes

REAR AXLE & SUSPENSION

- Meritor RS23-161

Capacity: 11.0 tonnes

Ratio: 4.89

Optional: Driver controlled differential lock

Suspension Type: Hendrickson Primaax PAX232 (Air)

Capacity: 10.5 tonnes

BRAKES

Type: 2-circuit air system

Front & Rear: Drum brakes with automatic slack adjusters, park brake on steer and drive axles, brake exhaust silencers

- Bendix 4 channel ABS with Active Traction Control (ATC)
- Bendix air dryer
- Steel air tanks

Optional: Aluminium air tanks

STEERING

- Sheppard M110 power-assisted with gear driven pump, adjustable steering column and 470mm steering wheel

Optional: Dual Control steering (non-adjustable steering columns)

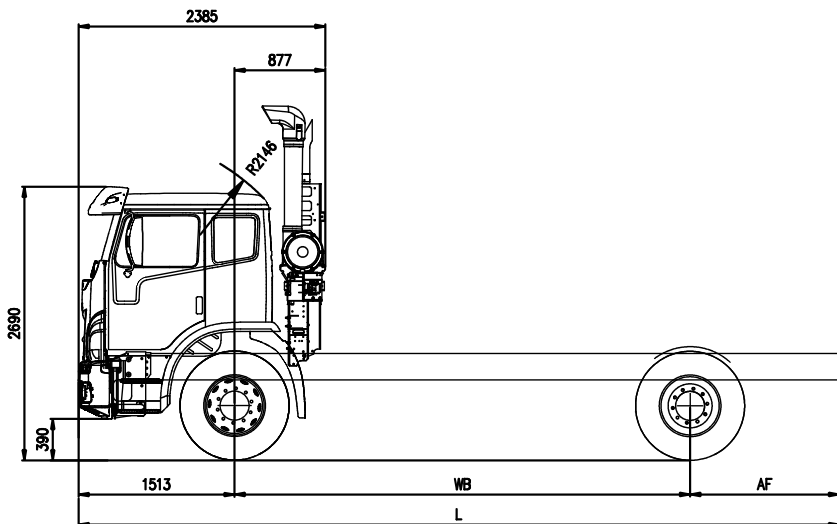

FUEL SYSTEM

- 1 x 285 litre square alloy fuel tank
- 1 x 27 litre AdBlue tank
- Fuel Pro fuel filter

TRANSMISSION

- Allison Gen 5 3000 series 6 speed automatic
- PowAuto PA38 (1.16:1) 650Nm hot shift transmission mounted PTO with mounting support bracket

CHASSIS

Type: 257x89x8mm parallel-section high tensile steel channel

- Heavy duty centrally mounted front towing pin
- Square end of frame
- Three piece steel bumper
- FUPS
- Reverse buzzer

Optional: Inverted L reinforcement on selected wheelbase for applications requiring additional frame reinforcement

ELECTRICAL SYSTEM

Type: 12 Volt

Batteries: 3 x N50 – 70A

Optional: 3 x N70 – 90A

Alternator: 12 Volt 170A 2 pole isolation switch

COOLING SYSTEM

- Radiator frontal area: 783in²
- Charge air cooler frontal area: 622in²
- Supplementary cooling fan

DRIVELINE

- Spicer I710 Series driveshaft

WHEELS & TYRES

Wheels: 8.25DC x 22.5 10-stud 335mm PCD steel

Front tyres: Dunlop SP350* 295/80R22.5

Rear: Dunlop SP431A* 11R22.5

Optional: Alcoa* 8.25DC x 22.5 Durabrite finish

- Spare wheel carrier (supplied loose)
- Alternative tyre sizes, brands and tread patterns available

*or different brand, equivalent model

CAB CONSTRUCTION

- 2180mm wide cab with zinc-coated outer panels and Electrophoretic deposited steel cab with hydraulic lift
- Four point cab mounting system with rubber block front and air springs dampers rear

CAB FEATURES

- Fully adjustable ISRI air suspension driver's seat with integrated lap sash seat belt and adjustable lumbar support
- Fixed ISRI passenger seat with lap sash seat belt
- Heavy duty trim
- Heavy duty radiator guard and stone shield
- Headlight protection grid
- Radio/CD MP3 player with Bluetooth
- Heated motorised mirrors
- 12 volt accessory socket
- Electric windows
- Electric or air horn
- Drink bottle holder
- In-cab body builder electrical and air connection
- Park brake alarm - horn alert
- Optional:** Air suspended single passenger seat (standard with Dual Control)
- Fixed passenger bench seat (Drink bottle holder not available) (Single Control only)
- LED rear tail lights
- Rotating roof light
- Sunvisor
- Variable pitch reverse buzzer
- Fire extinguisher
- Overhead console

IVECO