

APPENDIX F

Civil Engineering Report

Prepared by:

vT Consulting Engineers



153-161 Beenleigh Redland Bay Road,
Cornubia QLD 4130
Engineering Report & Stormwater
Management Plan

April 2023
Project No.: 22396
Revision No.: B



Contents

1.	Introduction	3
a.	Existing Land Use	4
2.	Erosion and Sediment Control	4
3.	Earthworks	6
4.	Roadworks	6
5.	Stormwater Drainage	7
a.	Stormwater Quality Management	8
b.	MUSIC Model	8
c.	MUSIC Model Results	10
d.	Stormwater Quantity Management	12
e.	Maintenance	15
6.	Flood Planning and Overland Flow	17
a.	Access and Carparking	17
7.	Sewer Reticulation	18
8.	Water Reticulation	19
9.	Electrical and Telecommunication	20
10.	Development Codes	20
11.	Safety in Design	20
12.	Conclusions	20
	Appendix A - Proposed Preliminary Design Drawings	21
	Appendix B - IECA Erosion Hazard Assessment Form	22
	Appendix C - IECA (Australasia) Standard Drawings	23
	Appendix D - Logan City Council Flood Report	24
	Appendix E - Logan City Council Development Codes	25
	Appendix F - SPEL Filter Operation and Maintenance Manual	26
	Appendix G - OceanProtect Filter Operation and Maintenance Manual	27



Document Status:

REVISION	PREPARED BY	REVIEWED BY	DATE
A	V. Kasturiaratchi A. Lee	A. van Tonder RPEQ 16132	13/03/2023
B	A. Lee	A. van Tonder RPEQ 16132	03/04/2023

This document is produced by vT Consulting Engineers (vTCE) for the benefit and use by the client in accordance with the terms of the agreement. vT Consulting Engineers does not and shall not assume any responsibility or liability whatsoever to any third party arising out of any use or reliance by any third party on the content of this document. Report provided in accordance with the vT Consulting Engineers terms of engagement.



1. Introduction

vT Consulting Engineers has been commissioned by Development Holdings Pty Ltd to prepare this engineering services report and stormwater management plan. The development is located at 153-161 Beenleigh Redland Bay Road, Cornubia QLD 4130. The site locality is illustrated in Figure 1.1. This report is being submitted to support the Development Approval for the proposed residential subdivision development for Logan City Council’s consideration.

The development involves construction of a proposed childcare centre with carpark and external play area.

Refer attached Appendix A for proposed layout plans and details.

The following report will detail civil engineering requirements for the development.

Street Address	153-161 Beenleigh Redland Bay Road, Cornubia QLD 4130
Real Property Description	Lot 12 SP 114352
Total Site Area	2678 m ²
Proposed Use	Material change of use – Proposed Child Care Centre
Local Authority	Logan City Council



Figure 1.1 Site Layout Plan (Google Maps)



a. Existing Land Use

The site is situated in a residential area fronting the intersection of Beenleigh Redland Bay Road and Montessa Street. Subject site is occupied by a residential dwelling and a shed situated at the middle of the block. The rest of the site is predominantly grassed with few trees and shrubs. Located near the site are residential properties, service stations, and a residential aged care facility.

The existing house and structures are to be demolished and removed.

2. Erosion and Sediment Control

Using the International Erosion Control Association's (IECA) Erosion Hazard Assessment Procedure AustIECA, 2016a), we believe the proposed development site represents an erosion risk as trigger values resulted in a total score of 18 (Refer to Appendix B for Erosion Hazard Assessment Form). IECA requires that a preliminary Erosion and Sediment Control Plan (ESCP) be submitted to the local government for approval during the planning phase if the development obtains a total point score of 17 or greater or when any trigger value is scored or exceeded.

The construction contractor is responsible for ensuring that soil and debris does not leave the site as well as the confines of the construction zone and is not deposited on external roads or existing in-use areas due to the proposed earthworks and construction activity.

Acid Sulphate Soils

The local council is listed in the Glossary (Acid Sulphate soil affected area) in State Planning Policy July 2017, indicating that this development application may require compliance with the State Planning Policy July 2017 acid sulphate soils development objectives.

Acid sulphate soil testing is typically conducted in areas with reduced levels of less than 5.0m Australian Height Datum (AHD) as stated in State Planning Policy July 2017. This policy also states that developments below 20.0m AHD that involve a Material Change of Use or operational works are required to be assessed against the State Planning Policy July 2017 acid sulphate soils development objectives. As the lowest point on this site is an approximate level of RL 7.75, we believe that there is no possibility of acid sulphate soil being present and therefore testing would be unlikely.

Figure 2.1 provides a visual aid to determining assessable development.



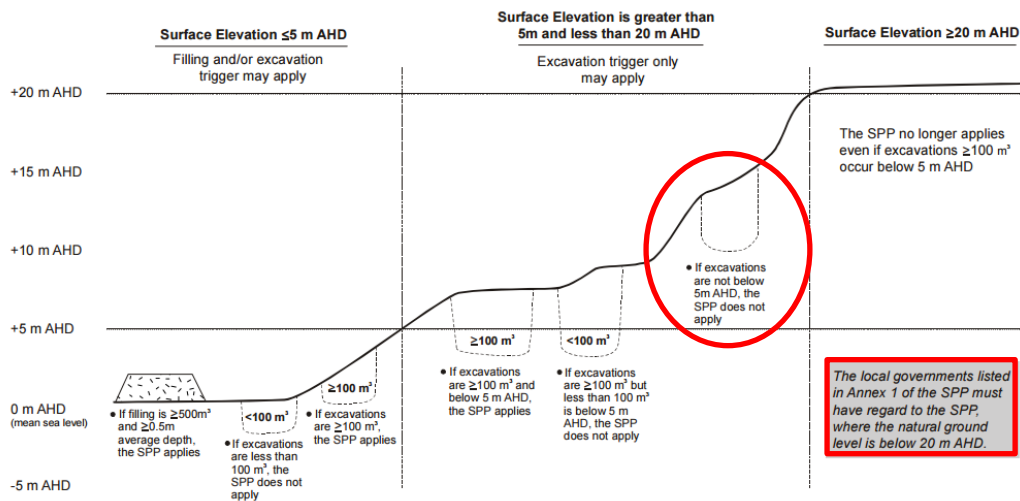

**Figure 2.1 Acid Sulphate Soils assessment diagram
(Adapted from SPP Water Quality State Interest Guideline 2016)**

As the proposed excavations are not expected to be below RL5.0m AHD, the State Planning Policy does not apply.

The requirements for Acid Sulphate Testing will be confirmed by a geotechnical engineer prior to the detailed design stage of this proposed development.

Land Disturbing Activities

Important causes/issues of erosion for this site would consist of the following:

- Precipitation and consequent run-off
- Stripping and removal of topsoil
- Removal of fill
- Other earthwork operations
- Heavy vehicle use on site
- Wind erosion

The proposed development is a short construction period which will be programmed so that the shortest period of time elapses between ground cover removal and restoration.

Erosion and Sediment Control Measures

Sediment control filter fabric will be securely placed around the downstream boundaries of the construction site. This will ensure sediment is trapped before being released into the catchment. Refer Appendix C.

An ESC measure will be provided at any vehicular access points to the site. Construction and maintenance details are given in Appendix C. A temporary construction entrance will be provided from the adjacent roads for access during construction.

A filter sock sediment trap will be utilized on all downstream stormwater inlets. Refer Appendix C for construction and maintenance details.

No clearing will be undertaken unless preceded or accompanied by installation of adequate run-off and sediment control measures, as described above.

Following practical completion of the project a minimum of 70% coverage of all soil with ground cover (i.e. topsoiling and seeding) will be provided within 30 calendar days.

During the demolition and construction phases, spraying of water will be used with care to act as a dust suppression method.

Monitoring and Maintenance Programs

Water discharge from the site will adhere to a total suspended solid content of less than 50 milligrams per litre and a pH range of between 6.5 and 8.5 at all times. If the pH of the flocculated water is not achieved, then pH adjustments will be required. This could possibly be done by a dosing of lime.

Site personnel will inspect all erosion and control measures at least at the following frequencies:

- Daily during construction works,
- Weekly when construction works are not happening,
- Within 24 hours of expected rain, and
- Within 18 hours of an impacting rainfall event.

All erosion and sediment control measures that have an order of efficiency below 75% will be corrected by the end of that working day.

3. Earthworks

For the purpose of this proposed development earthworks will be conducted for constructing the new proposed building platform. Excavation on site will be required for the service trenches. Any excess cut will need to be removed from the site by the contractor.

A geotechnical report will be prepared for the site during the detailed design stage.

4. Roadworks

The proposed development fronts on the intersection of Beenleigh Redland Bay Road and Montessa Street. New crossover will be provided along the southern boundary of site as shown on the proposed layout plans. External roadworks are not proposed for the development. No new road is to be constructed on site.



5. Stormwater Drainage

Existing site stormwater flows towards the southern direction of the subject site, along Donald Street. Existing gully pits are located in the intersection of Montessa Street and Donald Street. It is proposed for new stormwater lines to be constructed on site and flow towards a proposed detention tank. Runoff from the proposed development will also be discharged to the existing stormwater drainage as shown below in Figure 5.1.

Refer to attached Appendix A for proposed layout plans and details.

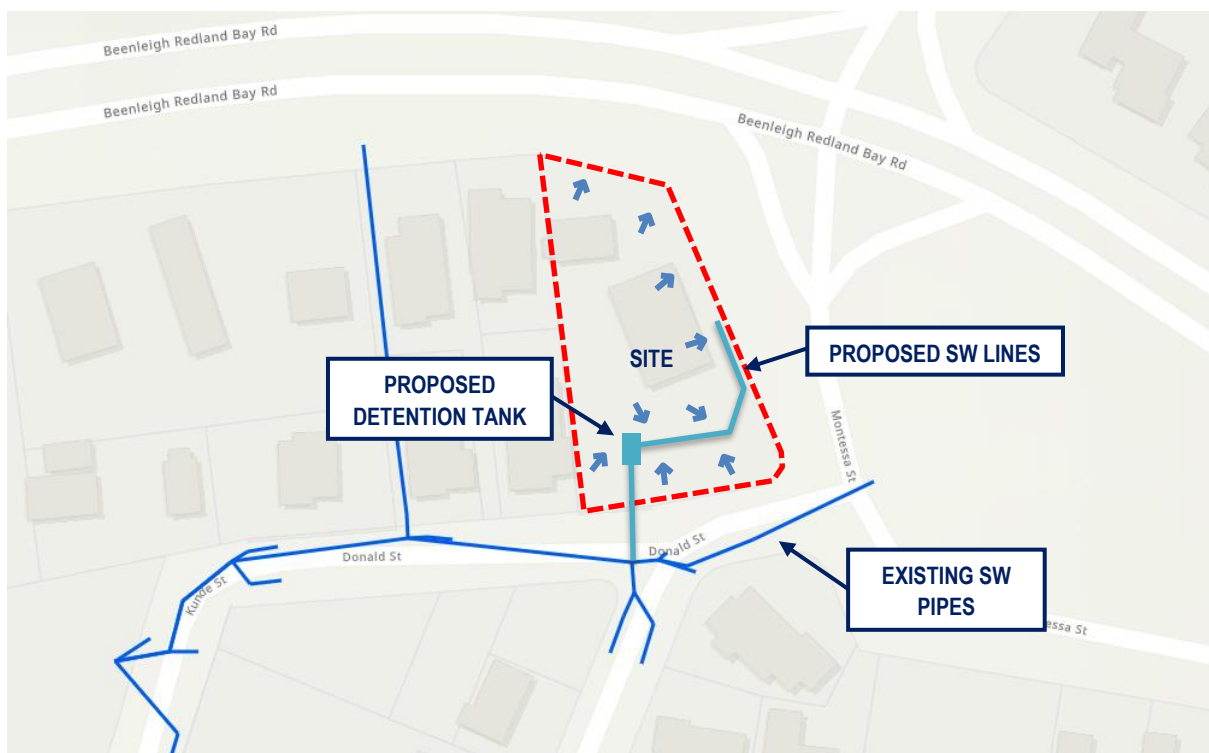

Figure 5.1 ArcGIS Stormwater Layout Map

a. Stormwater Quality Management

State Planning Policy

The State Planning Policy (SPP) applies for stormwater quality management and management of new or expanded non-tidal artificial waterways applies to development that is outlined below in Table 5.1.

SPP PART E: INTERIM DEVELOPMENT ASSESSMENT REQUIREMENTS. STATE INTEREST – WATER QUALITY	YES / NO
<i>Material change of use for urban purposes that involves a land area greater than 2500m² that:</i>	
<i>will result in an impervious area greater than 25% of the net developable area</i>	YES
<i>Will result in 6 or more dwellings</i>	NO
<i>Reconfiguring a lot for urban purposes that involves a land area greater than 2500m² and will result in six or more lots:</i>	YES
<i>Operational works for urban purposes that involve disturbing more than 2500m² of land</i>	YES

Table 5.1 Water Quality Objectives

The proposed development trigger some of the applicable items in the above Table 5.1, therefore the SPP is applicable, and compliance is expected by the local government authority.

b. MUSIC Model

The software program Model for Urban Stormwater Improvement Conceptualisation (MUSIC) Version 6 was used to assess pollutant generation and the performance of the stormwater treatment measures for the proposed development. Selection and testing of stormwater management options was undertaken in accordance with MUSIC Modelling Guidelines prepared by Water by Design (2018).

The catchment was further split to include pavement areas, road areas and landscaped areas in accordance with the MUSIC Modelling Guidelines prepared by Water by Design (2018).

Music Model Parameters

The split catchment parameters used as the MUSIC Pollutant Export Parameters are shown below in Table 5.2 and were derived from Table 3.9 of the MUSIC Modelling Guidelines prepared by Water by Design (2018).

FLOW TYPE	SURFACE TYPE	TSS LOG ¹⁰ VALUES		TP LOG ¹⁰ VALUES		TN LOG ¹⁰ VALUES	
		Mean	Std. Dev.	Mean	Std. Dev.	Mean	Std. Dev.
	Commercial						
Baseflow Parameters	Roof	N/A	N/A	N/A	N/A	N/A	N/A
	Road	0.78	0.39	-0.60	0.50	0.32	0.30
	Ground	0.78	0.39	-0.60	0.50	0.32	0.30
Stormflow Parameters	Roof	1.30	0.38	-0.89	0.34	0.37	0.34
	Road	2.43	0.38	-0.30	0.34	0.37	0.34
	Ground	2.16	0.38	-0.39	0.34	0.37	0.34

Table 5.2 Source Node MUSIC Pollutant Export Parameters

The parameters used as the MUSIC Rainfall-Runoff Parameters are shown in the table below, and were derived from Appendix A, Table A1.2 of the MUSIC Modelling Guidelines prepared by Water by Design (2018).

PARAMETER	COMMERCIAL
Rainfall Threshold (mm)	1
Soil Storage Capacity (mm)	18
Initial Storage (% Capacity)	10
Field Capacity (mm)	80
Infiltration Capacity Coefficient - a	243
Infiltration Capacity Exponent - b	0.6
Initial Depth (mm)	50
Daily Recharge Rate (%)	0
Daily Baseflow Rate (%)	31
Daily Deep Seepage Rate (%)	0

Table 5.3: MUSIC Rainfall-Runoff Parameters

Music Model Treatment Parameters

Two approved stormwater treatment options are provided below. All proposed products are to be installed, operated, and maintained in accordance with the manufacture's specifications.

An alternative proprietary system may be proposed during the detailed design of the project, subject to certification by the manufacturer and a Registered Professional Engineer of Queensland (RPEQ) that the alternative system meets the Logan City Council and SPP requirements.

Treatment Option 1 – SPEL

The proprietary system is designed to treat the stormwater runoff by filtering the runoff through 4No. SPEL Stormsack and 3No. SPEL filter cartridges (SPELFilter system) in accordance with the manufacturers specifications. The MUSIC model parameters for Treatment Option 1 have been provided by SPEL.

Refer to Appendix F for SPEL Filter Operation and Maintenance Manual.

Treatment Option 2 – OceanProtect

The proprietary system is designed to treat the stormwater runoff by filtering the runoff through 4No. grated pits (OceanGuards) and 5No. cartridge system (Tall(690) Psorb StormFilter) in accordance with the manufacturers specifications. The MUSIC model parameters for Treatment Option 2 have been provided by OceanProtect.

Refer to Appendix G for OceanProtect Filter Operation and Maintenance Manual.

c. MUSIC Model Results

Using the MUSIC software, the treatment train for the catchment areas was designed to comply with the water quality objectives (WQO). It was determined that the water quality objectives for the whole proposed development were met as shown in the table below:

POLLUTANT TYPES	WQO OBJECTIVES REDUCTION (%)
Total Suspended Solids (kg/yr)	80.0
Total Phosphorus (kg/yr)	60.0
Total Nitrogen (kg/yr)	45.0
Litter/gross pollutants (kg/yr)	90.0

Table 5.5 Water Quality Treatment Results

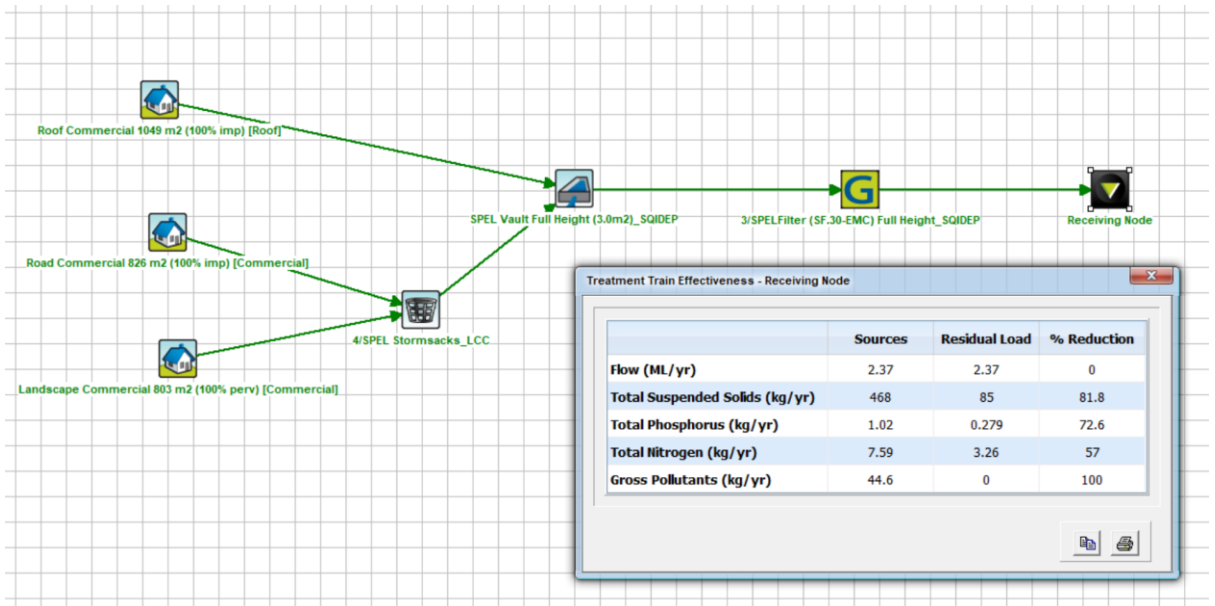

Treatment Option 1 – SPEL

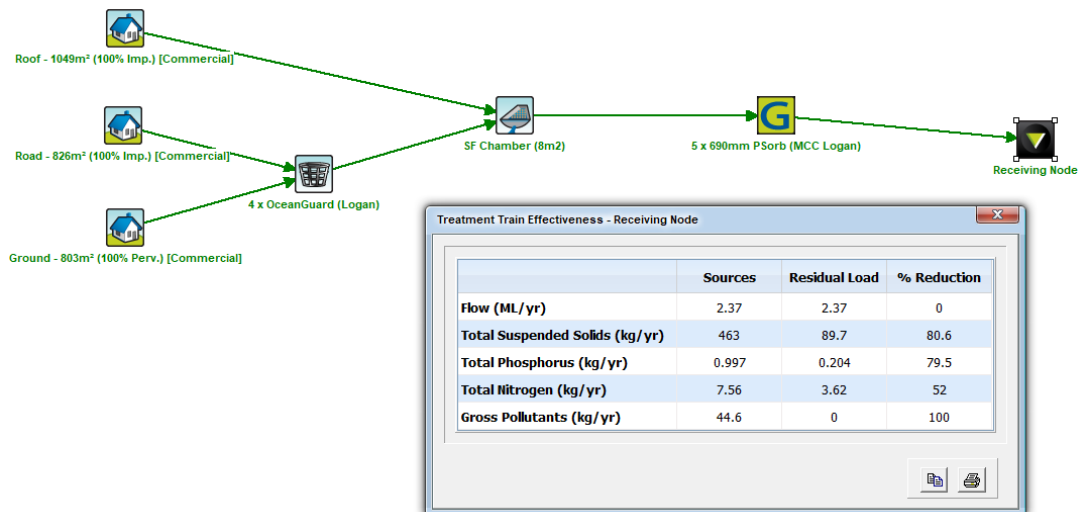

Treatment Option 2 – OceanProtect

As shown by the above results, the proposed stormwater treatment train adopts best practice stormwater treatment and will achieve the required Water Quality Objectives. The proposed design is in accordance with the Water Sensitive Urban Design Technical Design Guidelines (by Water by Design).



d. Stormwater Quantity Management

Detailed calculations of the flow from the site are summarised in the table below:

PARAMETERS			
Catchment Area - Developed:	2678	m ²	
Catchment Area - Undeveloped:	2678	m ²	
Runoff Coefficient (C ₁₀) - Developed:	0.83	t _c = 7	min.
Runoff Coefficient (C ₁₀) - Undeveloped:	0.71	t _c = 7	min.

ARI		2yr	5yr	10yr	20yr	50yr	100yr
Rainfall Intensity	mm/hr	115	157	186	213	249	276
Frequency Factor	f _y =	0.85	0.95	1.00	1.05	1.15	1.20
Developed C	C _u =	0.71	0.79	0.83	0.87	0.95	1.00
Undeveloped C	C _d =	0.60	0.67	0.71	0.75	0.82	0.85

FLOWS									
Developed Flow	Q _u =	C*I*A	l/s	60.7	92.3	114.8	137.9	176.0	205.3
Undeveloped Flow	Q _d =Q _i =	C*I*A	l/s	51.3	78.2	98.2	118.8	151.9	174.5
Difference	Q _o =		l/s	-9.4	-14.1	-16.6	-19.1	-24.1	-30.8

Table 5.6 Quantity Summary using Rational Method

The proposed development will have a larger impervious area than the existing site and will require a stormwater detention system to mitigate the effects of the additional runoff.

The stormwater runoff from the development site will discharge into the proposed detention basin to ensure no actionable nuisance is caused to surrounding properties.

XP Storm is a software package for dynamic modelling of urban stormwater systems, river systems and floodplains. XP Storm was used to determine the required detention storage volume to ensure that the developed flow is equal to or less than the pre-development flow. The Laurensen method was used for determining the volume of runoff within the XP Storm model. Figure 5.4 shows the pre-development stormwater flows for various storm events. For clarity, only the maximum storm events for each return period are shown.

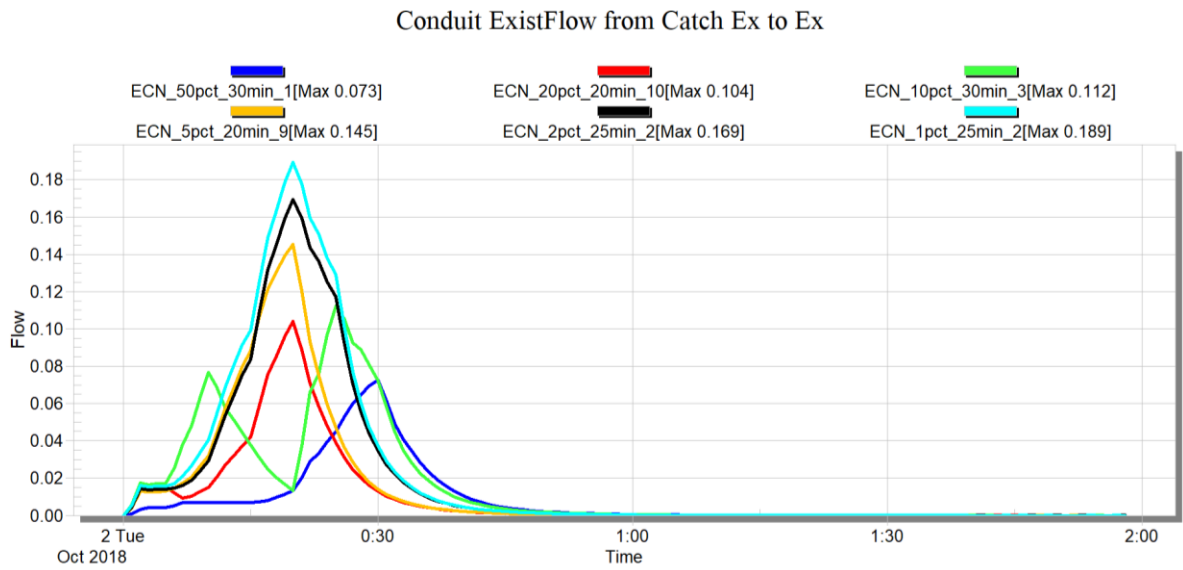

Figure 5.4 Existing stormwater flows for various storm events

As a check for the XP Storm model, the Rational Method was used as outlined in Section 4.3 of the Queensland Urban Drainage Manual (QUDM 2017), to determine the peak flow rate corresponding to the minor and major storm events for the existing conditions. It should be noted that the Rational Method was not used in the calculation of detention volumes but rather as a check that the peak flow outputs for the existing scenario in the XP Storm model were feasible.

Comparing the results from Figure 5.4 and the undeveloped flows within Table 5.6, the relationship is good between the XP Storm and Rational method results and therefore the XP Storm model output is acceptable.

Settings within the XP Storm models are shown in Tables 5.7. Results summaries are shown in Tables 5.8.

PARAMETER	DETENTION TANK
Detention Volume (m ³)	6.32
Base Area (m ²)	6.25
Minor Orifice Area (m ²)	0.0491 (0.25m dia)
Major Orifice IL Above Minor Orifice IL (m)	0.30
Major Orifice Area (m ²)	0.0661 (0.29m dia)

Table 5.7 Detention Parameters

EVENT	PRE-DEVELOPMENT (l/s)	POST-DEVELOPMENT (l/s)
2yr	73	61
5yr	104	81
10yr	112	92
20yr	145	125
50yr	169	142
100yr	189	158

Table 5.8 Pre- and Post-Development outlet flows



The detention basin was sized using the XP Storm model, the results of which are shown below in Figure 5.5.

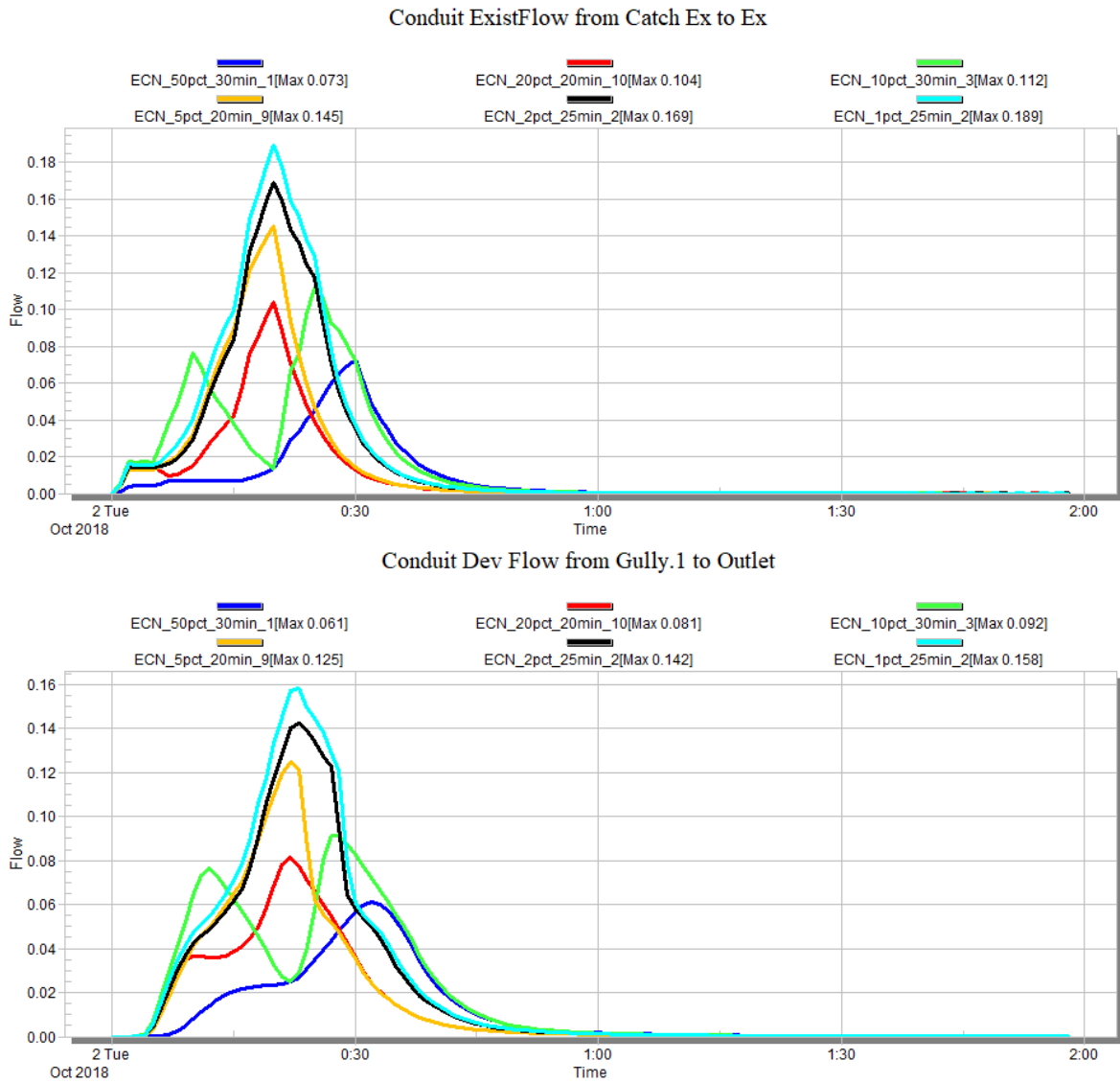

Figure 5.5 Undeveloped vs. Developed stormwater flows for various storm events

Figure 5.5 shows comparisons of the 2yr, 5yr, 10yr, 20yr, 50yr and 100yr flow events for pre- and post-development scenarios using a detention basin volume of **6.32m³** plus freeboard.



e. Maintenance

Construction Phase Management Plan

Potential construction phase impacts include the following:

- Sedimentation and erosion
- Management of contaminated soils and materials on the site Construction Material (such as cement)

General

The objective of the Construction Phase Management Plan is to comply with the requirements of the Queensland Environmental Protection Act 1994 and Environmental Protection (Water) Policy 2009 so that the environmental values of effected receiving waters are maintained or enhanced. In essence the purpose of the Plan is to prevent polluted stormwater being discharged to the local waterways.

Performance Indicators

The management is not being effective when any of the following occur during the construction phase of the project.

- The required water quality objectives are not achieved,
- Contaminated water is released off site.

Construction Phase Management of Sedimentation and Erosion

Existing vegetation from site will be removed in stages as required to reduce the likelihood of surface erosion. A sediment and siltation fence will be erected around the property boundary to ensure that sediment is not washed off site and onto adjacent properties or roads. Entry and exit from the site will be restricted to a single stabilised location to minimise the rise of onsite transport of silt sediment or mud. It is anticipated that a layer of crushed rock will provide the necessary stabilisation of the access route. If required a specific bunded wash down area will be provided for the cleaning of plant before leaving the site and all wash down wastewater will be collected. In the event that debris or sediment leaves the site it will be cleaned.

Management of Imported Materials

Any material imported to the site including construction materials will be stockpiled in a location where it cannot contaminate the stormwater system or stormwater runoff.

Complaint Response

The contractor will erect signage at the entrance to the works with contact information, including afterhours contact numbers. The contractor will properly deal with all complaints.

Monitoring and Reporting

All sediment and erosion control devices will be checked daily and after rainfall events by the construction site supervisor. Defective or full devices will be cleaned and repaired as required. Regular inspections and maintenance of the storm water system will be carried out by the property owner. The civil components (structural and erosion) are to be assessed by a suitably qualified engineer as required.



Stormwater Treatment Systems

The design, installation and ongoing maintenance of the stormwater treatment systems is to be in accordance with the manufacturers specifications and in accordance with the service station operator maintenance guidelines and procedures.

It remains the service provider and user's responsibility to maintain the treatment and site in accordance with the current State Planning Policy and legislation requirements.

Lifecycle cost assessment

There will be no abnormal capital or recurrent costs for the proposed stormwater strategy.



6. Flood Planning and Overland Flow

Figure 6.1 below shows the extent of flooding in relation to the site. As shown, the subject site is not located on the Flood hazard overlay map in the Logan Planning Scheme 2015. In addition, site is not impacted by river, creek or waterway and overland flow sources. The project development site is not located within an overland flow area, and it is anticipated that development complies with Logan City Council's flooding requirements.

vT Consulting Engineers have not been commissioned to complete a flood assessment report for this development.

Please refer to Appendix D for a copy of the Logan City Council's Flood Report for 153-161 Beenleigh Redland Bay Road, Cornubia QLD 4130.

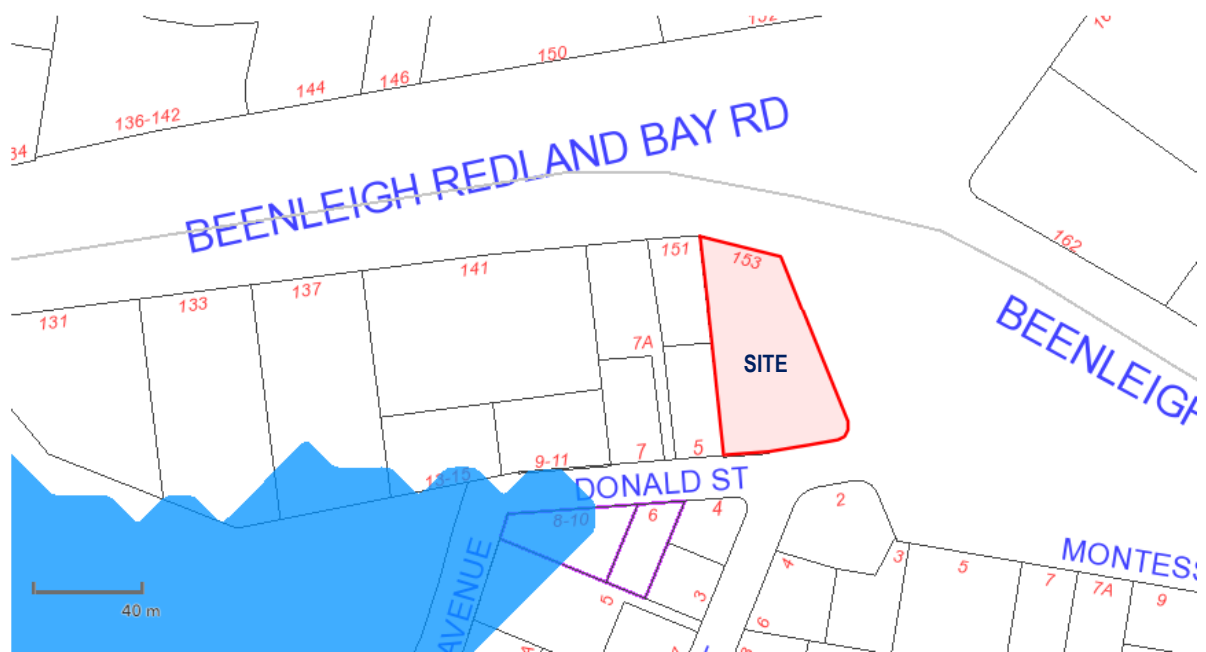

Figure 6.1 Logan City Council Flood Hazard Mapping

a. Access and Carparking

The development's carparking floor level is proposed well above the minimum non-habitable floor level. The catchment flows within the kerb and channel/road fall well above the depth*velocity threshold line in the road capacity table. Therefore, the proposed development will provide safe vehicular and pedestrian access during all rainfall events up to and including Q100.

7. Sewer Reticulation

The existing site has a sewer property connection that connects to a non-pressure sewer pipeline (asset ID 13370) located at the southern boundary of the site along Donald Street as shown below in Figure 7.1 ArcGIS Sewer infrastructure plan. This sewer property connection is proposed to be upgraded and reused to service the proposed development.

For more details refer to the engineering plans in Appendix A.

Internal house drainage design for this proposed development will be by others.

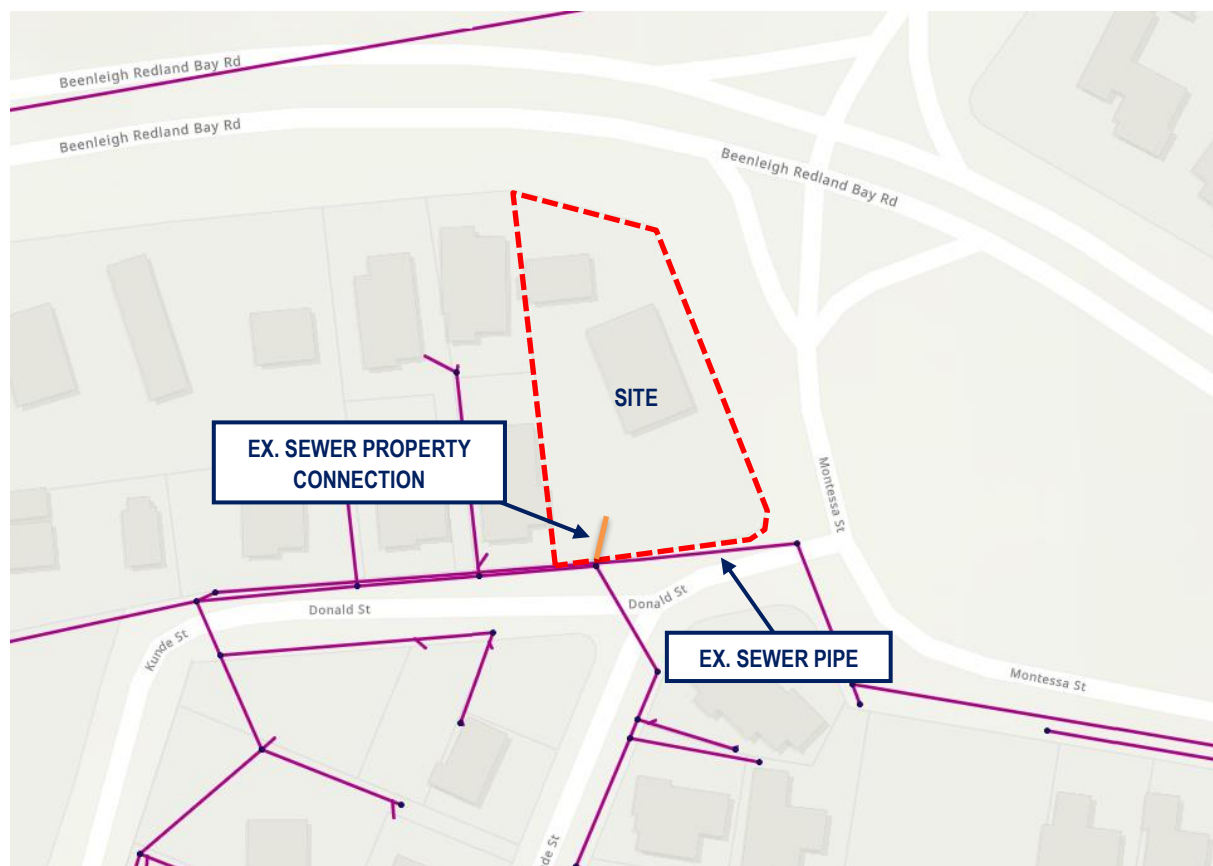

Figure 7.1 ArcGIS sewer infrastructure plan

8. Water Reticulation

The existing water main runs along the frontage of the site, along Beenleigh Redland Bay Road and Montessa Street. It is proposed for the childcare centre development to upgrade and reuse the existing water connection provided to the site from the water main running along Montessa Street as shown below in Figure 8.1 ArcGIS water reticulation plan.

As the nearest existing fire hydrant is about 4.52m away from the site, no new fire hydrant is to be installed. For more details refer to the engineering plans in Appendix A.

The internal water supply design for this proposed development will be by others.

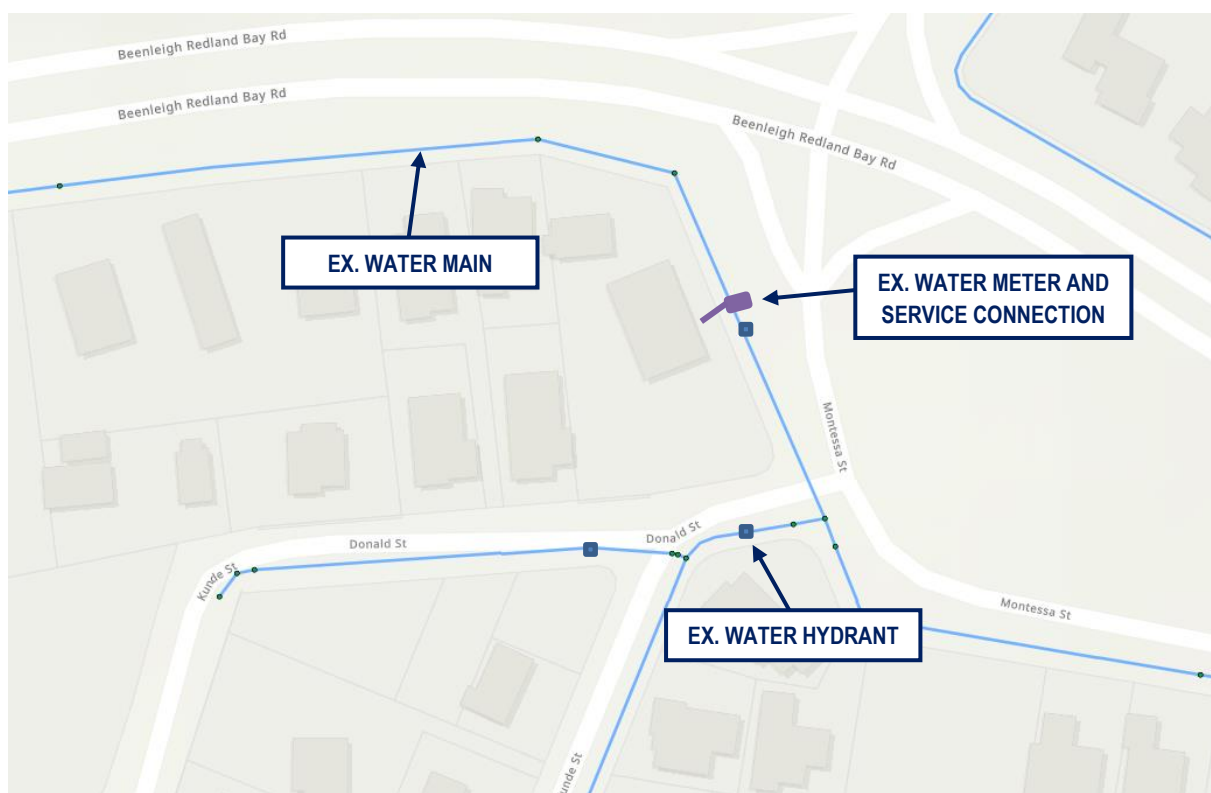

Figure 8.1 ArcGIS water reticulation plan

9. Electrical and Telecommunication

The electrical supply and communications supply for this proposed development will be by others.

10. Development Codes

The following applicable Local Codes have been completed to address the proposed development and are included in Appendix E:

- Logan City Council Infrastructure Code
- Logan City Council Filling and Excavation Code

11. Safety in Design

At the time of preparing this report, it is considered that there is no atypical safety in design issues for a project of this type and use. Typical issues to be reviewed include but are not limited to construction activities, falls, confined spaces, excavations, and hazardous materials.

A full review of and preparation of a Safety In Design report will be conducted during the detailed design of the project by the project design engineer. The ongoing implementation, review and amendments to the Safety in Design register is to be by the property owner or users.

12. Conclusions

vT Consulting Engineers has undertaken a preliminary review of civil engineering services required for the proposed development located at 153-161 Beenleigh Redland Bay Road, Cornubia QLD 4130.

Based on all the findings outlined in this report, vT Consulting Engineers believes that, should the recommendation contained within the report be implemented, there are no significant engineering issues in relation to this development.



Appendix A - Proposed Preliminary Design Drawings



LEGEND	
	EXISTING PROPERTY BOUNDARY
	EXISTING EASEMENT BOUNDARY
	EXISTING CONTOUR - MAJOR
	EXISTING CONTOUR - MINOR
	EXISTING BUILDING
	EXISTING KERB AND CHANNEL
	EXISTING KERB
	EXISTING RETAINING WALL
	EXISTING STORMWATER DRAINAGE
	EXISTING ROOFWATER DRAINAGE
	EXISTING SEWER
	EXISTING WATER
	EXISTING ELECTRICAL
	EXISTING ELEC. OVERHEAD
	EXISTING COMMUNICATIONS
	ABANDON EXISTING SERVICE
	PROPERTY BOUNDARY
	EASEMENT BOUNDARY
	CONTOUR - MAJOR
	CONTOUR - MINOR
	BUILDING
	EARTHWORKS TOP OF BATTER
	EARTHWORKS BOTTOM OF BATTER
	RETAINING WALL
	SEDIMENT FENCE
	FENCE - TYPE 1
	KERB AND CHANNEL
	KERB
	STORMWATER DRAINAGE
	ROOFWATER DRAINAGE
	SUBSOIL DRAIN
	STORMWATER TABLE DRAIN
	SEWER
	WATER
	EXISTING SURFACE LEVEL (ESL)
	FINISHED SURFACE LEVEL (FSL)
	BULK EARTHWORKS LEVEL (BEL)

- CONTRACTOR TO ENSURE SURROUNDING ROADS ARE KEPT CLEAN AND FREE OF DEBRIS DURING CONSTRUCTION. TYPICAL.
- CONTRACTOR TO PROVIDE TRAFFIC CONTROL (AS REQUIRED) AND ENSURE WORK ZONES ARE SAFE DURING CONSTRUCTION. TYPICAL.
- PROVIDE KERB INLET SEDIMENT PROTECTION AT ALL DOWNSTREAM GULLIES UPTO 50m FROM SITE. TYPICAL.
- SITE TO BE CLEARED IN PREPARATION FOR BUILDING CONSTRUCTION. ALL EXISTING STRUCTURES (INCLUDING ANY PILES) AND SITE IMPROVEMENTS TO BE DEMOLISHED AND REMOVED, UNLESS NOTED OTHERWISE.



LAYOUT PLAN
SCALE 1:200

PLOTTED: 20.03.2023

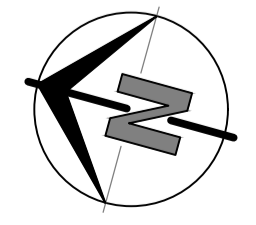

REV.	DATE	AMENDMENT	BY	APP.
B	20.03.23	GENERAL AMENDMENTS	AL	AvT
A	08.02.23	ISSUE FOR APPROVAL	JT	AvT

VT CONSULTING ENGINEERS
 A: PO Box 26, Carina QLD 4152
 E: admin@vtce.com.au
 Ph: 1300 185 737
 W: vtce.com.au

CLIENT: **ACCORD**

SCALE: AS SHOWN	DRAWN: JT
SHEET SIZE: A1	DESIGN: ZL
DATUM: AHD	CHECKED: ZL
APPROVED:	

PROJECT: PROPOSED CHILDCARE DEVELOPMENT
 153 BEENLEIGH REDLAND BAY ROAD, CORNUBIA

DRAWING TITLE: PRELIMINARY EROSION AND SEDIMENT CONTROL LAYOUT PLAN

JOB No:	22396
DRAWING No:	P100
REV:	B

CONSTRUCTION ENTRY/ EXIT NOTES

1. STRIP THE TOPSOIL LEVEL THE SITE AND COMPACT THE SUBGRADE.
2. COVER THE AREA WITH NEEDLE-PUNCHED GEOTEXTILE.
3. CONSTRUCT A 200mm THICK PAD OVER THE GEOTEXTILE USING ROAD BASE OR 30mm AGGREGATE.
4. ENSURE THE STRUCTURE IS AT LEAST 15m LONG OR TO BUILDING ALIGNMENT AND AT LEAST 3m WIDE.
5. WHERE A SEDIMENT FENCE JOINS ONTO THE STABILISED ACCESS, CONSTRUCT A HUMP IN THE STABILISED ACCESS TO DIVERT WATER TO THE SEDIMENT FENCE.

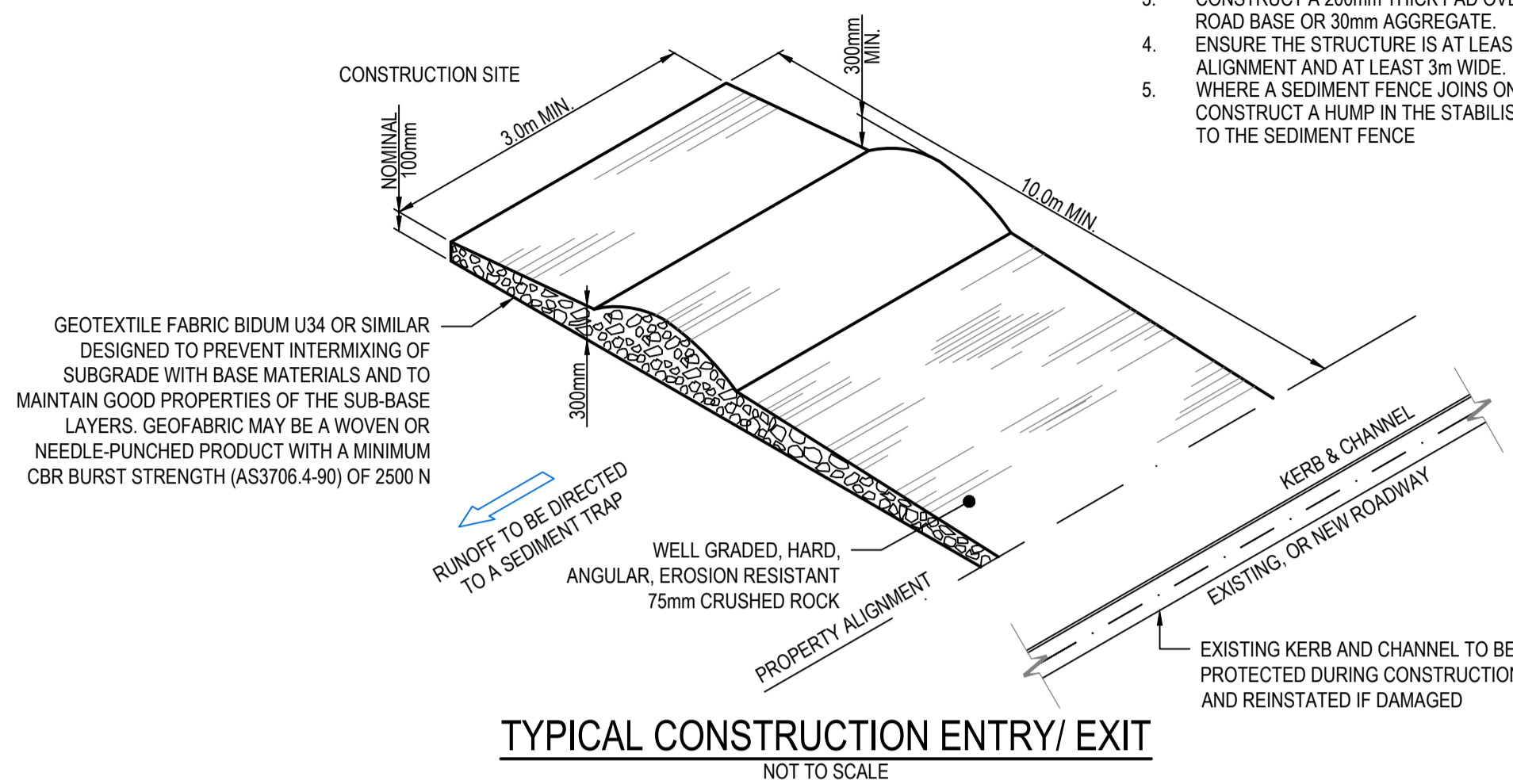

TYPICAL CONSTRUCTION ENTRY/ EXIT
NOT TO SCALE

INLET SEDIMENT TRAP NOTES

1. INSTALL FILTERS TO KERB INLETS ONLY AT SAG POINTS.
2. FABRICATE A SLEEVE MADE FROM GEOTEXTILE OR WIRE MESH LONGER THAN THE LENGTH OF THE INLET PIT AND FILL IT WITH 25mm TO 50mm GRAVEL.
3. FORM AN ELLIPTICAL CROSS-SECTION ABOUT 150mm HIGH x 400mm WIDE.
4. PLACE THE FILTER AT THE OPENING LEAVING AT LEAST A 100mm SPACE BETWEEN IT AND THE KERB INLET. MAINTAIN THE OPENING WITH SPACER BLOCKS.
5. FORM A SEAL WITH THE KERB TO PREVENT SEDIMENT BYPASSING THE FILTER.
6. SANDBAGS FILLED WITH GRAVEL CAN SUBSTITUTE FOR THE MESH OR GEOTEXTILE PROVIDING THEY ARE PLACED SO THAT THEY FIRMLY ABUT EACH OTHER AND SEDIMENT-LADEN WATERS CANNOT PASS BETWEEN.

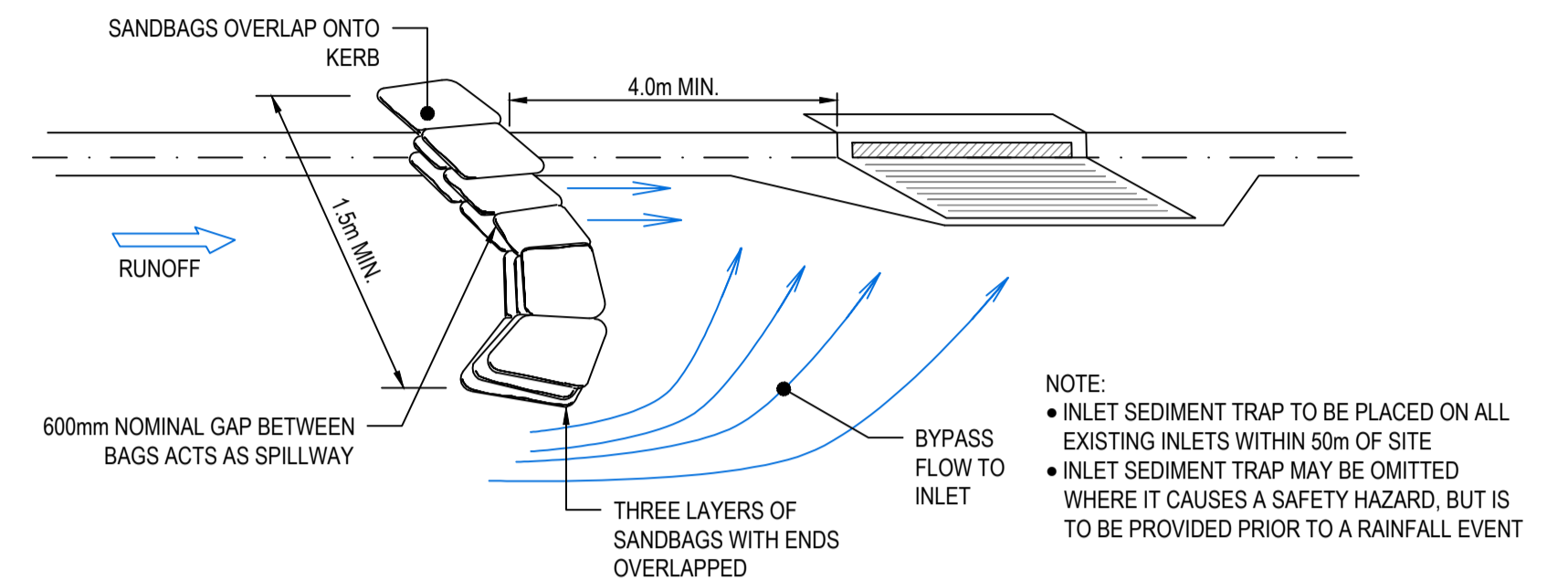

TYPICAL ON GRADE KERB INLET SEDIMENT TRAP
NOT TO SCALE

STOCKPILE NOTES

1. PLACE STOCKPILES MORE THAN 2 (PREFERABLY 5) METRES FROM EXISTING VEGETATION, CONCENTRATED WATER FLOW, ROADS AND HAZARD AREAS.
2. CONSTRUCT ON THE CONTOUR AS LOW, FLAT, ELONGATED MOUNDS.
3. WHERE THERE IS SUFFICIENT AREA, TOPSOIL STOCKPILES SHALL BE LESS THAN 2 METRES IN HEIGHT.
4. WHERE THEY ARE TO BE IN PLACE FOR MORE THAN 10 DAYS, STABILISE FOLLOWING THE APPROVED ESCP OR SWMP TO REDUCE THE C-FACTOR TO LESS THAN 0.10.
5. CONSTRUCT EARTH BANKS ON THE UPSLOPE SIDE TO DIVERT WATER AROUND STOCKPILES AND SEDIMENT FENCES 1 TO 2 METRES DOWNSLOPE.

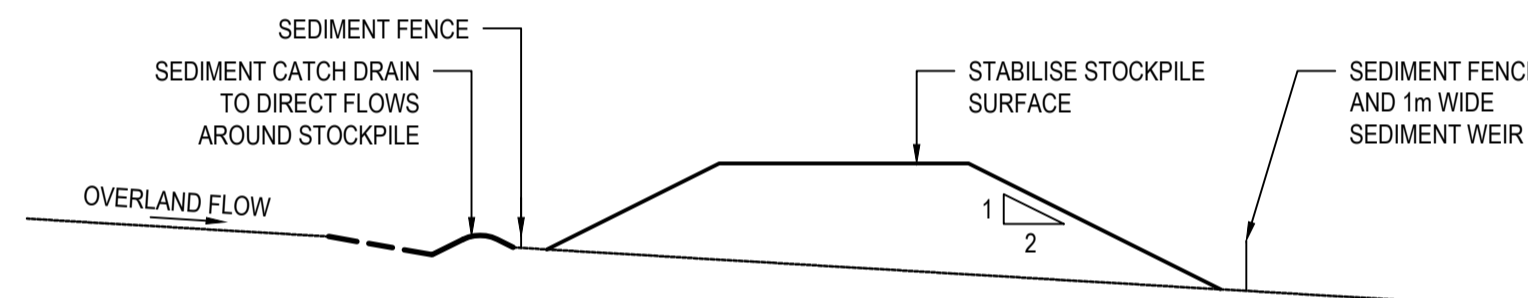

TYPICAL STOCKPILE
NOT TO SCALE

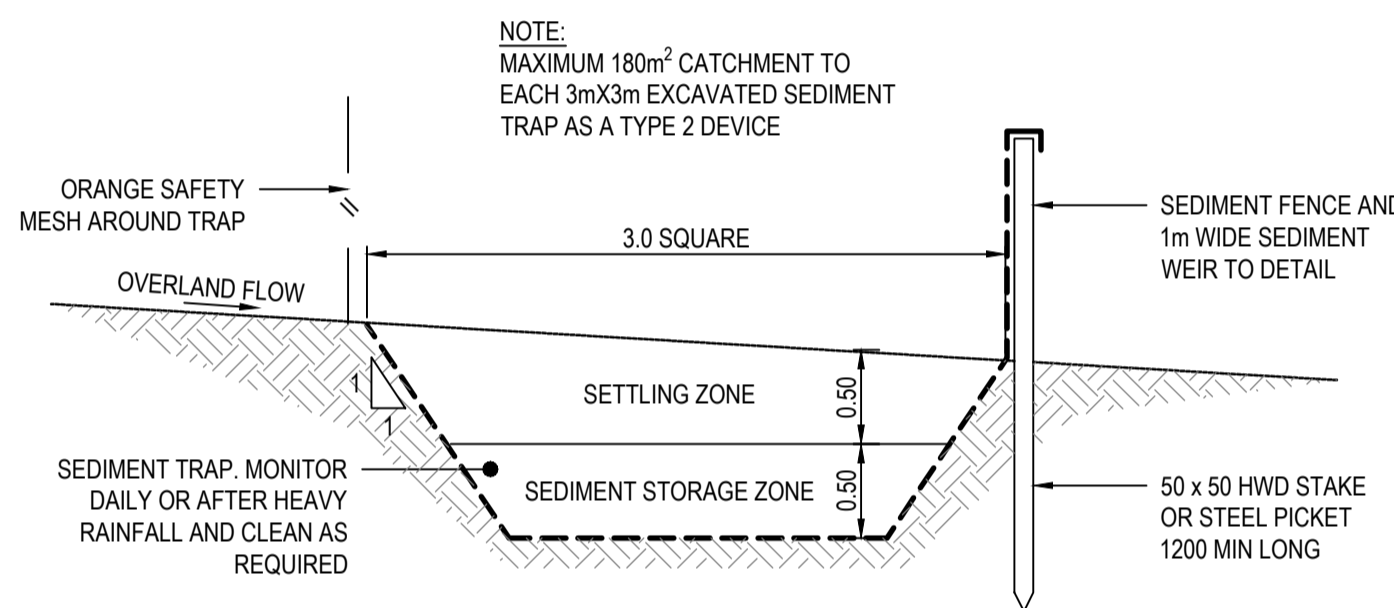

TYPICAL EXCAVATED SEDIMENT TRAP SECTION
NOT TO SCALE

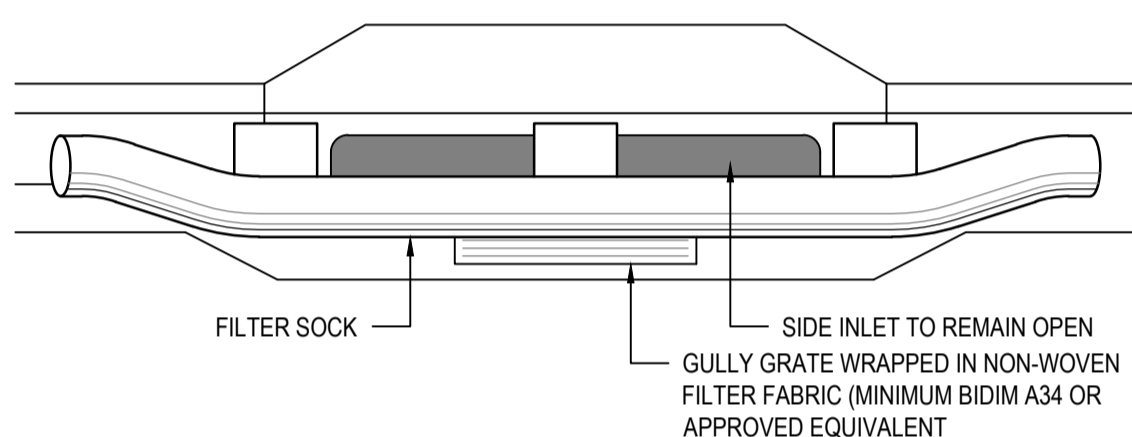

TYPICAL SAG KERB INLET SEDIMENT TRAP
NOT TO SCALE

SEDIMENT FENCE NOTES

1. CONSTRUCT SEDIMENT FENCES AS CLOSE AS POSSIBLE TO BEING PARALLEL TO THE CONTOURS OF THE SITE, BUT WITH SMALL RETURNS AS SHOWN IN THE DRAWING TO LIMIT THE CATCHMENT AREA OF ANY ONE SECTION. THE CATCHMENT AREA SHOULD BE SMALL ENOUGH TO LIMIT WATER FLOW IF CONCENTRATED AT ONE POINT TO 50L/s IN THE DESIGN STORM EVENT, USUALLY THE 10-YEAR EVENT.
2. CUT A 150mm DEEP TRENCH ALONG THE UPSLOPE LINE OF THE FENCE FOR THE BOTTOM OF THE FABRIC TO BE ENTRENCHED.
3. DRIVE 1.5m LONG STAR PICKETS INTO GROUND AT INTERVALS EDGE OF THE TRENCH. ENSURE ANY STAR PICKETS ARE FITTED WITH SAFETY CAPS.
4. FIX SELF-SUPPORTING GEOTEXTILE TO THE UPSLOPE SIDE OF THE POSTS ENSURING IT GOES TO THE BASE OF THE TRENCH. FIX THE GEOTEXTILE WITH WIRE TIES OR AS RECOMMENDED BY THE MANUFACTURER. ONLY USE GEOTEXTILE SPECIFICALLY PRODUCED FOR SEDIMENT FENCING. THE USE OF SHADE CLOTH FOR THIS PURPOSE IS NOT SATISFACTORY.
5. JOIN SECTIONS OF FABRIC AT A SUPPORT POST WITH A 150mm OVERLAP. BACKFILL THE TRENCH OVER THE BASE OF THE FABRIC AND COMPACT IT THOROUGHLY OVER THE GEOTEXTILE.

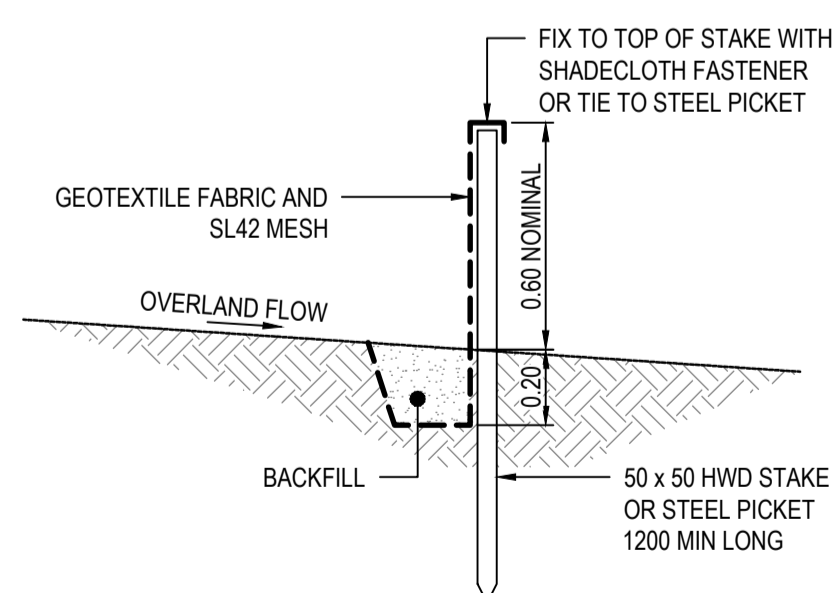

TYPICAL SEDIMENT FENCE SECTION
NOT TO SCALE

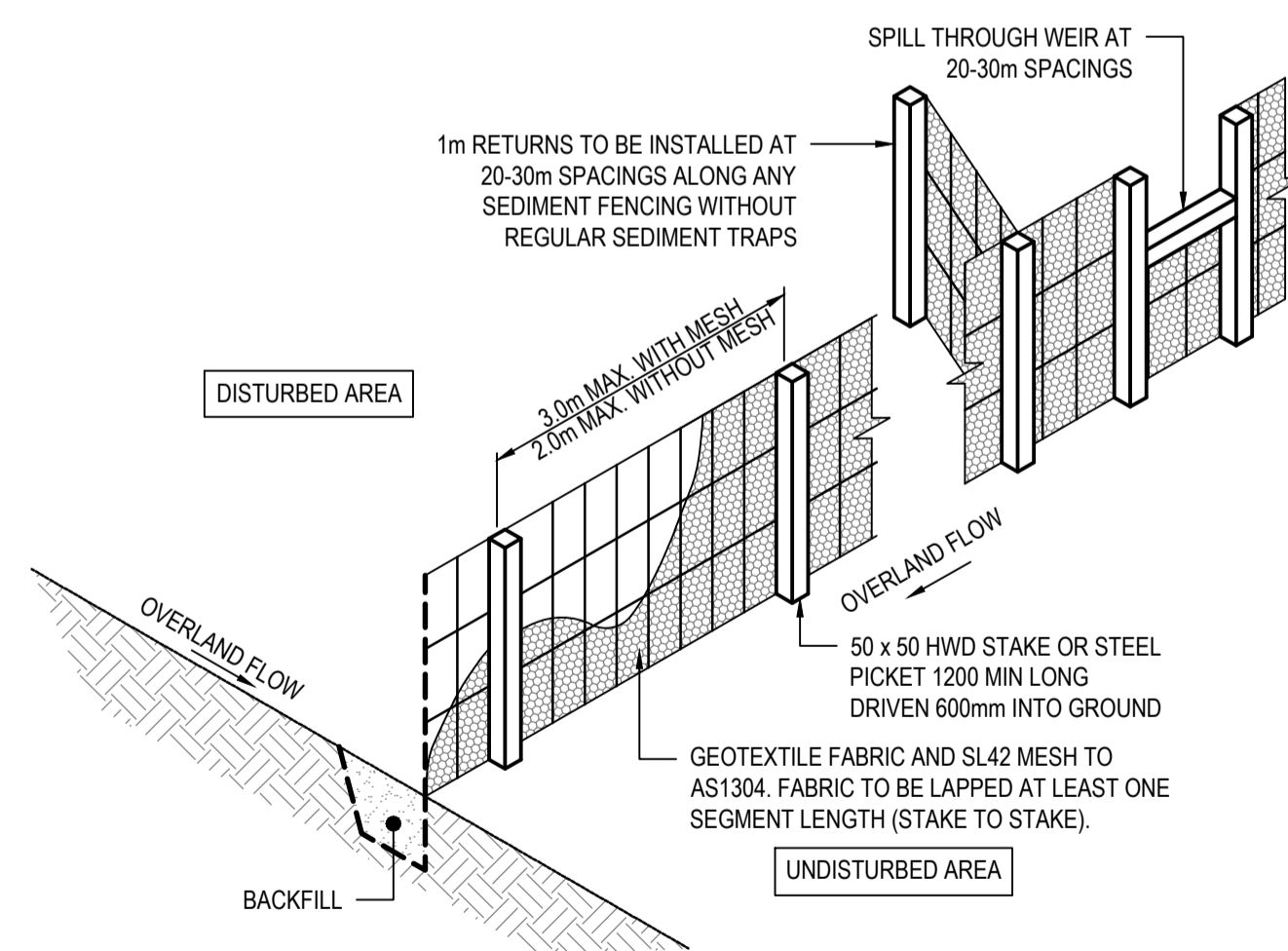

TYPICAL SEDIMENT FENCE ELEVATION
NOT TO SCALE

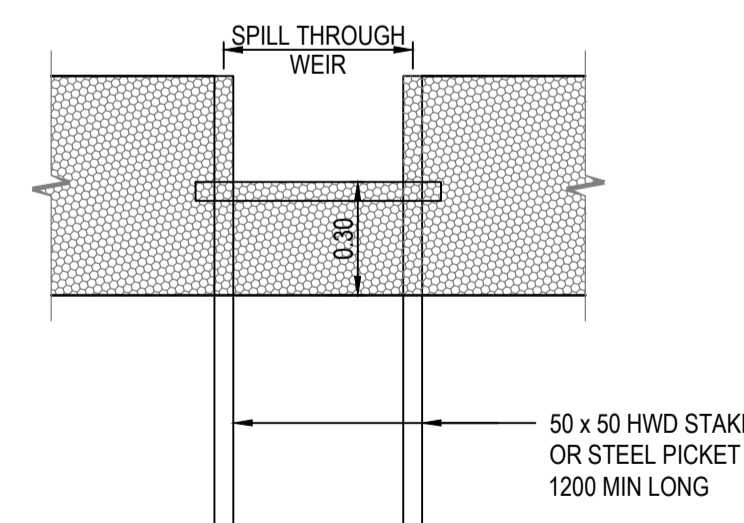

TYPICAL SEDIMENT WEIR ELEVATION
NOT TO SCALE

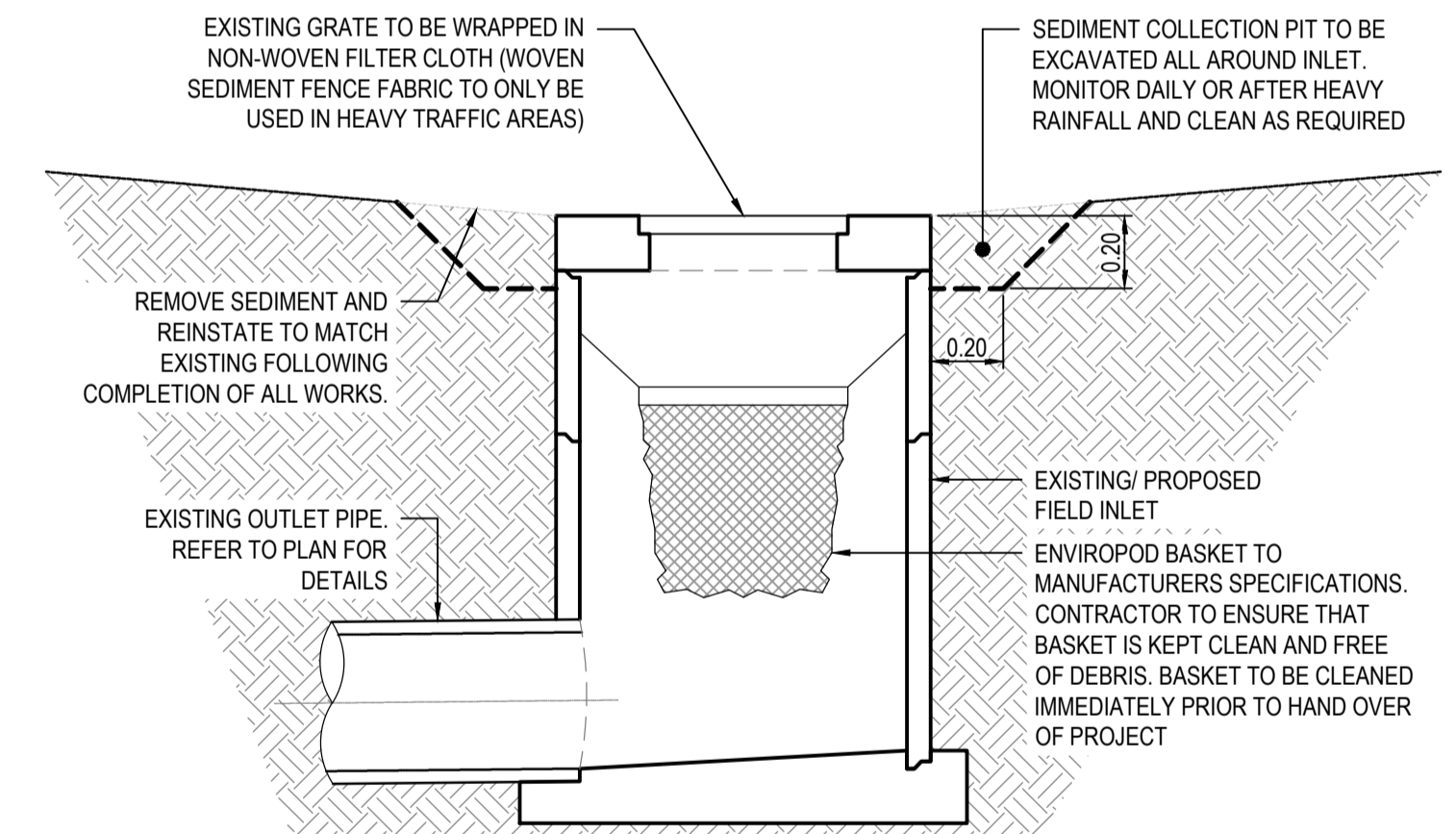

TYPICAL FIELD INLET SEDIMENT TRAP
NOT TO SCALE

PLOTTED: 20.03.2023

REV.	DATE	AMENDMENT	BY:	APP:
B	20.03.23	GENERAL AMENDMENTS	AL	AvT
A	08.02.23	ISSUE FOR APPROVAL	JT	AvT

VT CONSULTING ENGINEERS
 PO Box 26, Carina QLD 4152
 E: admin@vtce.com.au
 Ph: 1300 185 737
 W: vtce.com.au

CLIENT: **ACCORD**

SCALE: AS SHOWN	DRAWN: JT
SHEET SIZE: A1	DESIGN: ZL
DATUM: AHD	CHECKED: ZL
APPROVED:	

PROJECT: **PROPOSED CHILDCARE DEVELOPMENT**
 153 BEENLEIGH REDLAND BAY ROAD, CORNUBIA

DRAWING TITLE: **PRELIMINARY EROSION AND SEDIMENT CONTROL DETAILS**

JOB No:	22396
DRAWING No:	P110
REV:	B

LEGEND	
	EXISTING PROPERTY BOUNDARY
	EXISTING EASEMENT BOUNDARY
	EXISTING CONTOUR - MAJOR
	EXISTING CONTOUR - MINOR
	EXISTING BUILDING
	EXISTING KERB AND CHANNEL
	EXISTING KERB
	EXISTING RETAINING WALL
	EXISTING STORMWATER DRAINAGE
	EXISTING ROOFWATER DRAINAGE
	EXISTING SEWER
	EXISTING WATER
	EXISTING ELECTRICAL
	EXISTING ELEC. OVERHEAD
	EXISTING COMMUNICATIONS
	ABANDON EXISTING SERVICE
	PROPERTY BOUNDARY
	EASEMENT BOUNDARY
	CONTOUR - MAJOR
	CONTOUR - MINOR
	BUILDING
	EARTHWORKS TOP OF BATTER
	EARTHWORKS BOTTOM OF BATTER
	RETAINING WALL
	SEDIMENT FENCE
	FENCE - TYPE 1
	KERB AND CHANNEL
	KERB
	STORMWATER DRAINAGE
	ROOFWATER DRAINAGE
	SUBSOIL DRAIN
	STORMWATER TABLE DRAIN
	SEWER
	WATER
	EXISTING SURFACE LEVEL (ESL)
	FINISHED SURFACE LEVEL (FSL)
	BULK EARTHWORKS LEVEL (BEL)

EARTHWORKS VOLUMES	
AN ALLOWANCE OF 100mm HAS BEEN MADE FOR STRIPPING OF TOPSOIL AND LATENTS. STRIP DEPTH TO BE CONFIRMED ON SITE. TRIMMING TOLERANCE +0mm/-20mm.	
APPROXIMATE INSITU EARTHWORKS VOLUMES FROM STRIPPED SURFACE LEVEL TO BULK EARTHWORKS LEVEL HAVE BEEN CALCULATED AS:	
	CUT: 955m³
	FILL: 642m³
VOLUMES PROVIDED ARE INDICATIVE ONLY AND THE CONTRACTOR IS RESPONSIBLE FOR VERIFYING THE VOLUMES PRIOR TO TENDERING AND CONSTRUCTION. REFER TO STRUCTURAL ENGINEERS DETAILS FOR SAFE BEARING CAPACITY REQUIREMENTS. NO ALLOWANCE HAS BEEN MADE FOR EXCAVATION OF STRUCTURAL FOOTING, SERVICE TRENCHES OR PITS.	

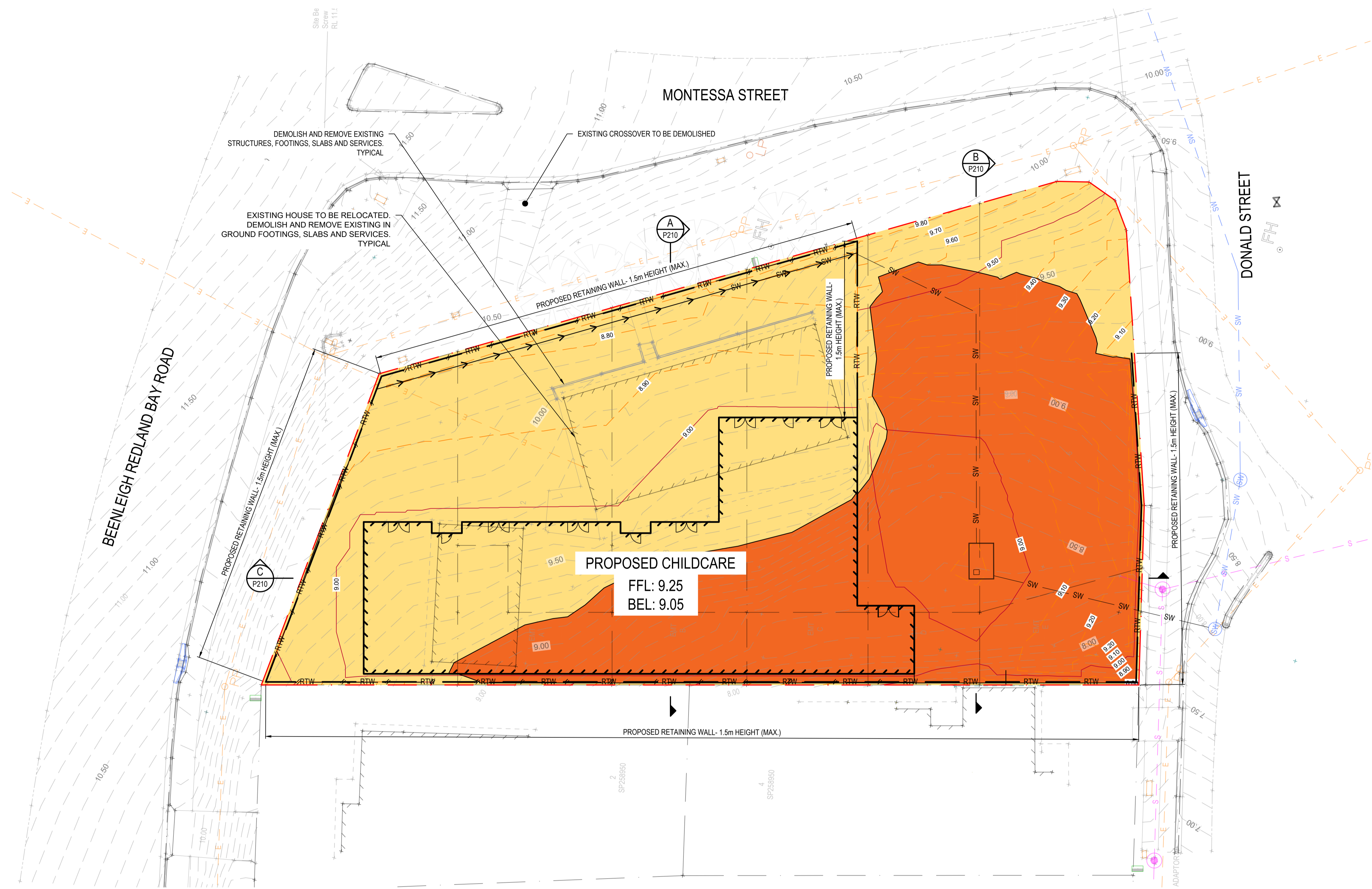

LAYOUT PLAN
SCALE 1:200

PLOTTED: 20.03.2023

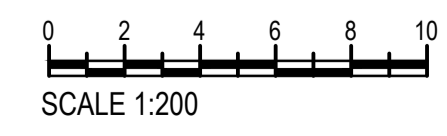
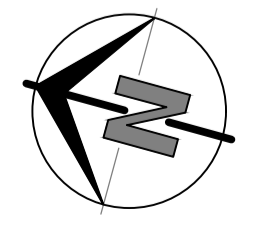

REV.	DATE	AMENDMENT	BY	APP
B	20.03.23	GENERAL AMENDMENTS	AL	AvT
A	08.02.23	ISSUE FOR APPROVAL	JT	AvT

VT CONSULTING ENGINEERS
 PO Box 26, Carina QLD 4152
 E: admin@vtce.com.au
 Ph: 1300 185 737
 W: vtce.com.au

CLIENT: **ACCORD**

SCALE: AS SHOWN	DRAWN: JT
SHEET SIZE: A1	DESIGN: ZL
DATUM: AHD	CHECKED: ZL
APPROVED:	

PROJECT: PROPOSED CHILDCARE DEVELOPMENT 153 BEENLEIGH REDLAND BAY ROAD, CORNUBIA
DRAWING TITLE: PRELIMINARY EARTHWORKS LAYOUT PLAN

JOB No.: 22396
DRAWING No.: P200 <small>PRELIMINARY</small>
REV.: B

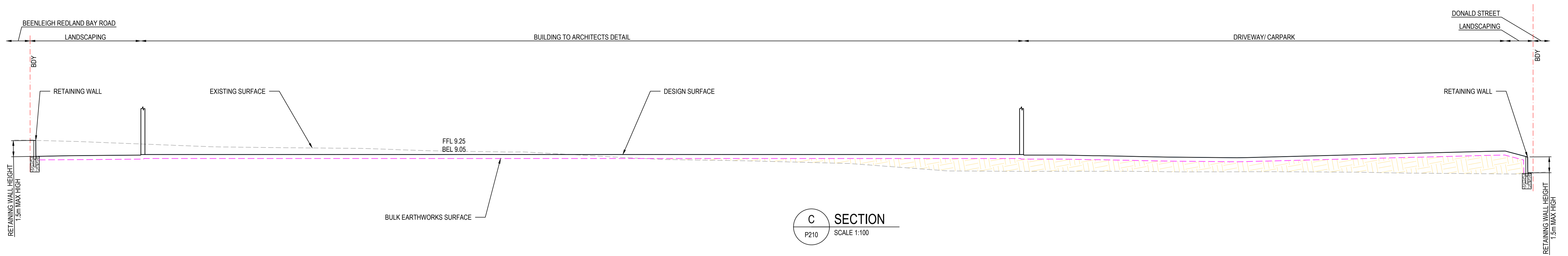
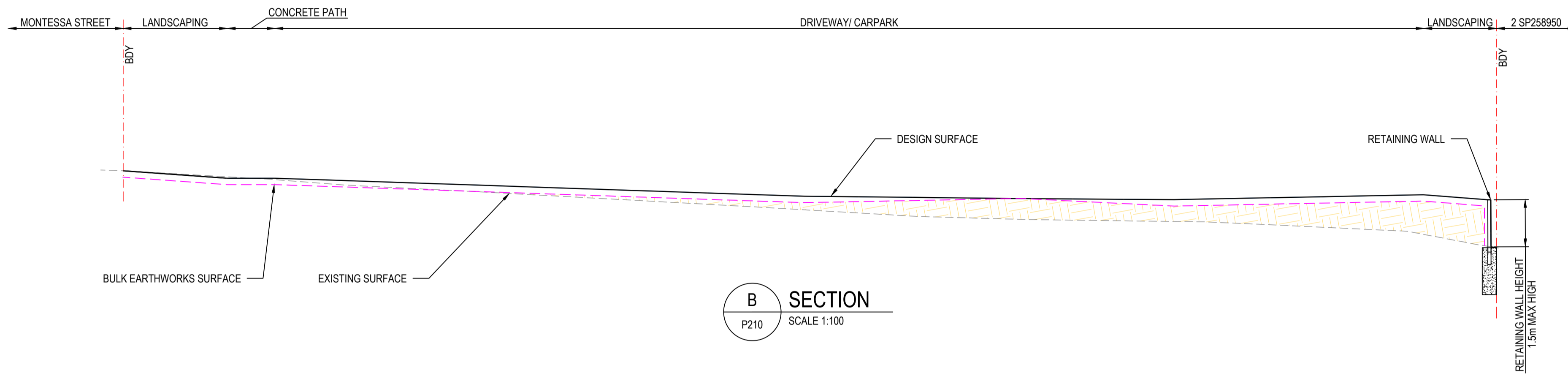
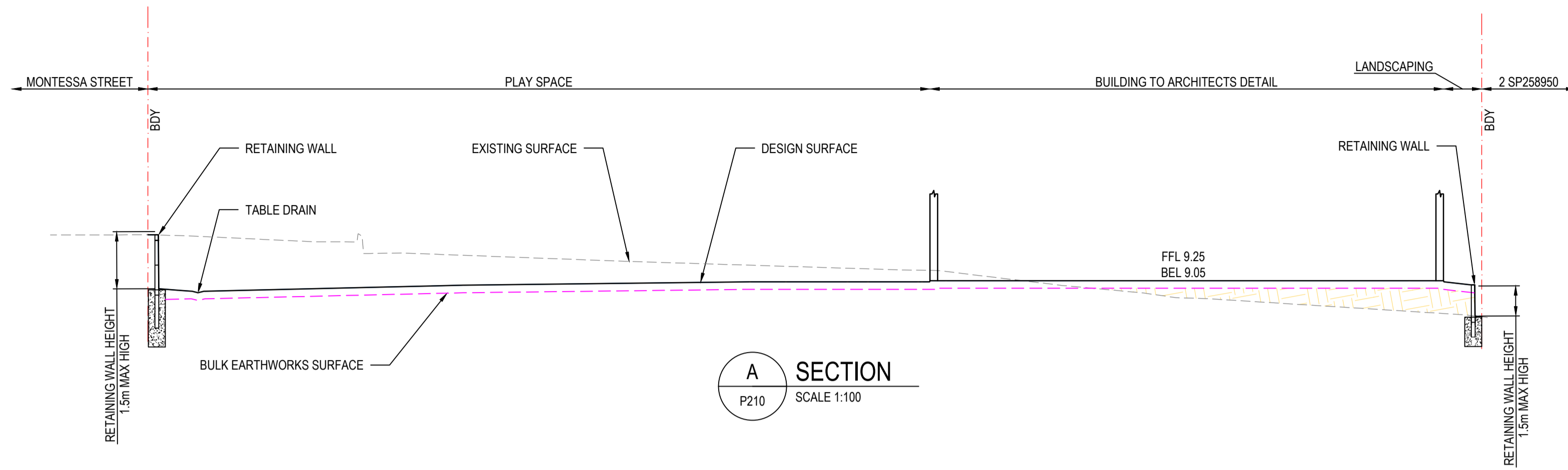

REV.	DATE	AMENDMENT	BY:	APP:
B	20.03.23	GENERAL AMENDMENTS	AL	AvT
A	08.02.23	ISSUE FOR APPROVAL	JT	AvT



SCALE: AS SHOWN	DRAWN: JT
SHEET SIZE: A1	DESIGN: ZL
DATUM: AHD	CHECKED: ZL
<small>COPYRIGHT: THIS DOCUMENT IS AND SHALL REMAIN THE PROPERTY OF VT CONSULTING ENGINEERS. THIS DOCUMENT MAY ONLY BE USED FOR THE PURPOSE FOR WHICH IT WAS COMMISSIONED AND IN ACCORDANCE WITH THE TERMS OF ENGAGEMENT UNAUTHORISED USE OF THIS DOCUMENT IN ANY FORM WHATSOEVER IS PROHIBITED. ©</small>	

PROJECT: PROPOSED CHILDCARE DEVELOPMENT 153 BEENLEIGH REDLAND BAY ROAD, CORNUBIA
DRAWING TITLE: PRELIMINARY EARTHWORKS SECTIONS

JOB No.: 22396
DRAWING No.: P210 <small>PRELIMINARY</small>
REV.: B

LEGEND

- EXISTING PROPERTY BOUNDARY
- EXISTING EASEMENT BOUNDARY
- EXISTING CONTOUR - MAJOR
- EXISTING CONTOUR - MINOR
- EXISTING BUILDING
- EXISTING KERB AND CHANNEL
- EXISTING KERB
- EXISTING RETAINING WALL
- EXISTING STORMWATER DRAINAGE
- EXISTING ROOFWATER DRAINAGE
- EXISTING SEWER
- EXISTING WATER
- EXISTING ELECTRICAL
- EXISTING ELEC. OVERHEAD
- EXISTING COMMUNICATIONS
- ABANDON EXISTING SERVICE
- PROPERTY BOUNDARY
- EASEMENT BOUNDARY
- CONTOUR - MAJOR
- CONTOUR - MINOR
- BUILDING
- EARTHWORKS TOP OF BATTER
- EARTHWORKS BOTTOM OF BATTER
- RTW
- RETAINING WALL
- SF
- SEDIMENT FENCE
- FENCE - TYPE 1
- KERB AND CHANNEL
- KERB
- STORMWATER DRAINAGE
- ROOFWATER DRAINAGE
- SUBSOIL DRAIN
- STORMWATER TABLE DRAIN
- SEWER
- WATER
- EXISTING SURFACE LEVEL (ESL)
- FINISHED SURFACE LEVEL (FSL)
- BULK EARTHWORKS LEVEL (BEL)

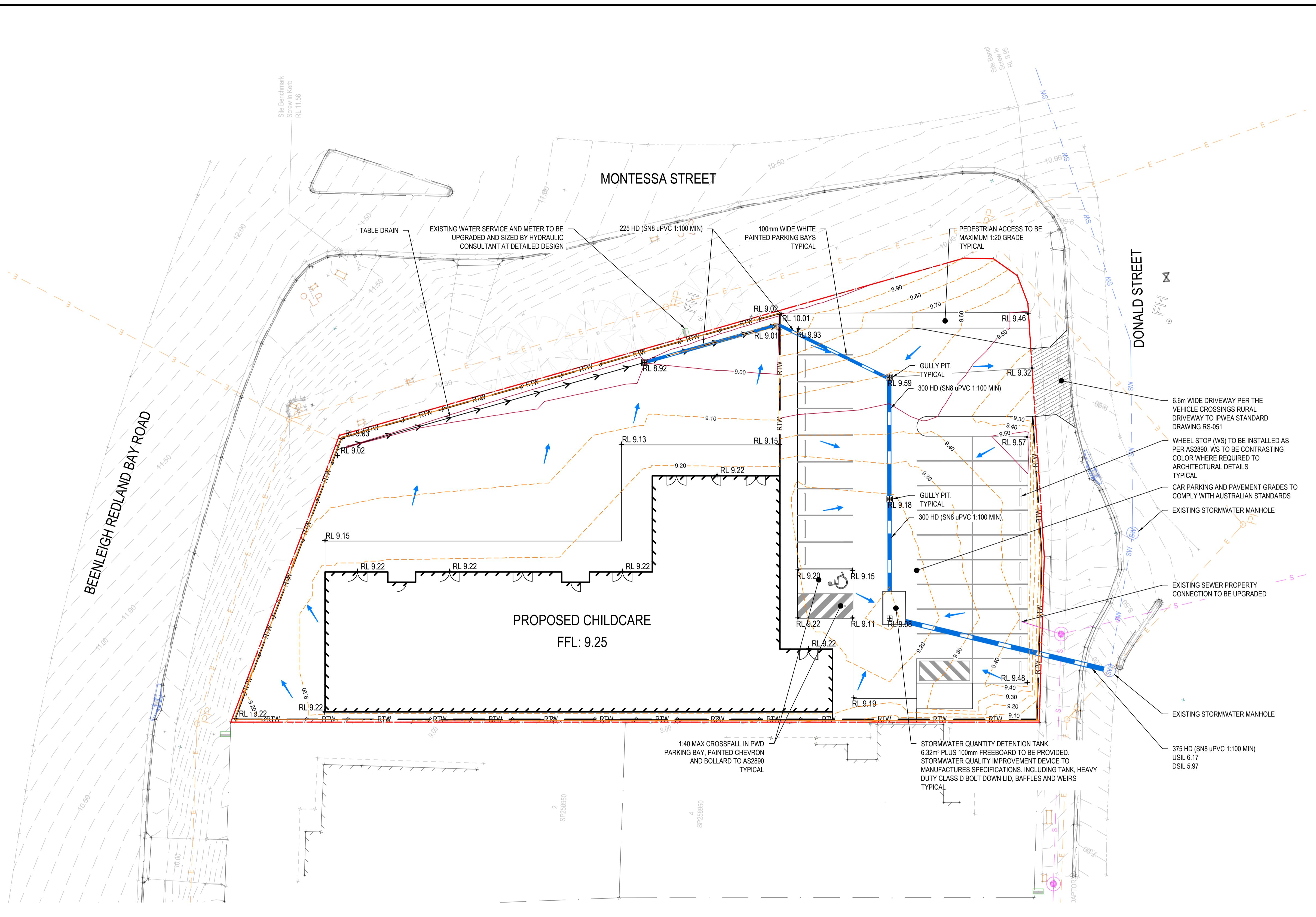

LAYOUT PLAN
SCALE 1:200

PLOTTED: 20.03.2023

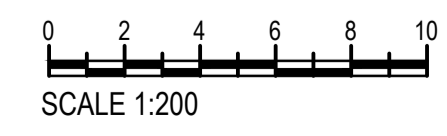
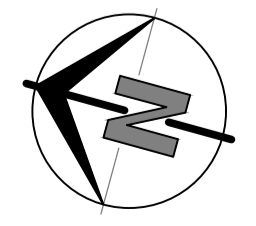

REV.	DATE	AMENDMENT	BY	APP
B	20.03.23	GENERAL AMENDMENTS	AL	AvT
A	08.02.23	ISSUE FOR APPROVAL	JT	AvT

VT CONSULTING ENGINEERS
 PO Box 26, Carina QLD 4152
 E: admin@vtce.com.au
 Ph: 1300 185 737
 W: vtce.com.au



SCALE: AS SHOWN	DRAWN: JT
SHEET SIZE: A1	DESIGN: ZL
DATUM: AHD	CHECKED: ZL
APPROVED:	

PROJECT:	PROPOSED CHILDCARE DEVELOPMENT 153 BEENLEIGH REDLAND BAY ROAD, CORNUBIA
DRAWING TITLE:	PRELIMINARY SERVICES LAYOUT PLAN

JOB No.:	22396
DRAWING No.:	P300
REV.:	B

Appendix B - IECA Erosion Hazard Assessment Form



Erosion Hazard Assessment Form

Condition	Points	Score	Trigger value
AVERAGE SLOPE OF DISTURBANCE AREA [1] <ul style="list-style-type: none"> not more than 3% [3% . 33H:1V] more than 3% but not more than 5% [5% = 20H:1V] more than 5% but not more than 10% [10% = 10H:1V] more than 10% but not more than 15% [15% . 6.7H:1V] more than 15% 	0 1 2 4 6	1	4
SOIL CLASSIFICATION GROUP (AS1726) [2] <ul style="list-style-type: none"> GW, GP, GM, GC SW, SP, OL, OH SM, SC, MH, CH ML, CL, or if <i>imported fill</i> is used, or if soils are untested 	0 1 2 3	3	
EMERSON (DISPERSION) CLASS NUMBER [3] <ul style="list-style-type: none"> Class 4, 6, 7, or 8 Class 5 Class 3, (default value if soils are untested) Class 1 or 2 	0 2 4 6	4	6
DURATION OF SOIL DISTURBANCE [4] <ul style="list-style-type: none"> not more than 1 month more than 1 month but not more than 4 months more than 4 months but not more than 6 months more than 6 months 	0 2 4 6	4	6
AREA OF DISTURBANCE [5] <ul style="list-style-type: none"> not more than 1000 m² more than 1000 m² but not more than 5000 m² more than 5000 m² but not more than 1 ha more than 1 ha but not more than 4 ha more than 4 ha 	0 1 2 4 6	1	4
WATERWAY DISTURBANCE [6] <ul style="list-style-type: none"> No disturbance to a watercourse, open drain or channel Involves disturbance to a constructed open drain or channel Involves disturbance to a natural watercourse 	0 1 2	0	2
REHABILITATION METHOD [7] Percentage of area (relative to total disturbance) revegetated by seeding without light mulching (i.e. worst-case revegetation method). <ul style="list-style-type: none"> not more than 1% more than 1% but not more than 5% more than 5% but not more than 10% more than 10% 	0 1 2 4	0	
RECEIVING WATERS [8] <ul style="list-style-type: none"> Saline waters only Freshwater body (e.g. creek or freshwater lake or river) 	0 2	2	
SUBSOIL EXPOSURE [9] <ul style="list-style-type: none"> No subsoil exposure except of service trenches Subsoils are likely to be exposed 	0 2	2	
EXTERNAL CATCHMENTS [10] <ul style="list-style-type: none"> No external catchment External catchment diverted around the soil disturbance External catchment not diverted around the soil disturbance 	0 1 2	0	
ROAD CONSTRUCTION [11] <ul style="list-style-type: none"> No road construction Involves road construction works 	0 2	0	
pH OF SOILS TO BE REVEGETATED [12] <ul style="list-style-type: none"> more than pH 5.5 but less than pH 8 other pH values, or if soils are untested 	0 1	1	
Total Score ^[13]		18	

Explanatory notes

Requirements: Specific issues or actions required by the proponent.

Warnings: Issues that should be considered by the proponent.

Comments: General information relating to the topic.

[1] **REQUIREMENTS:**

For sites with an average slope of proposed land disturbance greater than 10%, a preliminary ESCP must be submitted to the regulatory authority for approval during planning negotiations.

Proponents must demonstrate that adequate erosion and sediment control measures can be implemented on-site to effectively protect downstream environmental values.

If site or financial constraints suggest that it is not reasonable or practicable for the prescribed water quality objectives to be achieved for the proposal, then the proponent must demonstrate that alternative designs or construction techniques (e.g. pole homes, suspended slab) cannot reasonably be implemented on the site.

WARNINGS:

Steep sites usually require more stringent drainage and erosion controls than flatter grade sites.

COMMENTS:

The steeper the land, the greater the need for adequate drainage controls to prevent soil and mulch from being washed from the site.

[2] **REQUIREMENTS:**

If the actual soil K-factor is known from soil testing, then the Score shall be determined from Table 1.

If a preliminary ESCP is required during planning negotiations, then it must be demonstrated that adequate space is available for the construction and operation of any major sediment traps, including the provision for any sediment basins and their associated embankments and spillways. It must also be demonstrated that all reasonable and practicable measures can be taken to divert the maximum quantity of sediment-laden runoff (up to the specified design storm) to these sediment traps throughout the construction phase and until the contributing catchment is adequately stabilised against erosion.

WARNINGS:

The higher the point score, the greater the need to protect the soil from raindrop impact and thus the greater the need for effective erosion control measures. A point score of 2 or greater will require a greater emphasis to be placed on revegetation techniques that do not expose the soil to direct rainfall contact during vegetation establishment, e.g. turfing and *Hydromulching*.

COMMENTS:

Table 2 provides an *indication* of soil conditions likely to be associated with a particular Soil group based on a statistical analysis of soil testing across NSW. This table provides only an initial estimate of the likely soil conditions.

The left-hand-side of the table provides an indication of the type of sediment basin that will be required (Type C, F or D). The right-hand-side of the table provides an indication of the likely erodibility of the soil based on the Revised Universal Soil Loss Equation (RUSLE) K-factor.

Table 3 provides some general comments on the erosion potential of the various soil groups.

Table 1 – Score if soil K-factor is known

	RUSLE soil erodibility K-factor			
	K < 0.02	0.02<K<0.04	0.04<K<0.06	K > 0.06
Score	0	1	2	3

Table 2 – Statistical analysis of NSW soil data^[1]

Unified Soil Class System	Likely sediment basin classification (%)			Probable soil erodibility K-factor (%) ^[2]			
	Dry	Wet		Low	Moderate	High	Very High
	Type C	Type F	Type D	K < 0.02	0.02<K<0.04	0.04<K<0.06	K > 0.06
GM	30	58	12	12	51	26	12
GC	42	33	25	13	71	17	0
SW	40	48	12	49	39	12	0
SP	53	32	15	76	18	5	1
SM	21	67	12	26	48	25	1
SC	26	50	24	16	64	18	2
ML	5	63	32	4	35	45	16
CL	9	51	39	12	56	19	13
OL	2	80	18	34	61	5	1
MH	12	41	48	15	19	41	25
CH	5	44	51	39	43	11	7

Notes: [1] Analysis of soil data presented in Landcom (2004).

[2] Soil erodibility based on Revised Universal Soil Loss Equation (RUSLE) K-factor.

Unified Soil Classification System (USCS)

GW Well graded gravels, gravel-sand mixtures, little or no fines

GP Poorly graded gravels, gravel-sand mixture, little or no fines

GM Silty gravels, poorly graded gravel-sand-silt mixtures

GC Clayey gravels, poorly graded gravel-sand-clay mixtures

SW Well graded sands, gravelly sands, little or no fines

SP Poorly graded sands, gravelly sands, little or no fines

SM Silty sands, poorly graded sand-silt mixtures

SC Clayey sands, poorly graded sand-clay mixtures

ML Inorganic silts & very fine sands, rock flour, silty or clayey fine sands with slight plasticity

CL Inorganic clays, low–medium plasticity, gravelly clays, sandy clays, silty clays, lean clays

OL Organic silts and organic silt-clays of low plasticity

MH Inorganic silts, micaceous or diatomaceous fine sandy or silty soils, elastic silts

CH Inorganic clays of high plasticity, fat clays

OH Organic clays of medium to high plasticity

Table 3 – Typical properties of various soil groups ^[1]

Soil Groups	Typical properties ^[2]
GW, GP	<ul style="list-style-type: none"> • Low erodibility potential.
GM, GC	<ul style="list-style-type: none"> • Low to medium erodibility potential. • May create turbid runoff if disturbed as a result of the release of silt and clay particles.
SW, SP	<ul style="list-style-type: none"> • Low to medium erodibility potential.
SM, SC	<ul style="list-style-type: none"> • Medium erodibility potential. • May create turbid runoff if disturbed as a result of the release of silt and clay particles.
MH, CH	<ul style="list-style-type: none"> • Highly variable (low to high) erodibility potential. • Will generally create turbid runoff if disturbed.
ML, CL	<ul style="list-style-type: none"> • High erodibility potential. • Tendency to be dispersive. • May create some turbidity in runoff if disturbed.

Note: [1] After Soil Services & NSW DLWC (1998).

[2] Any soil can represent a high erosion risk if the binding clays or silts are unstable.

Table 4 provides **general** guidelines on the suitability of various soil groups to various engineering applications.

Table 4 – Engineering suitability based on Unified Soil Classification ^[1]

Unified Soil Class	USC Group	Embankments		Fill	Slope stability	Untreated roads
		Water retaining	Non water retaining			
Well graded gravels	GW	Unsuitable	Excellent	Excellent	Excellent	Average
Poorly graded gravel	GP	Unsuitable	Average	Excellent	Average	Unsuitable
Silty gravels	GM	Unsuitable	Average	Good	Average	Average
Clayey gravels	GC	Suitable	Average	Good	Average	Excellent
Well graded sands	SW	Unsuitable	Excellent	Excellent	Excellent	Average
Poorly graded sands	SP	Unsuitable	Average	Good	Average	Unsuitable
Silty sands	SM	Suitable ^[2]	Average	Average	Average	Poor
Clayey sands	SC	Suitable	Average	Average	Average	Good
Inorganic silts	ML	Unsuitable	Poor	Average	Poor	Unsuitable
Inorganic clays	CL	Suitable ^[2]	Good	Average	Good	Poor
Organic silts	OL	Unsuitable	Unsuitable	Poor	Unsuitable	Unsuitable
Inorganic silts	MH	Unsuitable	Poor	Poor	Poor	Unsuitable
Inorganic clays	CH	Suitable ^[2]	Average	Unsuitable	Average	Unsuitable
Organic clays	OH	Unsuitable	Unsuitable	Unsuitable	Unsuitable	Unsuitable
Highly organic soils	Pt	Unsuitable	Unsuitable	Unsuitable	Unsuitable	Unsuitable

Notes: [1] Modified from Hazelton & Murphy (1992)

[2] Suitable only after modifications to soil such as compaction and/or erosion protection

- [3] If the soils have not been tested for Emerson Class, then adopt a score of 4.

REQUIREMENTS:

Works proposed on sites containing Emerson Class 1 or 2 soils have a very high pollution potential and must submit a conceptual ESCP to the regulatory authority for review and/or approval (as required by the authority) during planning negotiations.

WARNINGS:

Class 3 and 5 soils disturbed by cut and fill operations or construction traffic are highly likely to discolour stormwater (i.e. cause turbid runoff). Chemical stabilisation will likely be required if these soils are placed immediately adjacent to a retaining wall. Any disturbed Class 1, 2, 3 and 5 soils that are to be revegetated must be covered with a non-dispersive topsoil as soon as possible (unless otherwise agreed by the regulatory authority).

Class 1 and 2 soils are highly likely to discolour (pollute) stormwater if exposed to rainfall or flowing water. Treatment of these soils with gypsum (or other suitable substance) will most likely be required. These soils should not be placed directly behind a retaining wall unless it has been adequately treated (stabilised) or covered with a non-dispersible soil.

- [4] The duration of disturbance refers to the total duration of soil exposure to rainfall up until a time when there is at least 70% coverage of all areas of soil.

REQUIREMENTS:

All land developments with an expected soil disturbance period greater than 6 months must submit a conceptual ESCP to the regulatory authority for review and/or approval (as required by the authority) during planning negotiations.

COMMENTS:

Construction periods greater than 3 months will generally experience at least some significant storm events, independent of the time of year that the construction (soil disturbance) occurs.

- [5] **REQUIREMENTS:**

Development proposals with an expected soil disturbance in excess of 1ha must submit a conceptual ESCP to the regulatory authority for review and/or approval (as required by the regulatory authority) during planning negotiations.

The area of disturbance refers to the total area of soil exposed to rainfall or dust-producing winds either as a result of:

- (a) the removal of ground cover vegetation, mulch or sealed surfaces;
- (b) past land management practices;
- (c) natural conditions.

WARNINGS:

A *Sediment Basin* will usually be required if the disturbed area exceeds 0.25ha (2500m²) within any sub-catchment (i.e. land flowing to one outlet point).

COMMENTS:

For soil disturbances greater than 0.25ha, the revegetation phase should be staged to minimise the duration for which soils are exposed to wind, rain and concentrated runoff.

[6] REQUIREMENTS:

All developments that involve earthworks or construction within a natural watercourse (whether that watercourse is in a natural or modified condition) must submit a conceptual ESCP to the regulatory authority for review and/or approval (as required by the regulatory authority) during planning negotiations.

Permits and/or licences may be required from the State Government, including possible submission of the ESCP to the relevant Government department.

[7] REQUIREMENTS:

No areas of soil disturbance shall be left exposed to rainfall or dust-producing winds at the end of a development without an adequate degree of protection and/or an appropriate action plan for the establishment of at least 70% cover.

COMMENTS:

Grass seeding without the application of a light mulch cover is considered the least favourable revegetation technique. A light mulch cover is required to protect the soil from raindrop impact, excessive temperature fluctuations, and the loss of essential soil moisture.

[8] COMMENTS:

All receiving waters can be adversely affected by unnatural quantities of sediment-laden runoff. Freshwater ecosystems are generally more susceptible to ecological harm resulting from the inflow of fine or dispersible clays than saline water bodies. The further inland a land disturbance is, the greater the potential for the released sediment to cause environmental harm as this sediment travels towards the coast.

For the purpose of this clause it is assumed that all sediment-laden runoff will eventually flow into saline waters. Thus, sediment-laden discharges that flow first into freshwater are likely to adversely affect both fresh and saline water bodies and are therefore considered potentially more damaging to the environment.

This clause does **not** imply that sediment-laden runoff will not cause harm to saline waters.

[9] COMMENTS:

This clause refers to subsoils exposed during the construction phase either as a result of past land practices or proposed construction activities. The exposure of subsoils resulting from the excavation of minor service trenches should not be considered.

[10] WARNINGS:

The greater the extent of external catchment, the greater the need to divert up-slope stormwater runoff around any soil disturbance.

COMMENTS:

The ability to separate "clean" (i.e. external catchment) stormwater runoff from "dirty" site runoff can have a significant effect on the size, efficiency and cost of the temporary drainage, erosion, and sediment control measures.

[11] REQUIREMENTS:

Permission must be obtained from the owner of a road reserve before placing any erosion and sediment control measures within the road reserve.

WARNINGS:

Few sediment control techniques work efficiently when placed on a road and/or around roadside stormwater inlets. Great care must be taken if sediment control measures are located on a public roadway, specifically:

- safety issues relating to road users;
- the risk of causing flooding on the road or within private property.

The construction of roads (whether temporary or permanent) will usually modify the flow path of stormwater runoff. This can affect how “dirty” site runoff is directed to the sediment control measures.

COMMENTS:

“On-road” sediment control devices are at best viewed as secondary or supplementary sediment control measures. Only in special cases and/or on very small projects (e.g. kerb and channel replacement) might these controls be considered as the “primary” sediment control measure.

[12] WARNINGS:

Soils with a pH less than 5.5 or greater than 8 will usually require treatment in order to achieve satisfactory revegetation. Soils with a pH of less than 5 (whether naturally acidic or in acid sulfate soil areas) may also limit the choice of chemical flocculants (e.g. Alum) for use in the flocculation of *Sediment Basins*.

[13] REQUIREMENTS:

A preliminary ESCP must be submitted to the local government for approval during the planning phase for any development that obtains a total point score of 17 or greater or when any trigger value is scored or exceeded.

Appendix C - IECA (Australasia) Standard Drawings

Available from: <http://www.austieca.com.au/publications/book-6-standard-drawings>



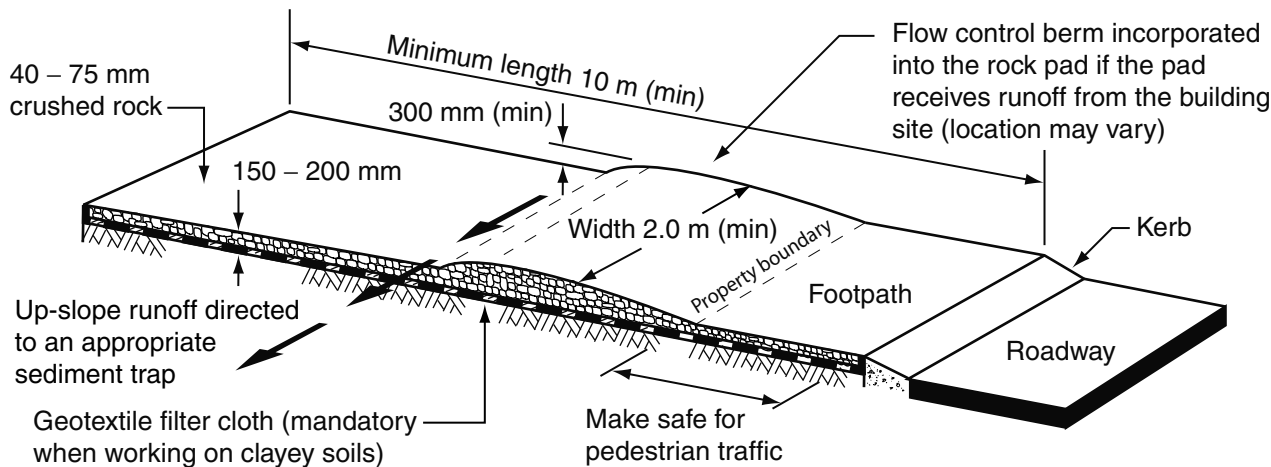

(a) Rock entry/exit pad for building sites

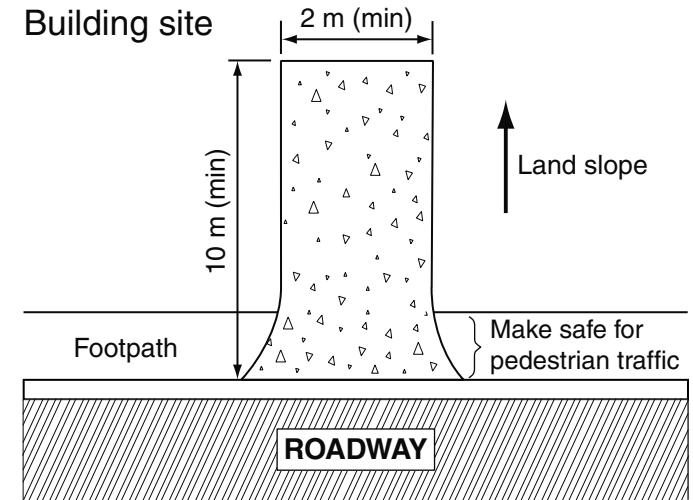

(b) Rock pad sloping away from road

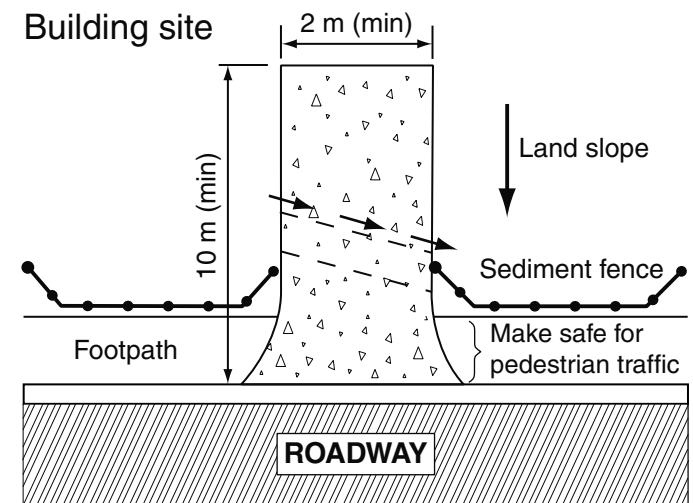

(c) Rock pad sloping towards the road

CONSTRUCTION NOTES:

MATERIALS

ROCK: WELL GRADED, HARD, ANGULAR, EROSION RESISTANT ROCK, NOMINAL DIAMETER OF 40 TO 75mm.

FOOTPATH STABILISING AGGREGATE: 25 TO 50mm GRAVEL OR AGGREGATE (IF REQUIRED).

GEOTEXTILE FABRIC: HEAVY-DUTY, NEEDLE-PUNCHED, NON-WOVEN FILTER CLOTH ('BIDIM' A24 OR EQUIVALENT).

INSTALLATION

1. INSPECT ALL SITE ENTRY AND EXIT POINTS PRIOR TO FORECAST RAIN, DAILY DURING EXTENDED PERIODS OF RAINFALL, AFTER RUNOFF-PRODUCING RAINFALL, OR OTHERWISE AT FORTNIGHTLY INTERVALS.

2. IF SAND, SOIL, SEDIMENT OR MUD IS TRACKED OR WASHED ONTO THE ADJACENT SEALED ROADWAY, THEN SUCH MUST BE PHYSICALLY REMOVED, FIRST USING A SQUARE-EDGED SHOVEL, AND THEN A

STIFF-BRISTLED BROOM, AND THEN BY A MECHANICAL VACUUM UNIT, IF AVAILABLE.

3. IF NECESSARY FOR SAFETY REASONS, THE ROADWAY SHALL ONLY BE WASHED CLEAN AFTER ALL REASONABLE EFFORTS HAVE BEEN TAKEN TO SHOVEL AND SWEEP THE MATERIAL FROM THE ROADWAY.

4. WHEN THE VOIDS BETWEEN THE ROCK BECOMES FILLED WITH MATERIAL AND THE EFFECTIVENESS OF THE ROCK PAD IS REDUCED TO A POINT WHERE SEDIMENT IS BEING TRACKED OFF THE SITE, A NEW 100mm LAYER OF ROCK MUST BE ADDED AND/OR THE ROCK PAD MUST BE EXTENDED.

5. ENSURE ANY ASSOCIATED DRAINAGE CONTROL MEASURES (e.g. FLOW CONTROL BERM) ARE MAINTAINED IN ACCORDANCE WITH THEIR DESIRED OPERATIONAL CONDITION.

6. DISPOSE OF SEDIMENT AND DEBRIS IN A MANNER THAT WILL NOT CREATE AN EROSION OR POLLUTION HAZARD.

Drawn:	Date:		
GMW	May-10	Rock Pads for Building Sites	ESC-01

MATERIALS

FABRIC (LIGHT TRAFFIC AREAS):

HEAVY-DUTY, NEEDLE-PUNCHED, NON-WOVEN FILTER CLOTH ('BIDIM' A34 OR EQUIVALENT).

FABRIC (HEAVY TRAFFIC AREAS):

POLY-PROPYLENE, POLYAMIDE, NYLON, POLYESTER, OR POLYETHYLENE WOVEN OR NON-WOVEN REINFORCED FABRIC. THE FABRIC WIDTH SHOULD BE AT LEAST 700mm, WITH A MINIMUM UNIT WEIGHT OF 140g/m². FABRICS SHOULD CONTAIN ULTRAVIOLET INHIBITORS AND STABILISERS TO PROVIDE A MINIMUM OF 6 MONTHS OF USEABLE CONSTRUCTION LIFE (ULTRAVIOLET STABILITY EXCEEDING 70%).

INSTALLATION

1. REFER TO APPROVED PLANS FOR LOCATION AND DIMENSIONAL DETAILS. IF THERE ARE QUESTIONS OR PROBLEMS WITH THE LOCATION, DIMENSIONS OR METHOD OF INSTALLATION CONTACT THE ENGINEER OR RESPONSIBLE ON-SITE OFFICER FOR ASSISTANCE.

2. ENSURE THAT THE INSTALLATION OF THE SEDIMENT TRAP WILL NOT CAUSE UNDESIRABLE SAFETY OR FLOODING ISSUES.

3. SELECT THE APPROPRIATE FABRIC FOR THE SITE CONDITIONS.

4. WRAP THE FABRIC AROUND OR OVER THE STORMWATER INLET GRATE IN SUCH A MANNER THAT PREVENTS ANY WATER ENTERING THE STORMWATER INLET WITHOUT PASSING THROUGH THE FABRIC.

5. ENSURE ALL OTHER FLOW ENTRY POINTS ARE COVERED WITH FABRIC SUCH THAT WATER CANNOT ENTER THE STORMWATER INLET WITHOUT PASSING THROUGH A SUITABLE FILTER.

6. TAKE ALL NECESSARY MEASURE TO MINIMISE SAFETY OR FLOODING RISK CAUSED BY OPERATION OF THE SEDIMENT TRAP.

MAINTENANCE

1. INSPECT THE BARRIER AFTER EACH RUNOFF-PRODUCING RAINFALL EVENT AND MAKE REPAIRS AS NEEDED TO THE SEDIMENT TRAP.

2. REMOVE COLLECTED SEDIMENT AND DISPOSE OF IN A SUITABLE MANNER THAT WILL NOT CAUSE AN EROSION OR POLLUTION HAZARD.

3. REPLACE THE FABRIC IF IT IS TORN OR DAMAGED.

4. SEDIMENT DEPOSITS SHOULD BE REMOVED IMMEDIATELY IF THEY REPRESENT A SAFETY RISK.

REMOVAL

1. WHEN THE UP-SLOPE DRAINAGE AREA HAS BEEN STABILISED, REMOVE ALL MATERIALS INCLUDED DEPOSITED SEDIMENT AND DISPOSE OF IN A SUITABLE MANNER THAT WILL NOT CAUSE AN EROSION OR POLLUTION HAZARD.

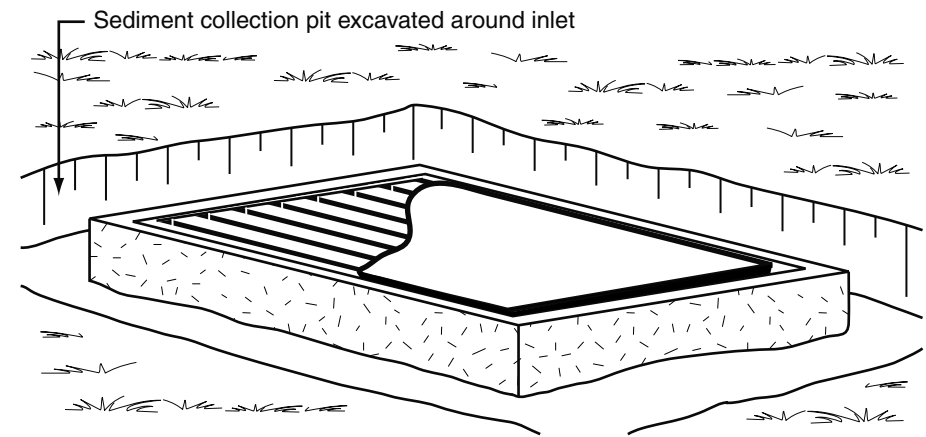

(a) Fabric wrap drop inlet protection with trench

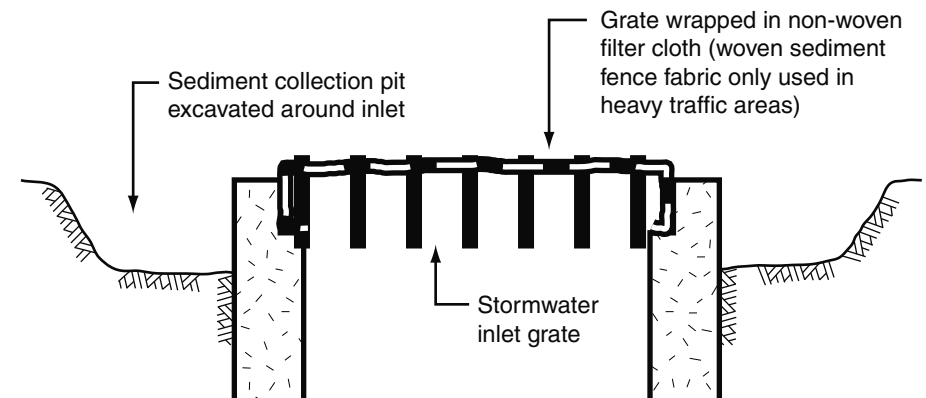

(b) Typical details of excavated sediment collection trench

Drawn: GMW	Date: May-10	Grated Stormwater (Field) Inlet Sediment Trap	ESC-02
---------------	-----------------	--	--------

MATERIALS

SOCKS: MINIMUM 200mm DIAMETER SYNTHETIC OR BIODEGRADABLE TUBES MANUFACTURED FROM NON-WOVEN OR COMPOSITE FABRIC SUITABLE FOR THE 'FILTRATION' OF COARSE SEDIMENTS.

FILL MATERIAL: STRAW, CANE MULCH, COMPOSTED MATERIAL (AS4454), COARSE SAND, OR CLEAN AGGREGATE.

STAKES: MINIMUM 25 x 25mm TIMBER.

INSTALLATION

1. REFER TO APPROVED PLANS FOR LOCATION AND INSTALLATION DETAILS. IF THERE ARE QUESTIONS OR PROBLEMS WITH THE LOCATION, DIMENSIONS OR METHOD OF INSTALLATION CONTACT THE ENGINEER OR RESPONSIBLE ON-SITE OFFICER FOR ASSISTANCE.

2. ENSURE THE SOCKS ARE PLACED INDIVIDUALLY OR COLLECTIVELY (AS A SINGLE SEDIMENT TRAP) SUCH THAT:

- (i) LEAKAGE AROUND OR UNDER THE SOCKS IS MINIMISED;
- (ii) ADJOINING SOCKS ARE TIGHTLY BUTTED OR OVERLAPPED AT LEAST 450mm;
- (iii) THE SURFACE AREA OF POTENTIAL WATER PONDING UP-SLOPE OF EACH SEDIMENT TRAP IS MAXIMISED;
- (iv) TO THE MAXIMUM DEGREE PRACTICAL, ALL SEDIMENT-LADEN WATER WILL PASS THROUGH THE FORMED POND BEFORE FLOWING OVER THE DOWN-SLOPE END OF THE SEDIMENT TRAP.

3. WHEN PLACED ACROSS THE INVERT OF MINOR DRAINS, ENSURE THE SOCKS ARE PLACED SUCH THAT:

- (i) THE CREST OF THE DOWNSTREAM SOCK IS LEVEL WITH THE CHANNEL INVERT AT THE IMMEDIATE UPSTREAM SOCK (IF ANY);

- (ii) EACH SOCK EXTENDS UP THE CHANNEL BANKS SUCH THAT THE CREST OF THE SOCK AT ITS LOWEST POINT IS LOWER THAN GROUND LEVEL AT EITHER END OF THE SOCK.

4. IF STAKES ARE REQUIRED TO ANCHOR THE SOCKS, THEIR SPACING DOES NOT EXCEEDING 1.2m OR SIX TIMES THE SOCK DIAMETER (WHICHEVER IS THE LESSER). A MAXIMUM STAKE SPACING OF 0.3m APPLIES WHEN USED TO FORM CHECK DAMS.

MAINTENANCE

1. INSPECT ALL FILTER SOCKS PRIOR TO FORECAST RAIN, DAILY DURING EXTENDED PERIODS OF RAINFALL, AFTER SIGNIFICANT RUNOFF PRODUCING STORMS OR OTHERWISE AT WEEKLY INTERVALS.

2. REPAIR OR REPLACE DAMAGED SOCKS.

3. THE BULK OF THE SEDIMENT COLLECTED BEHIND THE FILTER SOCKS SHOULD BE REMOVED BY SHOVEL AFTER EACH STORM EVENT.

4. REMOVE COLLECTED SEDIMENT AND DISPOSE OF IN A SUITABLE MANNER THAT WILL NOT CAUSE AN EROSION OR POLLUTION HAZARD.

REMOVAL

1. ALL SAND, SOIL, SEDIMENT OR MUD MUST BE PHYSICALLY REMOVED FROM SEALED SURFACES, FIRST USING A SQUARE-EDGED SHOVEL, AND THEN A STIFF-BRISTLED BROOM, AND THEN BY A MECHANICAL VACUUM UNIT, IF AVAILABLE.

2. IF NECESSARY FOR SAFETY REASONS, THE SEALED SURFACE SHALL ONLY BE

WASHED CLEAN AFTER ALL REASONABLE EFFORTS HAVE BEEN TAKEN TO SHOVEL AND SWEEP THE MATERIAL FROM THE SURFACE.

3. DISPOSE OF COLLECTED SEDIMENT IN A SUITABLE MANNER THAT WILL NOT CAUSE AN EROSION OR POLLUTION HAZARD.

4. ALL SYNTHETIC (PLASTIC) MESH OR OTHER NON READILY BIODEGRADABLE MATERIAL MUST BE REMOVED FROM THE SITE ONCE THE SLOPE OR DRAIN IS STABILISED, OR THE SOCKS HAVE DETERIORATED TO A POINT WHERE THEY ARE NO LONGER PROVIDING THEIR INTENDED DRAINAGE OR SEDIMENT CONTROL FUNCTION.

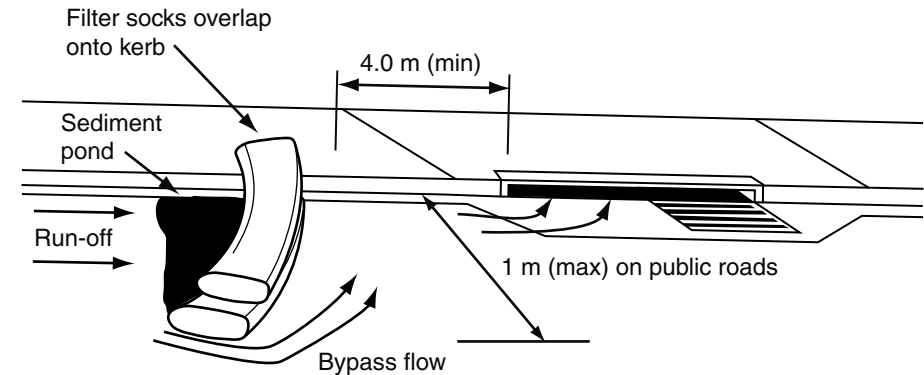

(a) On-grade kerb inlet sediment trap

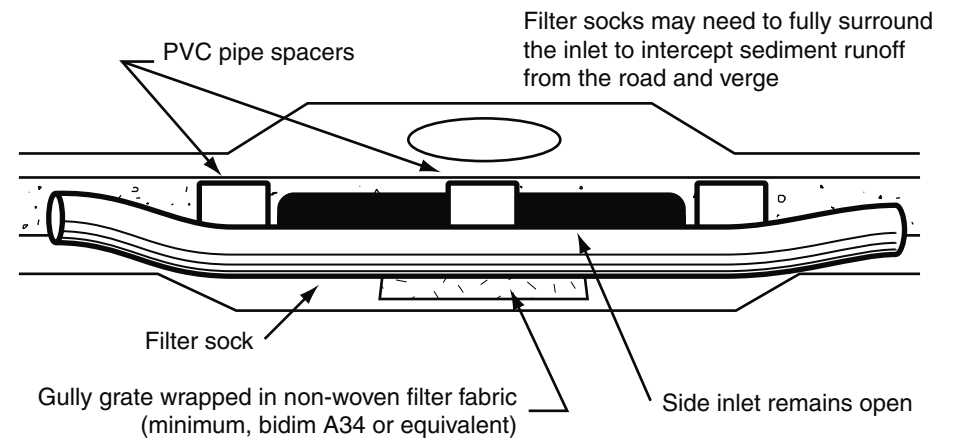

(b) Sag inlet sediment trap

Drawn:	Date:		
GMW	Dec-09	Kerb Inlet Sediment Traps	ESC-03

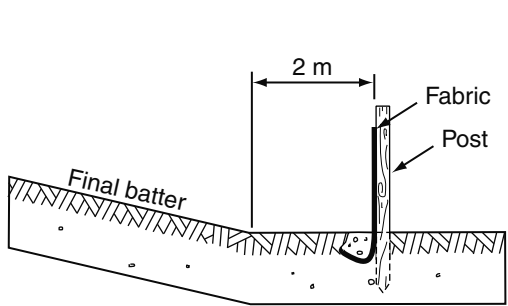

(a) Location of fence relative to base of slope

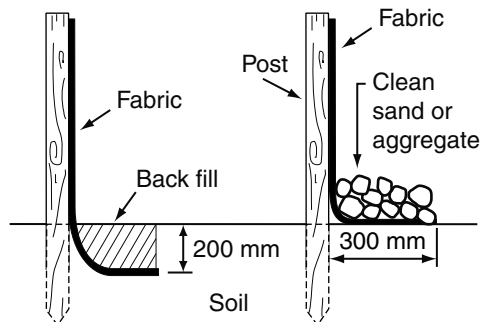

(b) Anchoring base of fabric

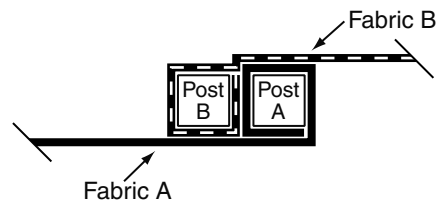

Fabric to fold around each stake one full turn.
Stake B to be drive tightly against Stake A.
The tops of both stakes to be secured with wire.

(c) Joining fabric - Method 1

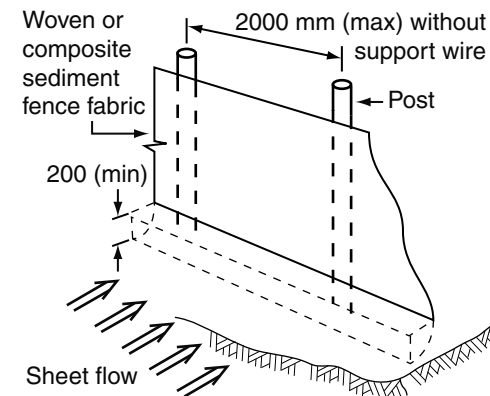

(d) Installation without backing support

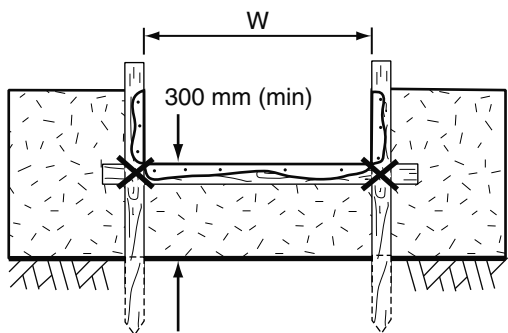

(e) Spill-through weir

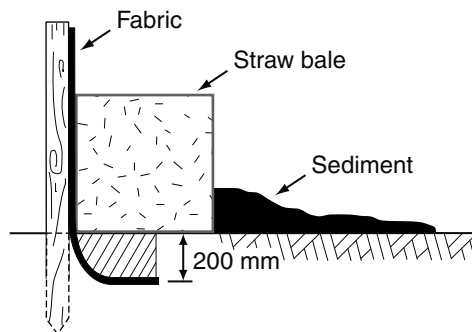

(f) Placement of up-slope straw bale

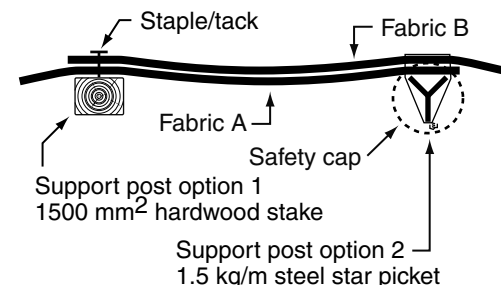

(g) Joining fabric - Method 2

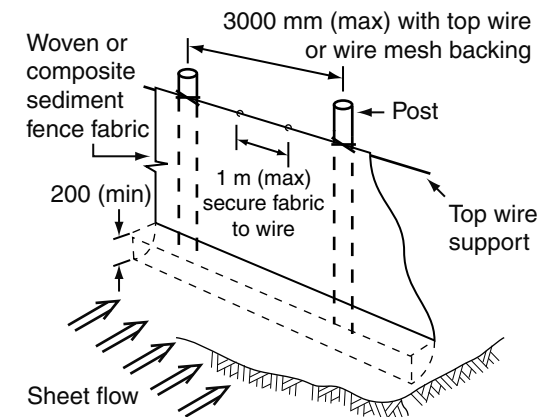

(h) Installation with top wire support

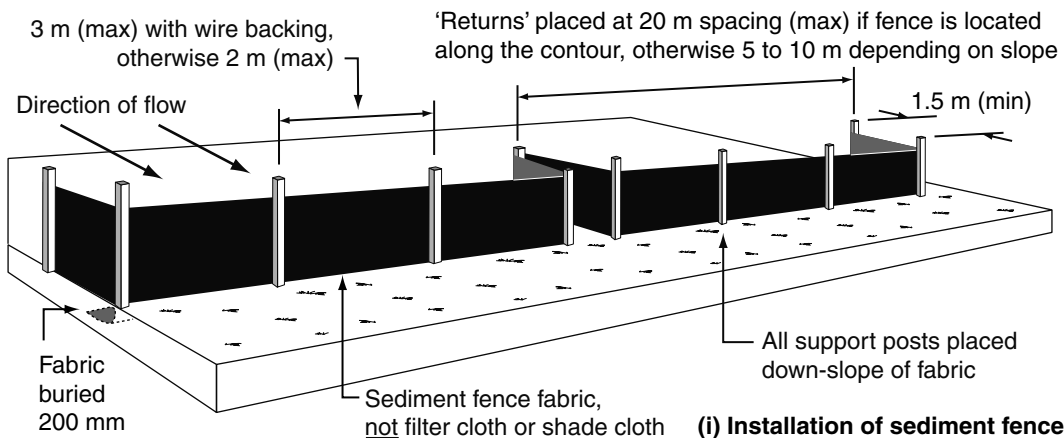

(i) Installation of sediment fence

Notes:

1. Sediment fence to be installed along a line of constant ground elevation wherever practical.
2. Both end of the sediment fence to extend up the slope at least 1m.
3. Support post to be spaced a maximum 2m unless the fence is supported by a top wire or wire mesh backing, in which case 3m maximum spacing.
4. Fence 'returns' shall be installed at maximum 20m spacing if fence is installed along the contour, otherwise 5 to 10m maximum spacing.
5. Minimum 4 staples or tie wires per stake.

Drawn:	Date:		
GMW	Dec-09	Sediment Fence	ESC-04

MATERIALS

FABRIC: POLYPROPYLENE, POLYAMIDE, NYLON, POLYESTER, OR POLYETHYLENE WOVEN OR NON-WOVEN FABRIC, AT LEAST 700mm IN WIDTH AND A MINIMUM UNIT WEIGHT OF 140g/m². ALL FABRICS TO CONTAIN ULTRAVIOLET INHIBITORS AND STABILISERS TO PROVIDE A MINIMUM OF 6 MONTHS OF USEABLE CONSTRUCTION LIFE (ULTRAVIOLET STABILITY EXCEEDING 70%).

FABRIC REINFORCEMENT: WIRE OR STEEL MESH MINIMUM 14-GAUGE WITH A MAXIMUM MESH SPACING OF 200mm.

SUPPORT POSTS/STAKES: 1500mm² (MIN) HARDWOOD, 2500mm² (MIN) SOFTWOOD, OR 1.5kg/m (MIN) STEEL STAR PICKETS SUITABLE FOR ATTACHING FABRIC.

INSTALLATION

1. REFER TO APPROVED PLANS FOR LOCATION, EXTENT, AND REQUIRED TYPE OF FABRIC (IF SPECIFIED). IF THERE ARE QUESTIONS OR PROBLEMS WITH THE LOCATION, EXTENT, FABRIC TYPE, OR METHOD OF INSTALLATION CONTACT THE ENGINEER OR RESPONSIBLE ON-SITE OFFICER FOR ASSISTANCE.

2. TO THE MAXIMUM DEGREE PRACTICAL, AND WHERE THE PLANS ALLOW, ENSURE THE FENCE IS LOCATED:

- (i) TOTALLY WITHIN THE PROPERTY BOUNDARIES;
- (ii) ALONG A LINE OF CONSTANT ELEVATION WHEREVER PRACTICAL;
- (iii) AT LEAST 2m FROM THE TOE OF ANY FILLING OPERATIONS THAT MAY RESULT IN SHIFTING SOIL/FILL DAMAGING THE FENCE.

3. INSTALL RETURNS WITHIN THE FENCE AT MAXIMUM 20m INTERVALS IF THE FENCE IS INSTALLED ALONG THE CONTOUR, OR 5 TO 10m MAXIMUM SPACING (DEPENDING ON SLOPE) IF THE FENCE IS INSTALLED AT AN ANGLE TO THE CONTOUR. THE 'RETURNS' SHALL CONSIST OF EITHER:

- (i) V-SHAPED SECTION EXTENDING AT LEAST 1.5m UP THE SLOPE; OR
- (ii) SANDBAG OR ROCK/AGGREGATE CHECK

DAM A MINIMUM 1/3 AND MAXIMUM 1/2 FENCE HEIGHT, AND EXTENDING AT LEAST 1.5m UP THE SLOPE.

4. ENSURE THE EXTREME ENDS OF THE FENCE ARE TURNED UP THE SLOPE AT LEAST 1.5m, OR AS NECESSARY, TO MINIMISE WATER BYPASSING AROUND THE FENCE.

5. ENSURE THE SEDIMENT FENCE IS INSTALLED IN A MANNER THAT AVOIDS THE CONCENTRATION OF FLOW ALONG THE FENCE, AND THE UNDESIRABLE DISCHARGE OF WATER AROUND THE ENDS OF THE FENCE.

6. IF THE SEDIMENT FENCE IS TO BE INSTALLED ALONG THE EDGE OF EXISTING TREES, ENSURE CARE IS TAKEN TO PROTECT THE TREES AND THEIR ROOT SYSTEMS DURING INSTALLATION OF THE FENCE. DO NOT ATTACH THE FABRIC TO THE TREES.

7. UNLESS DIRECTED BY THE SITE SUPERVISOR OR THE APPROVED PLANS, EXCAVATE A 200mm WIDE BY 200mm DEEP TRENCH ALONG THE PROPOSED FENCE LINE, PLACING THE EXCAVATED MATERIAL ON THE UP-SLOPE SIDE OF THE TRENCH.

8. ALONG THE LOWER SIDE OF THE TRENCH, APPROPRIATELY SECURE THE STAKES INTO THE GROUND SPACED NO GREATER THAN 3m IF SUPPORTED BY A TOP SUPPORT WIRE OR WEIR MESH BACKING, OTHERWISE NO GREATER THAN 2m.

9. IF SPECIFIED, SECURELY ATTACH THE SUPPORT WIRE OR MESH TO THE UP-SLOPE SIDE OF THE STAKES WITH THE MESH EXTENDING AT LEAST 200mm INTO THE EXCAVATED TRENCH. ENSURE THE MESH AND FABRIC IS ATTACHED TO THE UP-SLOPE SIDE OF THE STAKES EVEN WHEN DIRECTING A FENCE AROUND A CORNER OR SHARP CHANGE OF DIRECTION.

10. WHEREVER POSSIBLE, CONSTRUCT THE SEDIMENT FENCE FROM A CONTINUOUS ROLL OF FABRIC. TO JOIN FABRIC EITHER:
(i) ATTACH EACH END TO TWO OVERLAPPING STAKES WITH THE FABRIC FOLDING AROUND THE ASSOCIATED STAKE ONE TURN, AND WITH

THE TWO STAKES TIED TOGETHER WITH WIRE; OR
(ii) OVERLAP THE FABRIC TO THE NEXT ADJACENT SUPPORT POST.

11. SECURELY ATTACH THE FABRIC TO THE SUPPORT POSTS USING 25 X 12.5mm STAPLES, OR TIE WIRE AT MAXIMUM 150mm SPACING.

12. SECURELY ATTACH THE FABRIC TO THE SUPPORT WIRE/MESH (IF ANY) AT A MAXIMUM SPACING OF 1m.

13. ENSURE THE COMPLETED SEDIMENT FENCE IS AT LEAST 450mm, BUT NOT MORE THAN 700mm HIGH. IF A SPILL-THROUGH WEIR IS INSTALLED, ENSURE THE CREST OF THE WEIR IS AT LEAST 300mm ABOVE GROUND LEVEL.

14. BACKFILL THE TRENCH AND TAMP THE FILL TO FIRMLY ANCHOR THE BOTTOM OF THE FABRIC AND MESH TO PREVENT WATER FROM FLOWING UNDER THE FENCE.

ADDITIONAL REQUIREMENTS FOR THE INSTALLATION OF A SPILL-THROUGH WEIR

1. LOCATE THE SPILL-THROUGH WEIR SUCH THAT THE WEIR CREST WILL BE LOWER THAN THE GROUND LEVEL AT EACH END OF THE FENCE.

2. ENSURE THE CREST OF THE SPILL-THROUGH WEIR IS AT LEAST 300mm THE GROUND ELEVATION.

3. SECURELY TIE A HORIZONTAL CROSS MEMBER (WEIR) TO THE SUPPORT POSTS/ STAKES EACH SIDE OF THE WEIR. CUT THE FABRIC DOWN THE SIDE OF EACH POST AND FOLD THE FABRIC OVER THE CROSS MEMBER AND APPROPRIATELY SECURE THE FABRIC.

4. INSTALL A SUITABLE SPLASH PAD AND/OR CHUTE IMMEDIATELY DOWN-SLOPE OF THE SPILL-THROUGH WEIR TO CONTROL SOIL EROSION AND APPROPRIATELY DISCHARGE THE CONCENTRATED FLOW PASSING OVER THE WEIR.

MAINTENANCE

1. INSPECT THE SEDIMENT FENCE AT LEAST WEEKLY AND AFTER ANY SIGNIFICANT RAIN. MAKE NECESSARY REPAIRS IMMEDIATELY.

2. REPAIR ANY TORN SECTIONS WITH A CONTINUOUS PIECE OF FABRIC FROM POST TO POST.

3. WHEN MAKING REPAIRS, ALWAYS RESTORE THE SYSTEM TO ITS ORIGINAL CONFIGURATION UNLESS AN AMENDED LAYOUT IS REQUIRED OR SPECIFIED.

4. IF THE FENCE IS SAGGING BETWEEN STAKES, INSTALL ADDITIONAL SUPPORT POSTS.

5. REMOVE ACCUMULATED SEDIMENT IF THE SEDIMENT DEPOSIT EXCEEDS A DEPTH OF 1/3 THE HEIGHT OF THE FENCE.

6. DISPOSE OF SEDIMENT IN A SUITABLE MANNER THAT WILL NOT CAUSE AN EROSION OR POLLUTION HAZARD.

7. REPLACE THE FABRIC IF THE SERVICE LIFE OF THE EXISTING FABRIC EXCEEDS 6-MONTHS.

REMOVAL

1. WHEN DISTURBED AREAS UP-SLOPE OF THE SEDIMENT FENCE ARE SUFFICIENTLY STABILISED TO RESTRAIN EROSION, THE FENCE MUST BE REMOVED.

2. REMOVE MATERIALS AND COLLECTED SEDIMENT AND DISPOSE OF IN A SUITABLE MANNER THAT WILL NOT CAUSE AN EROSION OR POLLUTION HAZARD.

3. REHABILITATE/REVEGETATE THE DISTURBED GROUND AS NECESSARY TO MINIMISE THE EROSION HAZARD.

Drawn:	Date:		
GMW	May-10	Sediment Fence	ESC-05

Appendix D - Logan City Council Flood Report



Flood Report

During a flood or other emergency event, please visit Logan's [Disaster Dashboard](#) for the latest information.

This Flood Report provides information from Logan's planning scheme and any updated information Council has accepted from more recent flood studies.

Property Details

Address: 153-161 Beenleigh Redland Bay Road CORNUBIA QLD 4130
Lot/Plan: Lot 12 SP 114352 **Property Key:** 236907
Property Size: 2,678 m² (survey plan area) **Division:** 10
Zone and precinct: Low Density Residential - Small Lot

Flood hazard overlay in Logan Planning Scheme 2015	NO	This property is not mapped on the Flood hazard overlay map in the Logan Planning Scheme 2015. If more recent information about the flood hazard is available, it should be used to inform development decisions. This is to ensure risks associated with flood hazard are avoided or mitigated to protect people and property. See further details below.
Flood Level Information	NO	There is no flood level information for this property included in this report. This does not mean the property is not potentially impacted by floods. Please see further details below or contact Council's River and Catchment Engineering Program using the details in the Further Information section below.
Updated flood mapping based on more recent flood studies	NO	There is no updated flood mapping for this property at this time. This may change in future. Please contact Council's River and Catchment Engineering Program using the details in the Further Information section below or check this report in future.

Planning Scheme Flood hazard overlay map

The selected property is shown on the extract below of the Flood hazard overlay map in the Logan Planning Scheme 2015.

Various provisions of the [Logan Planning Scheme 2015](#) which refer to premises affected by the 'flood hazard overlay' apply to the part(s) of the property affected by the Flood hazard overlay map. The map may not reflect the most recent information about flood hazard.

If more recent information is available about the flood hazard for this property, that should be used to inform development decisions to ensure risks associated with flood hazard are avoided or mitigated to protect people and property. Please refer to the Updated flood mapping section below.

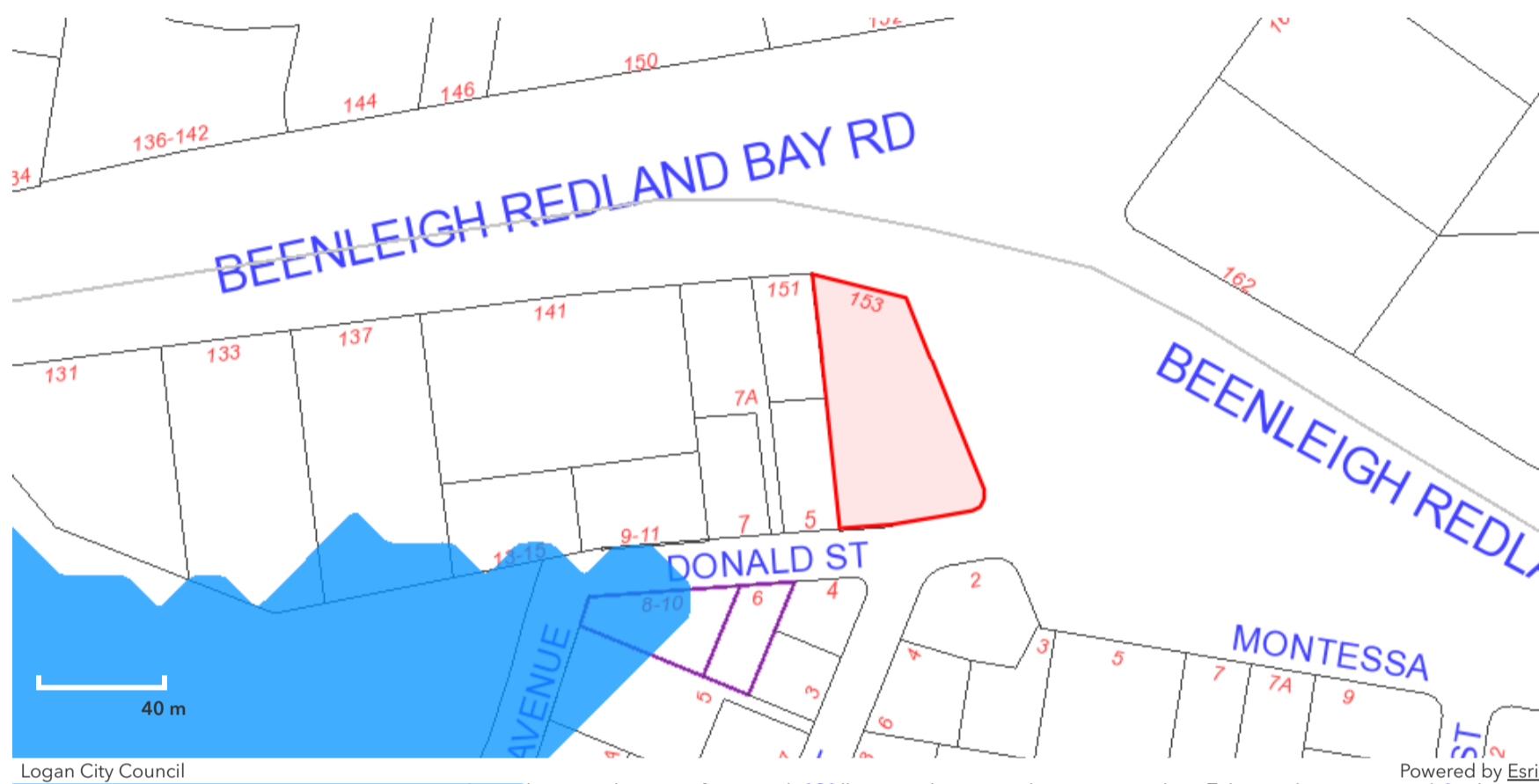

Further Information

Please refer to the [Flood Risk Fact Sheet](#) or contact Council using the details below.

Planning and development enquiries	Contact Council on 07 3412 5269 or email development@logan.qld.gov.au Before lodging a development application, pre-lodgement advice is recommended.
Building information	Contact Council on 07 3412 3412 or email council@logan.qld.gov.au . You can also contact a private building certifier .
Flood studies and modelling information	Contact Council on 07 3412 3412 or email council@logan.qld.gov.au . Flood studies are available from the Flood page on Council's website.
Properties in Priority Development areas	Contact Economic Development Queensland .

Please note:

1. This report can be used for the purposes of development assessment but should **not** be relied upon as part of a property transaction.
2. This report does not represent the highest possible flood level that might affect the property, as floods are highly unpredictable and variable.
3. A property may also be affected by other sources of potential inundation.
4. The flood levels are sourced from Council's accepted flood studies and flood modelling and are measured in metres Australian Height Datum (AHD), where mean sea level is approximately zero (0) metres AHD. Ground level information for the property is provided as context for the flood levels.
5. The flood mapping and levels in this report are based on data that was obtained through flood studies undertaken at a particular time and date and which are subject to change. For example, if the method for calculating flood levels is updated, industry guidelines are amended, or more recent information becomes available, this may result in changes to the information in this report.
6. If flood level information is not available (shown as 'N/A'), you will need to contact Council using the details in the table above.
7. This report provides limited information for development assessment purposes and is not a substitute for independent professional advice. You should engage the services of a Registered Professional Engineer of Queensland (RPEQ) to obtain site specific information regarding the flood risk to your property and any the implications for any proposed building or development.
8. Although Logan City Council takes reasonable care in producing this report, it does not guarantee the information is accurate, complete, or current. Logan City Council does not accept any responsibility for any loss or damage (however it was caused) in connection with the use of or reliance on the information in this report.

Logan City Council

PO Box 3226 Logan Central QLD 4114

Generated: Friday, 10 March 2023 3:14 PM**Phone:** (07) 3412 5269**Email:** council@logan.qld.gov.au**Web:** logan.qld.gov.au

Appendix E - Logan City Council Development Codes



153-161 Beenleigh Redland Bay Road, Cornubia QLD 4130

LCC Filling and Excavation Code

Filling and Excavation Code

9.4.2.3 Criteria for assessment

Part A—Criteria for self-assessable and assessable development

Table 9.4.2.3.1—Filling and excavation code: self-assessable and assessable development

Performance outcomes	Acceptable outcomes	Response
Protection of natural processes and ecosystems		
PO1 The discharge of sediments and pollutants from filling or excavation does not adversely affect a waterway or the stormwater network.	AO1 The discharge of sediments and pollutants to a waterway or stormwater network complies with part 3.3—Filling and excavation standards in planning scheme policy 5—infrastructure.	Filling and excavation will be carried out in accordance with planning scheme policy 5 and the erosion and sediment control plan to ensure sediments and pollutants from filling or excavation do not adversely affect waterways or the stormwater network.
PO2 Topsoil and spoil stockpiled on the premises do not adversely affect natural processes and ecosystems.	AO2 Topsoil and spoil is stockpiled to comply with part 3.3—Filling and excavation standards in planning scheme policy 5—Infrastructure.	Topsoil and spoil will be stockpiled and contained in accordance with Planning Scheme Policy 5 to ensure there are no adverse effects on natural processes and ecosystems.
PO3 Filling is carried out using stable, solid and clean earth, free of organic and putrescible waste, rubbish and refuse material.	AO3 Filling complies with part 3.3—Filling and excavation standards in planning scheme policy 5—Infrastructure.	Fill material used will be stable, solid, and clean earth free of organic and putrescible waste, rubbish and refuse material.
Protection of existing and planned infrastructure		
PO4 Filling or excavation works do not adversely affect infrastructure, including any services.	AO4 Filling or excavation works comply with part 3.3— Filling and excavation standards in planning scheme policy 5—Infrastructure.	Filling and excavation on site will be designed and completed such that works do not adversely affect infrastructure, including any services.
Protection and enhancement of personal health and safety and premises		
PO5 Filling or excavation works do not adversely affect personal health and safety.	AO5	Proposed filling an excavation on site will not adversely affect personal health and safety.

153-161 Beenleigh Redland Bay Road, Cornubia QLD 4130

LCC Filling and Excavation Code

Performance outcomes	Acceptable outcomes	Response
	Filling or excavation works comply with part 3.3– Filling and excavation standards in planning scheme policy 5–Infrastructure.	
Surface water flow		
<p>PO6 Surface water drainage does not cause any of the following:</p> <ul style="list-style-type: none"> a) Ponding on any premises; or b) A hazard or adversely affect personal health and safety and premises; or c) Diversion or concentration of flow from or onto adjoining premises or infrastructure. 	<p>AO6 Surface water drainage complies with part 3.3– Filling or excavation standards in planning scheme policy 5–Infrastructure.</p>	Any proposed cut or fill on the site will not cause ponding, safety hazard or diversion or concentration of flow onto adjoining properties. Surface water drainage will comply with Planning Scheme Policy 5.
Batters		
<p>PO7 A batter:</p> <ul style="list-style-type: none"> a) Does not adversely affect the natural physical processes and ecosystems; b) Protects existing and planned infrastructure; c) Is safe, stable and easily maintained; d) Is landscaped to enhance visual amenity. 	<p>AO7 A batter is designed and constructed to comply with the standards specified in section 3.3.6– Batters and retaining walls in planning scheme policy 5–Infrastructure.</p>	All proposed batters will be designed and constructed in accordance with Planning Scheme, Policy 5.
Retaining Walls		
<p>PO8 A retaining wall:</p> <ul style="list-style-type: none"> a) Is not constructed of timber and are not located on existing or proposed lot boundaries, or movement networks; b) Does not adversely affect the natural physical processes and ecosystems; 	<p>AO8 A retaining wall is designed and constructed to comply with the standards specified in section 3.3.6.2–Retaining walls in planning scheme policy 5–Infrastructure.</p>	All proposed retaining walls will be designed and constructed in accordance with Planning Scheme Policy 5.

153-161 Beenleigh Redland Bay Road, Cornubia QLD 4130

LCC Filling and Excavation Code

Performance outcomes	Acceptable outcomes	Response
<ul style="list-style-type: none"> c) Is located to avoid conflict with adjoining premises; d) Is located such that existing and planned infrastructure is not adversely affected; e) Protects the visual amenity of adjoining premises or a public open space; f) Is located within the premises that is being filled; g) Is located within the premises that is cut and is designed to take any surcharge loading allowable on the uphill lot; h) Is safe and stable; i) Enables easy access for maintenance. 		
Filling of a dam		
<p>PO9 The filling of a dam:</p> <ul style="list-style-type: none"> a) Does not adversely affect the natural physical processes and ecosystems; b) Creates a safe and stable surface; c) Is integrated into the landscape. 	<p>AO9 The filling of a dam complies with part 3.3–Filling and excavation standards in planning scheme policy 5–Infrastructure.</p>	<p>Not applicable to this development</p>

153-161 Beenleigh Redland Bay Road, Cornubia QLD 4130

LCC Infrastructure Code

Infrastructure Code

9.4.3.3 Criteria for assessment

Part A–Criteria for self-assessable and assessable development

Table 9.4.3.3.1–Infrastructure code: self-assessable and assessable development

Performance outcomes	Acceptable outcomes	Response
Provision, design, construction and location of infrastructure		
<p>PO1</p> <p>Development is demonstrated to be capable of being serviced by necessary infrastructure.</p>	<p>AO1</p> <p>Reports, plans and drawings are provided in accordance with part 2 of planning scheme policy 5–Infrastructure.</p>	<p>Development will be serviced by necessary infrastructure as shown on the design drawings attached in the SBSMP report.</p>
<p>PO2</p> <p>Development:</p> <p>a) provides necessary infrastructure to service the development;</p> <p>b) provides that the design, construction and location of necessary infrastructure:</p> <ol style="list-style-type: none"> protects existing and planned infrastructure networks; services proposed development; integrates with existing and planned infrastructure networks; delivers a standard of service that is efficient and equitable; minimises the cost to the community for the life of the infrastructure by providing a suitable design life, ease of maintenance and ease of replacement; protects personal health, safety and premises; protects environmental values. 	<p>AO2</p> <p>Development:</p> <p>a) in a water supply service area connects to the water network in accordance with the SEQ Water Supply and Sewerage Design and Construction Code;</p> <p>b) not in a water supply service area provides a tank with a minimum storage capacity of 45,000 litres;</p> <p>c) in a sewerage supply service area connects to the waste water network in accordance with the SEQ Water Supply and Sewerage Design and Construction Code;</p> <p>d) not in a sewerage supply service area complies with part 1 of the Queensland Plumbing and Wastewater Code;</p> <p>e) provides stormwater infrastructure in accordance with part 3.6 of planning scheme policy 5–Infrastructure;</p> <p>f) provides a movement network infrastructure in accordance with part 3.4 of planning scheme policy 5–Infrastructure;</p> <p>g) provides parks in accordance with part 3.12 of planning scheme policy 5–Infrastructure;</p> <p>h) provides road lighting in accordance with part 3.5 of planning scheme policy 5– Infrastructure;</p> <p>i) provides electricity reticulation in accordance with part 3.8 of planning scheme policy 5–Infrastructure;</p>	<p>Development:</p> <p>a) connects to the water network in accordance with the SEQ Water Supply and Sewerage Design and Construction Code.</p> <p>b) not applicable</p> <p>c) not applicable</p> <p>d) not applicable</p> <p>e) provides stormwater infrastructure in accordance with part 3.6 of planning scheme policy 5–Infrastructure;</p> <p>f) provides a movement network infrastructure in accordance with part 3.4 of planning scheme policy 5–Infrastructure</p> <p>g) not applicables</p> <p>h) provides road lighting in accordance with part 3.5 of planning scheme policy 5–Infrastructure;</p> <p>i) provides electricity reticulation in accordance with part 3.8 of planning scheme policy 5–Infrastructure;</p> <p>j) provides gas and telecommunications reticulation in accordance with part 3.9 of planning scheme policy 5–Infrastructure.</p> <p>k) Proposed development is consistent with the general planning layouts in part 7.2 of the</p>

153-161 Beenleigh Redland Bay Road, Cornubia QLD 4130

LCC Infrastructure Code

Performance outcomes	Acceptable outcomes	Response
	<p>j) provides gas and telecommunications reticulation in accordance with part 3.9 of planning scheme policy 5—Infrastructure.</p> <p>k) is consistent with the general planning layouts in part 7.2 of Planning scheme policy 5 - Infrastructure.</p> <p>Editor's note - The delivery of any part of a network identified in the plans for trunk infrastructure is governed by Part 4 - Local government infrastructure plan.</p>	<p>Planning scheme policy 5 – Infrastructure, where it is applicable.</p>
Location of development		
<p>PO3</p> <p>Development is located to protect existing and planned infrastructure networks.</p>	<p>A03</p> <p>Development is located outside:</p> <p>a) planned widening of a road or a new road identified in Table 7.3.1.1—Road encroachment maps of planning scheme policy 5—Infrastructure;</p> <p>b) planned public transport network identified on Figure 3.4.1.3.1—Public transport network in planning scheme policy 5— Infrastructure;</p> <p>c) a planned cycle network identified on Figure 3.4.1.2.1—Cycle network in planning scheme policy 5—Infrastructure;</p> <p>d) a planned park network identified in PIP map 09.00 Plan for trunk park infrastructure in Schedule 3—Priority infrastructure plans and mapping.</p>	<p>Development is located to protect existing and planned infrastructure network.</p>
Fire fighting		
<p>PO4</p> <p>Development in a water service area accessed by common private title provides:</p> <p>a) fire hydrant infrastructure;</p> <p>b) unimpeded access for emergency services vehicles.</p> <p>Editor's note - The term common private title refers to areas such as access roads in community title developments or strata title unit access, which are private and under group or body corporate control.</p>	<p>A04</p> <p>Development in a water service area involving a material change of use or reconfiguring a lot where, or to be, accessed by common private title ensures that fire hydrant placement and technical requirements for streets and access ways are in accordance with:</p> <p>a) Australian Standard (AS) 2419.1 - 2005 Fire hydrant installations;</p> <p>b) QFES: Fire Hydrant and vehicle access guidelines for residential, commercial and industrial lots.</p>	<p>Development provides necessary fire hydrant infrastructure and unimpeded access for emergency services vehicles.</p>

153-161 Beenleigh Redland Bay Road, Cornubia QLD 4130

LCC Infrastructure Code

Performance outcomes	Acceptable outcomes	Response
<p>PO5</p> <p>Development not in a water service area provides sufficient water storage with adequate pressure, volume and flow to service development for firefighting purposes.</p>	<p>AO5</p> <p>Development:</p> <ul style="list-style-type: none"> a) Is connected to a reticulated water supply scheme that has sufficient flow and pressure characteristics for firefighting purposes at all times with a minimum pressure and flow of 10 liters per second at 200kPa; or b) has an on-site water storage in accordance with Table 9.4.3.3.2—Water storage for firefighting, dedicated or retained for firefighting purposes that is made of fire resistant materials and is: <ul style="list-style-type: none"> i. a separate tank; or ii. a reserve section in the bottom part of the main water supply tank water tank. <p>Editor's note - The requirement in AO5 is: - in addition to the requirement for potable water supply/storage in AO2 in Table 9.4.3.3.1 - Infrastructure code: accepted development (subject to requirements) and assessable development; - reflected in AO5 in Table 8.2.3.3.1 - Bushfire hazard overlay code: accepted development (subject to requirements) and assessable development.</p>	<p>Refer to SBSMP regarding development's water service.</p>
<p>Disposal of trade waste</p>		
<p>PO6</p> <p>The disposal of trade waste in a sewerage supply service area does not adversely affect the sewerage network.</p>	<p>AO6</p> <p>The disposal of trade waste in a sewerage supply service area complies with the sewer admission standards in section 3.2.6—Sewer admission standards in planning scheme policy 3—Environmental management.</p>	<p>Refer to SBSMP regarding development's sewer service.</p>

153-161 Beenleigh Redland Bay Road, Cornubia QLD 4130

LCC Infrastructure Code

Performance outcomes	Acceptable outcomes	Response
Roof water drainage and surface water drainage		
<p>PO7</p> <p>Development provides stormwater infrastructure for the drainage of the premises so as not to cause any of the following:</p> <ul style="list-style-type: none"> a) ponding of stormwater on the premises; b) a hazard to personal health and safety; c) damage to premises; d) an increased risk of flooding to premises within the catchment. 	<p>AO7</p> <p>Development complies with the standards for stormwater infrastructure specified in part 3.6 of planning scheme policy 5–Infrastructure.</p>	<p>Proposed stormwater infrastructure will not cause any adverse hydraulic impacts or actionable nuisance to surrounding properties nor will it create a health and safety hazard.</p>
Natural flow of surface water		
<p>PO8</p> <p>Development provides that the natural flow of surface water is:</p> <ul style="list-style-type: none"> a) not altered so as to cause a risk to personal health and safety or damage to property; b) not increased in intensity, velocity or frequency; c) not concentrated onto adjoining premises. 	<p>AO8</p> <p>Development complies with the standards for stormwater infrastructure specified in part 3.6 of planning scheme policy 5–Infrastructure.</p>	<p>Development will not affect the natural flow of surface water so as to cause a risk to personal health and safety or damage to property nor an increase in intensity, velocity or frequency. The development will not cause surface water to be concentrated onto adjoining properties.</p>

153-161 Beenleigh Redland Bay Road, Cornubia QLD 4130

LCC Infrastructure Code

Performance outcomes	Acceptable outcomes	Response
Water sensitive urban design		
<p>PO9</p> <p>Development which provides stormwater infrastructure incorporates water sensitive urban design principles having regard to:</p> <ul style="list-style-type: none"> a) protecting existing natural features and ecological processes; b) protecting the natural hydrologic behavior of catchments; c) protecting the existing natural flow and water quality regimes of waterways; d) protecting water quality of surface and ground waters; e) minimising demand on the water network; f) minimising sewage discharges to the natural environment; g) integrating water into the landscape to enhance visual and ecological values. 	<p>AO9</p> <p>Development complies with the standards for stormwater infrastructure specified in part 3.6 of planning scheme policy 5—Infrastructure.</p>	<p>Development incorporates water sensitive urban design principles and complies with the standards for stormwater infrastructure specified in part 3.6 of planning scheme policy 5—Infrastructure.</p>
Movement network		
<p>PO10</p> <p>The projected traffic levels for a use do not adversely affect the planned standards of service for a road or intersection.</p>	<p>AO10</p> <p>Development does not cause or contribute to projected traffic levels:</p> <ul style="list-style-type: none"> a) exceeding the maximum vehicle trips per day in Table 3.4.1.4.2 in planning scheme policy 5—Infrastructure; or b) exceeding the maximum control delays through intersections in peak periods in Table 3.4.1.4.3 in planning scheme policy 5—Infrastructure. 	<p>The projected traffic levels for the development will not adversely affect the planned standards of service in the area of the development.</p>
Integrated movement concept report		
<p>PO11</p> <p>Development which generates more than 3,000 vehicle trips per average weekday is designed to integrate the movement network to minimize the transportation costs required to service the use.</p>	<p>AO11</p> <p>Development which generates more than 3,000 vehicle trips per average weekday provides an integrated movement concept report which integrates the planning of the movement network in accordance with part 2 and 3 of planning scheme policy 5—Infrastructure.</p>	<p>Not applicable to this development.</p>

153-161 Beenleigh Redland Bay Road, Cornubia QLD 4130

LCC Infrastructure Code

Performance outcomes	Acceptable outcomes	Response
Land use and transport integration		
<p>PO12</p> <p>Development within 400 metres of existing or future public passenger transport facilities where the total site area is 5,000m² or more:</p> <ul style="list-style-type: none">a) supports a road hierarchy which facilitates efficient, safe and accessible bus services connecting to existing and future public passenger transport facilities;b) enhances connectivity between existing and future public passenger transport facilities and other transport modes;c) optimizes the walkable catchment to existing and future public passenger transport facilities;d) provides for direct and safe access to and use of existing or future public passenger transport facilities. <p>Note – SPP code: Land use and transport integration in Appendix 4 of the state planning policy provides guidance to achieve this outcome.</p>	<p>AO11</p> <p>No acceptable outcome provided.</p>	<p>Not applicable to this development.</p>

Appendix F - SPEL Filter Operation and Maintenance Manual



SPEL Stormsack

At Source Gross Pollutant Trap



spelstormwater
joy in water

spel.com.au

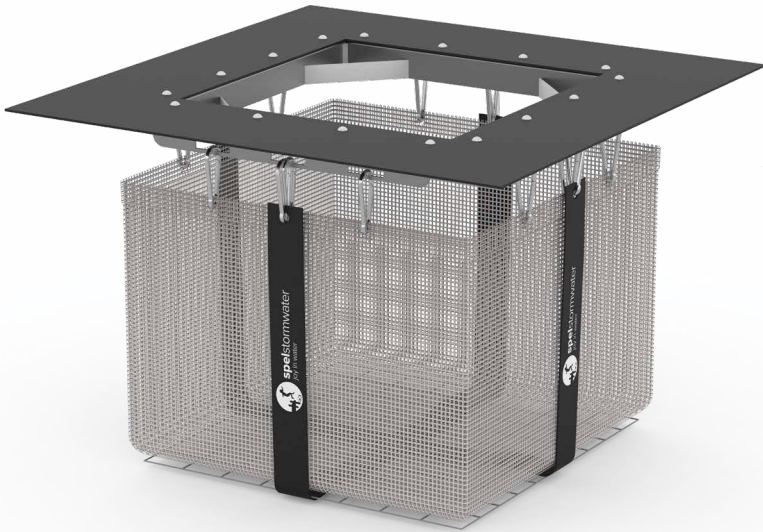

APPLICATIONS

- Council storm drain retrofits
- Commercial / retail / residential
- Litter prone urban areas
- Scrap metal / solid waste / oil storage
- Part of treatment train
- Construction sediment / erosion



BENEFITS

- Can be modelled in MUSIC in conjunction with bio-retention
- Low cost gross pollutant capture
- Quick & easy installation
- Simple maintenance
- At source capture
- Adjusts to custom pit sizes

The SPEL Stormsack is specifically designed for the capture of gross pollutants: sediment, litter, and oil and grease. Ideally suited for storm drain retrofits, the SPEL Stormsack's unique design allows maintenance to be performed using conventional vacuum suction equipment.

SPEL Stormsack filtration solutions are highly engineered water quality devices that are deployed directly in the stormwater system to capture contaminants close the surface for ease of maintenance. Easily retrofitted into new or existing structures, SPEL Stormsack filtration technology is a decentralized approach to stormwater treatment that essentially repurposes traditional site infrastructure and customizes it to meet specific site water quality goals. In this way, it satisfies important objectives of today's LID (Low Impact Development) criteria.

From an operations perspective, catch basins with SPEL Stormsack filters are also easier and quicker to clean out because pollutants are trapped just under the grate.

The SPEL Stormsack was introduced to the Australian market in 2012 and field testing is underway at several locations in South-east Queensland. Laboratory testing has shown capture of 99.99% of gross pollutants up to the bypass flow rate.* Further results will be provided as they become available.

Recommended minimum clearance from bottom of SPEL Stormsack to inside bottom of vault is 50mm. Typical frame adjustability range of 127mm in each direction.

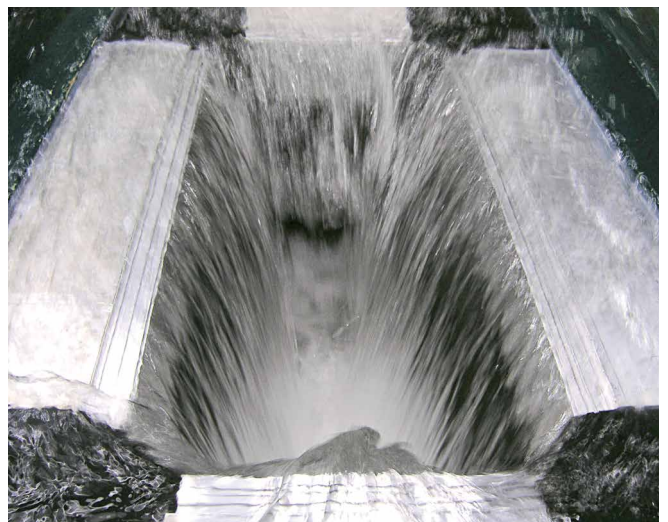

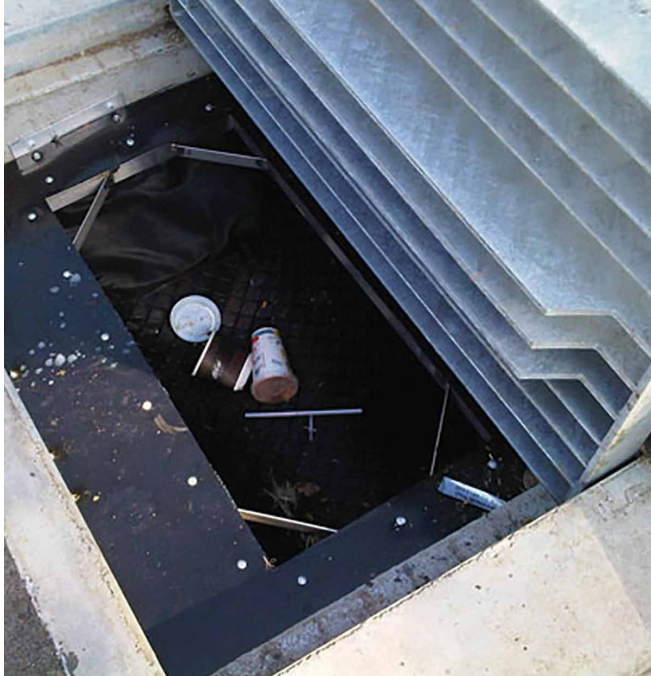

HOW IT WORKS

This technology is a post developed stormwater treatment system. The SPEL Stormsack provides effective filtration of solid pollutants and debris typical of urban runoff, while utilising the existing or new storm drain infrastructure. The Stormsack is designed to rest on the flanges of conventional catch basin frames and is engineered for most hydraulic and cold climate conditions.

Installation procedures shall include removing the storm grate, cleaning the ledge of debris and solids, measuring catch basin clear opening and adjusting flanges to rest on grate support ledge. Install SPEL Stormsack with splash guard under curb opening so the adjustable flanges are resting on the grate support ledge. Install corner filler pieces. Reinstall storm grate directly on support flanges rise shall be no more than 3mm.

Maintenance: Typically the SPEL Stormsack is serviceable from the street level, and therefore maintenance does not require confined space entry into the catch basin structure. The unit is designed to be maintained in place with a vacuum hose attached to a sweeper or a vactor truck. Use only SPEL replaceable parts.

FEATURES

Pollutant	Efficiency
Gross Pollutants (GP)	100%
Total Suspended Solids (TSS)	61%
Total Phosphorus (TP)	28%
Total Nitrogen (TN)	45%

*Contact Spel to confirm approved performance for the project LGA

Application	Regulatory Issue	Target Pollutants
Council Storm Drain Retrofits	At-source litter capture	Sediment, Litter, O&G
Commercial/Retail/Residential	Stormwater Compliance	Sediment, Litter, O&G
Litter Prone Urban Areas	Cost effective litter control	Litter \geq 5 mm
Scrap Metal/Solid Waste/Oil Storage/Etc	Industrial Multi-Sector General Permit	Gross Pollutants, O&G
Part of Treatment Train	Council Stormwater Quality Improvement Targets	Sediment, Litter, O&G
Construction Sediment/Erosion	Sediment Control Plan	Sediment/Erosion Control

Features	
1.	1. Ultra-Durable Aluminium Frame <ul style="list-style-type: none"> Available in 450x450mm, 600x600mm, 600x900mm and 900x900mm sizes Custom pit arrangements upon request
2.	Black Poly Surround riveted to Frame <ul style="list-style-type: none"> Can be cut to suit on site
3.	Reinforced Stormsack Bag <ul style="list-style-type: none"> Bag has sewed eyelets Square bottom design for even distribution
4.	Karabiners attach Bag to Frame for easy service & replacement
5.	Aluminium Support Angles & Fixings

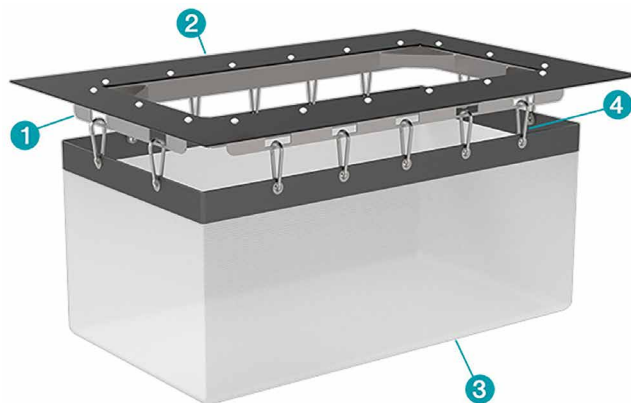

Standard SPEL Stormsack to suit Pit Sizes
450x450mm
600x600mm
900x600mm
900x900mm

Custom sizes (i.e. 1200x900mm) can be manufactured on short lead times

TECHNICAL DRAWINGS

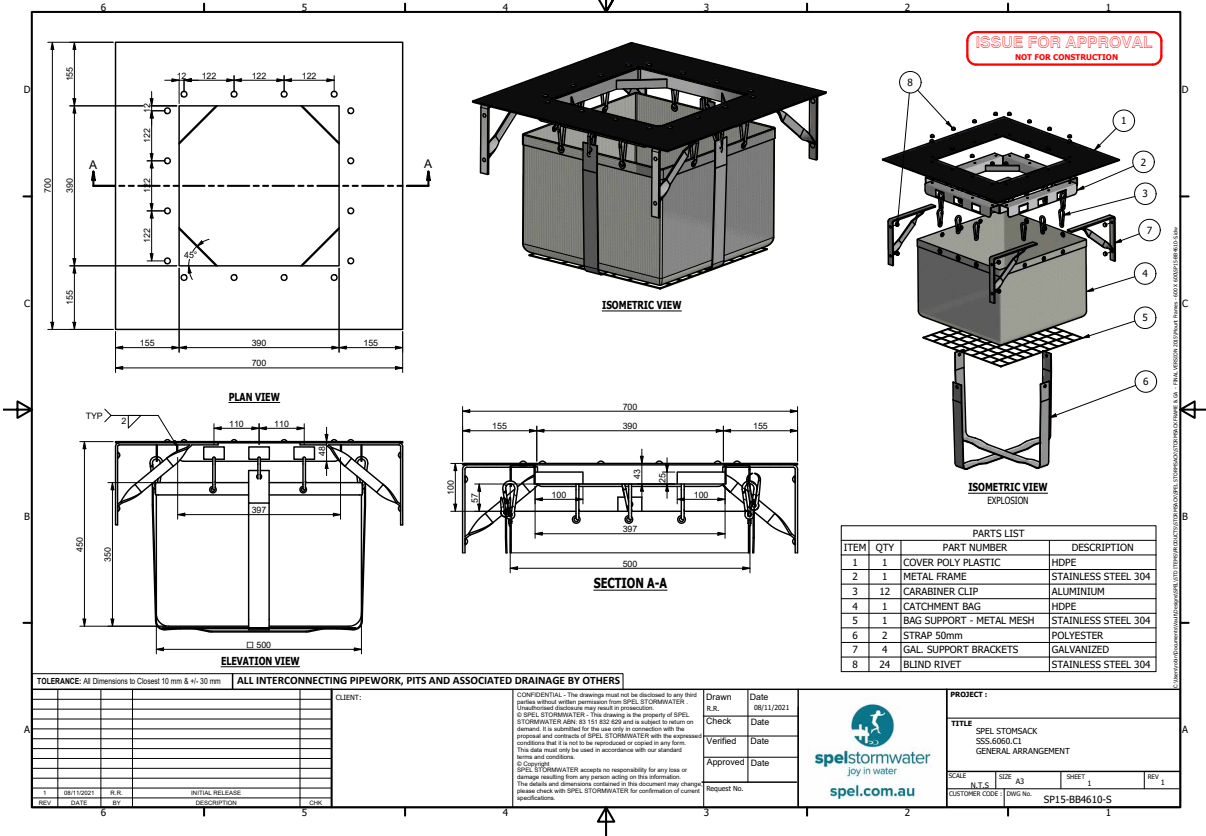
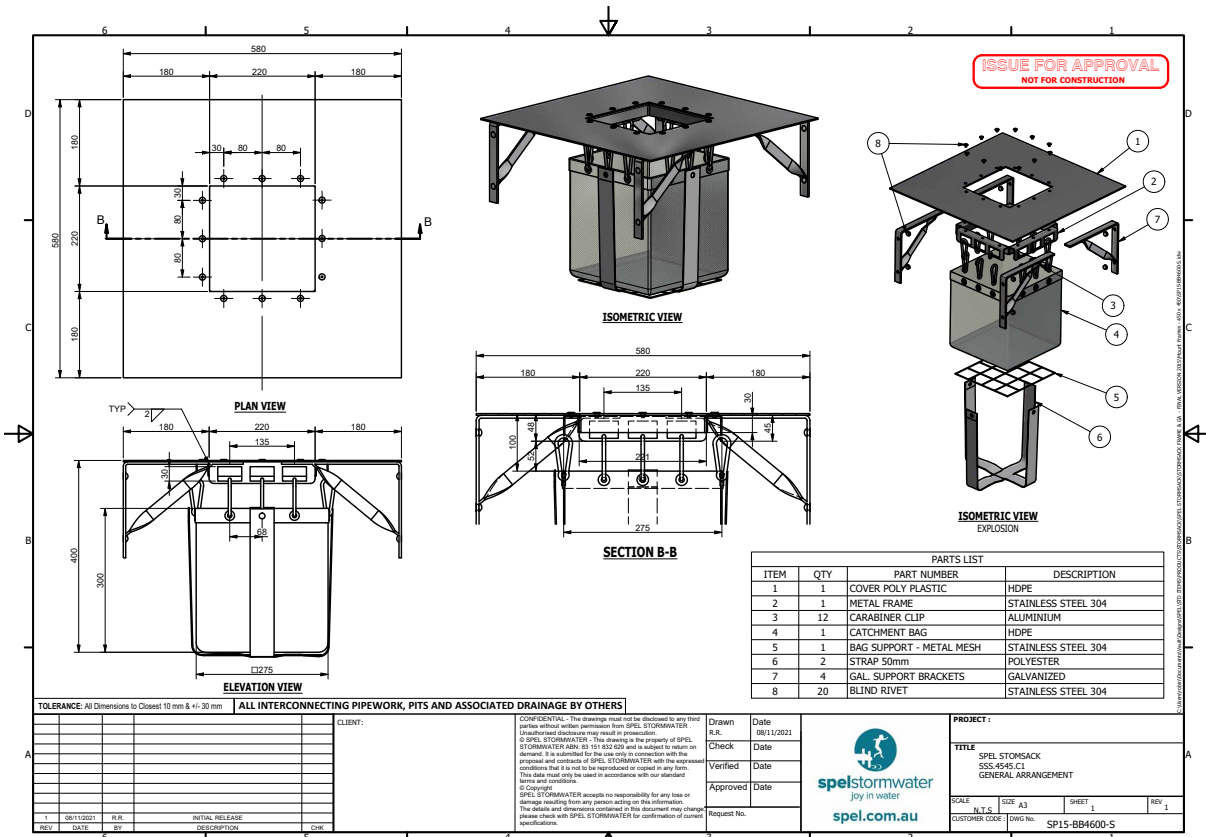

TECHNICAL DRAWINGS

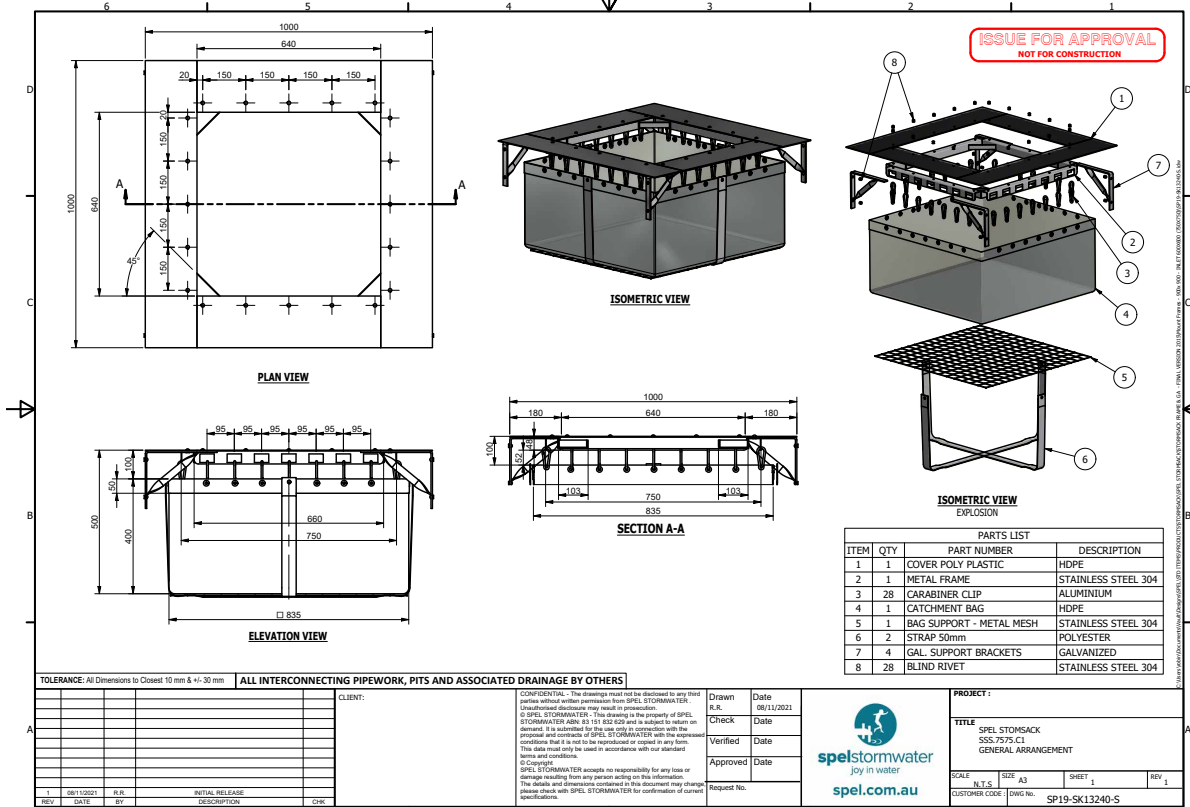
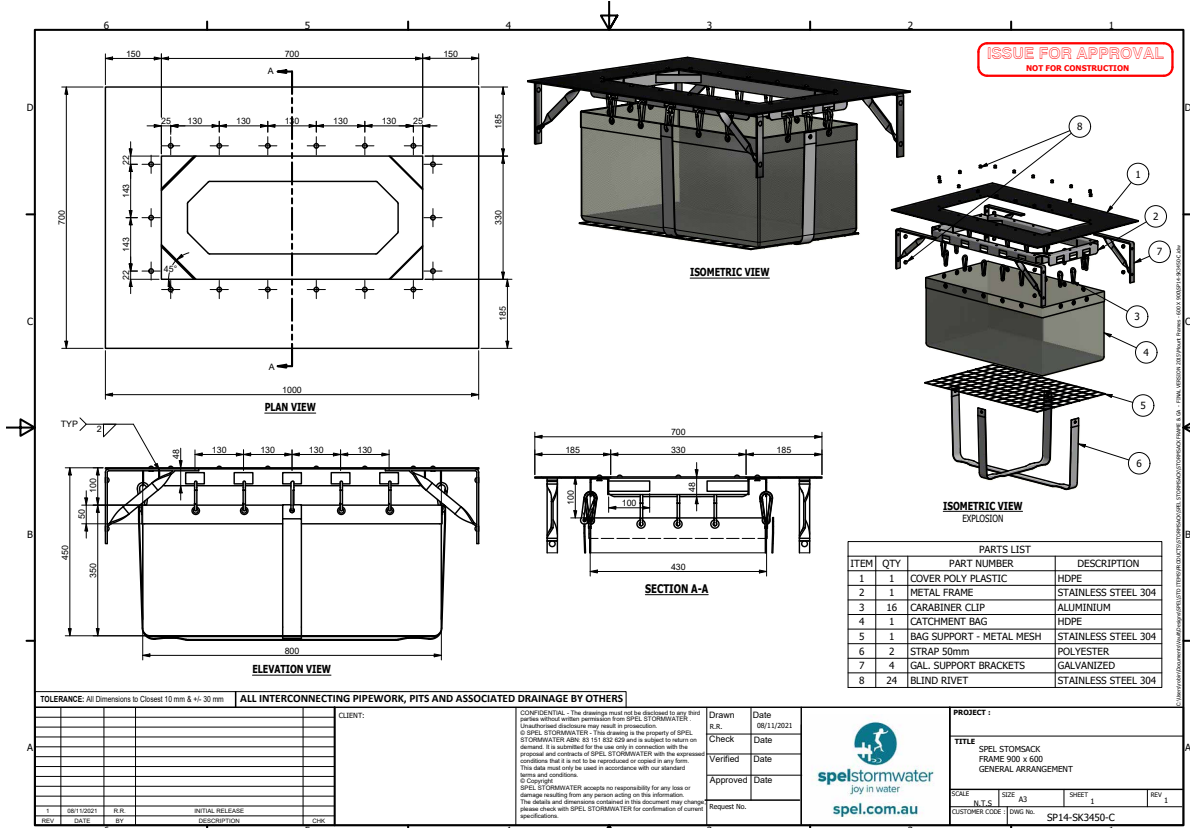

INSTALLATION DETAILS

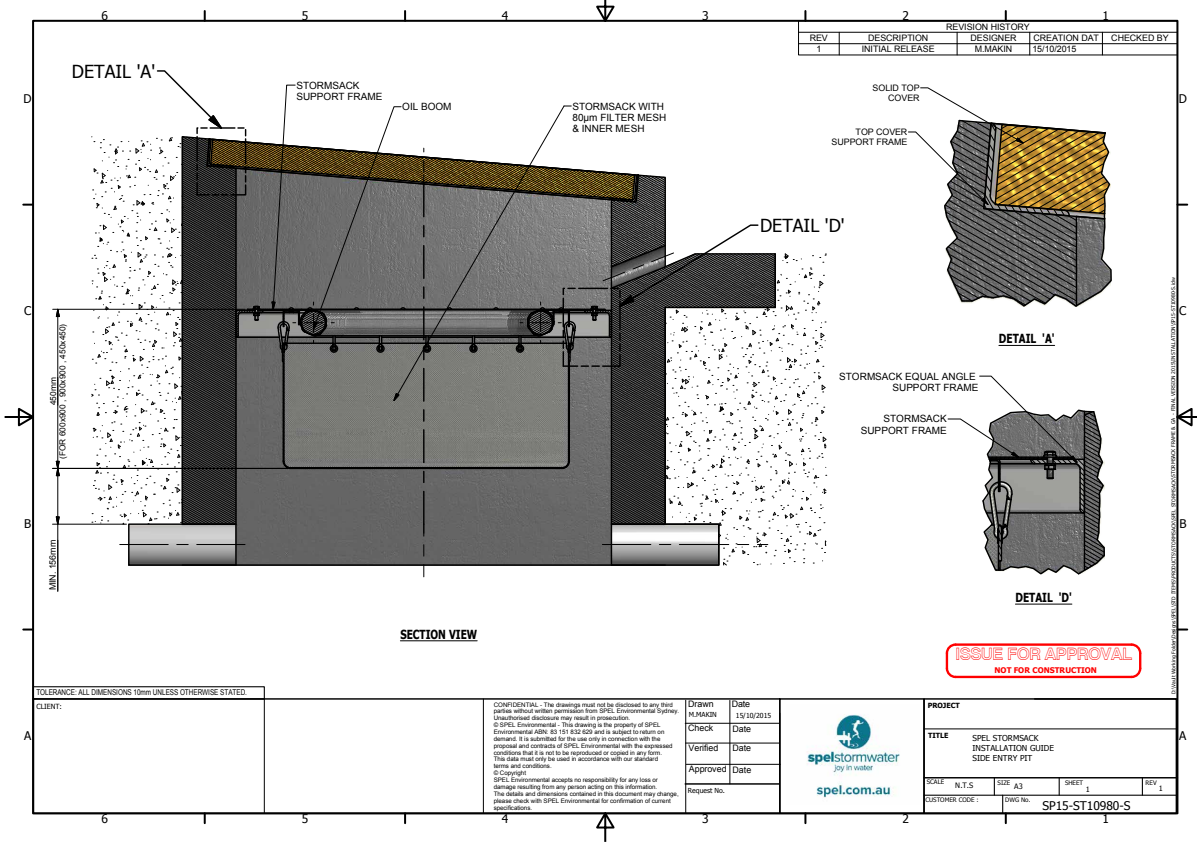
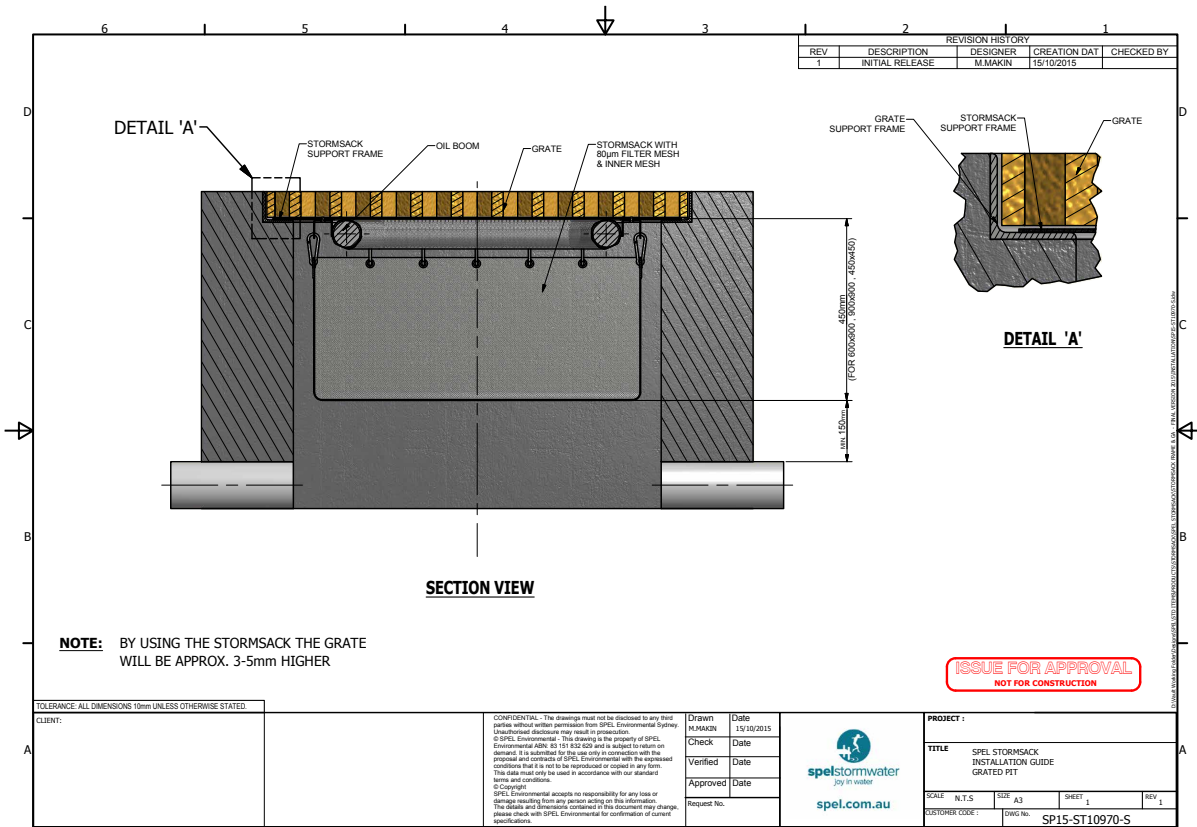

SPEL Stormsack

At Source Gross Pollutant Trap

<p>NSW HEAD OFFICE 100 Silverwater Rd, Silverwater NSW 2128 PO Box 7138, Silverwater NSW 1811 P: +61 2 8705 0255 P: 1300 773 500 E: nsw.sales@spel.com.au</p>	<p>QLD MAIN OFFICE 130 Sandstone Pl, Parkinson QLD 4115 P: +61 7 3271 6960 P: 1300 773 500 E: qld.sales@spel.com.au</p> <p>QLD SUNSHINE COAST BRANCH 19-27 Fred Chaplin Circuit, Bells Creek, QLD 4551 P: 1300 773 500 E: qld.sales@spel.com.au</p>	<p>VIC & TAS OFFICE 897 Wellington Rd Rowville VIC 3178 P: +61 3 5274 1336 P: 1800 810 139 E: sales@spel.com.au</p> <p>VIC GEELONG BRANCH 70 Technology Close, Corio, P: +61 3 5274 1336 P: 1800 810 139 E: sales@spel.com.au</p>
<p>SA OFFICE 9 Hampden Road, Mount Barker SA 5251 P: 1300 773 500 E: sales@spel.com.au</p>	<p>WA OFFICE 2 Modal Crescent Canning Vale WA 6155 P: +61 8 9350 1000 P: 1800 335 550 E: sales@spel.com.au</p>	<p>NZ OFFICE AUCKLAND 100 Montgomerie Road Airport Oaks P: +64 9 276 9045 E: sales@spel.com.au</p>
<p>NZ OFFICE WANGANUI 43 Heads Road Wanganu New Zealand P: +64 6 349 0088 E: sales@spel.com.au</p>	<p>NZ OFFICE WELLINGTON 41 Raiha St Porirua Wellington New Zealand P: +64 4 239 6006 E: sales@spel.com.au</p>	<p>PHILIPPINES OFFICE METRO MANILA Unit 2210 Lumiere Residences Pasig Boulevard, Pasig City P: +61 2 8705 0255 P: 1300 773 500 E: sales@spel.com.au</p>
<p>SINGAPORE OFFICE 512 Chai Chee Lane, #06-04 Bedok Industrial Estate, Singapore 469028 P: +61 2 8705 0255 P: 1300 773 500 E: sales@spel.com.au</p>	<p>UK OFFICE UNITED KINGDOM Lancaster Rd Shrewsbury SY1 3NQ UK P: +44 (0)1743 445200 E: sales@spel.com.au</p>	<p>USA OFFICE CLEVELAND 4548 Industrial Parkway Cleveland, Ohio 44135 P: +61 2 8705 0255 P: 1300 773 500 E: sales@spel.com.au</p>

We believe clean water is a right not a privilege and we work to ensure a joy in water experience for you with your children and grandchildren.

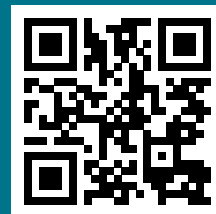

spelstormwater
joy in water

100 Silverwater Rd, Silverwater NSW 2128 Australia

Phone: (02) 8705 0255

Email: sales@spel.com.au

[spel.com.au](https://www.spel.com.au)

SPEL Stormwater accepts no responsibility for any loss or damage resulting from any person acting on this information. The details and dimensions contained in this document may change, please check with SPEL Stormwater for confirmation of current specifications.



Model Number

Job Number

StormSack[®] installation manual

www.spel.com.au

Purpose

The purpose of this manual is to indicate the safest and most efficient method in installing the SPEL StormSack

Personal protective equipment

The following personal protective equipment is required by staff for install activities:

- High visibility vest or shirt
- Safety footwear (Steel cap toe)
- Gloves (leather palmed riggers gloves or similar)

Note: Personnel on construction and private sites must also adhere to the specific safety requirements of each work site

Tools required for installation

- Tape measure
- Marker pen/texta
- Gloves
- Safety glasses
- Hearing protection
- Level/straight edge
- Grinder

Pre-Installation works (To be completed by others)

1. Inlet pits shall be clean prior to installation by either a "sucker truck" or manual methods
2. All solidified material and debris within the inlet pit shall be broken-out and removed.
3. Cleaning shall be carried out up to 1 week immediately prior to installation
4. Any standing water shall be removed from the inlet pit
5. Any pipe penetrations within the inlet pit must cut off flush with pit walls and rendered prior to installation

Installation

The aim of all StormSack installations is to install the largest unit into each pit, without influencing the hydraulic performance of the pit or drainage system. To provide clarification on certain aspects of the installation the following tolerances are included

1) Tools Required

- Tape measure
- Marker pen/texta
- Gloves
- Safety glasses
- Hearing protection
- Level/straight edge
- Grinder



2) Set up safety cones around pit before opening



3) Remove grates from pit ready for StormSack installation



4) Measure length & width of grate support ledge for StormSack to sit on



5) Use measuring tape and marker to mark plastic StormSack support sheet to be cut off



6) Use level/straight edge to mark a straight cutting line



7) Use angle grinder with cutting blade or similar to cut plastic StormSack support sheeting to match opening size



8) Once the plastic StormSack support sheet has been trimmed to suit grate opening simply install into grate support ledge



9) Re-install grates





HEAD OFFICE

PO Box 6144
Silverwater NSW 1811

100 Silverwater Rd
Silverwater NSW 2128

Phone: +61 2 8705 0255

Fax: +61 2 8014 8699



DESIGN OFFICES

New South Wales 61 2 8705 0255

Canberra 61 2 6128 1000

Queensland 61 7 3271 6960

Victoria & Tasmania 61 3 5274 1336

South Australia 61 8 8275 8000

West Australia 61 8 9350 1000

Northern Territory 61 2 8705 0255

New Zealand 64 9 276 9045



www.spel.com.au

SPEL Environmental accepts no responsibility for any loss or damage resulting from any person acting on this information. The details and dimensions contained in this document may change, please check with SPEL Environmental for confirmation of current specifications.



Model Number

Job Number

SPEL StormSack

OPERATIONS & MAINTENANCE

www.spel.com.au

Manual Introduction

Maintenance of the SPEL StormSack is essential to preservation of its condition to ensure lifetime operational effectiveness.

The SPEL StormSack is a highly engineered water quality device that is deployed directly in the stormwater system as primary treatment to capture contaminants close to the surface. To ensure full operational capacity, it is vital to ensure that the pollutants it captures are periodically removed, and filtration components are thoroughly cleaned.

Maintenance frequencies and requirements of the SPEL StormSack are dependent on the biological factors of the site in which it is situated. These factors can include excessive sediment loading or occurrence of toxic chemicals due to the natural and unnatural factors such as site erosion, chemical spills or extreme storms.

This manual has been designed by the SPEL StormSack Manufacturer the client or device owner in the maintenance of the SPEL StormSacks.

This manual should be used in conjunction with the relevant site traffic management and safety plans, as well as any other provided documentation from SPEL.

SPEL StormSack Specifications/Features

CHAPTER 2

1. General Description

The SPEL StormSack provides effective filtration of solid pollutants and debris typical of urban runoff, while utilising the existing or new storm drain infrastructure. The StormSack is designed to rest on the flanges of conventional catch basin frames and is engineered for most hydraulic and cold climate conditions.

Components:

- a. Adjustable Flange and Deflector: Aluminium Alloy 6063-T6
- b. Splash Guard: neoprene rubber
- c. StormSack: woven polypropylene geotextile with US Mesh 20
- d. Corner Filler: Aluminium Allow 5052-H32
- e. Lifting Tabs: Aluminium Allow 5052-H32
- f. Replaceable Oil Boom: polypropylene 3 inch (76 mm) diameter
- g. Mesh Liner: HDPE, diamond configuration
- h. Support Hardware: CRES 300 Series

Sizes:

STANDARD SPEL STORMSACK TO SUIT PIT SIZES

- 450x450mm
- 600x600mm
- 900x600mm
- 900x900mm

Custom sizes (i.e. 1200x900mm) can be manufactured on short lead times.

1. Personal Health & Safety

When carrying out maintenance operations of the SPEL StormSack all contractors and staff personnel must comply with all current workplace health and safety legislation.

The below measures should be adhered to as practically as possible:

- Comply with all applicable laws, regulations and standards
- All those involved are informed and understand their obligations in respect of the workplace health and safety legislation.
- Ensure responsibility is accepted by all employees to practice and promote a safe and healthy work environment.

2. Personal Protective Equipment

When carrying out maintenance operations of the SPEL StormSack, wearing the appropriate personal protective equipment is vital to reducing potential hazards. Personal protective equipment in this application includes:

- Eye protection
- Safety apron
- Fluorescent safety vest
- Form of skin protection
- Puncture resistant gloves
- Steel capped safety boots



3. Maintenance of the SPEL StormSacks is a specialist activity.

When carrying out maintenance operations of the SPEL StormSack, factors such as equipment handling methods, pollutants and site circumstances can impose potential risks to the maintainer and nearby civilians.

4. Captured Pollutants

The material captured by the SPEL StormSack can be harmful and needs to be handled correctly. The nature and amount of the captured pollutants depends on the characteristics of the site. Pollutants can include from organic material such as leaves and sticks through to debris such as plastics, glass and other foreign objects such as syringes.

5. Site Circumstances

It is essential that Occupational Safety and Health guidelines and site specific safety requirements are followed at all times. It is important that all following steps specified by SPEL are carried out to ensure safety in the entire maintenance operation. The general workplace hazards associated with working outdoors also need to be taken into account.

6. Equipment Handling

Handling activities such as a removing the drain grate a well as managing pedestrians and other non-worker personnel at the site should be exercised in accordance with specified safety procedures and guidelines.

7. Confined Spaces

Confined space entry procedures are not covered in this manual. It is requested that all personnel carrying out maintenance of the SPEL StormSack must evaluate their own needs for confined space entry and compliance with occupational health and safety regulations

When maintenance operations cannot be carried out from the surface and there is a need to enter confined space, only personnel that currently hold a Confined Space Entry Permit are allowed to enter the confined space. All appropriate safety equipment must be worn, and only trained personnel are permitted to use any required breathing apparatus gear. Necessary measures and controls must always be exercised to meet the confined space entry requirements. Non trained staff are not permitted to participate in any confined space entries.

8. Traffic Management

Typically stormwater gully pits are situated on roads and carparks, or adjacent to roads in a footpath or swale. As traffic requirements vary depending on the circumstance of the site, separate traffic control plans should be prepared for each site.

The specific road safety requirements for each site can be obtained from the relevant road authority to ensure all maintenance operations comply with the laws and regulations. State government publications can also be useful to find out the signage requirements, placement of safety cones and barricades that are required when working on public roads.

1. General Monitoring

The SPEL StormSack must be checked on a regular basis to analyse whether it requires maintenance or cleaning.

As gully pit grates are usually quite heavy, it is vital to exercise the correct lifting techniques and also ensure that the area surrounding the open pit is shielded from access of non-work personnel.

To ensure optimal performance of the SPEL StormSack, the material collected by the filter bag should not exceed the level of approximately a half to two thirds of the total bag depth. When this material collected is showing signs of exceeding this level they should be scheduled to be emptied.

It is also recommended that additional monitoring is conducted following moderate to extreme rainfall events, especially when previous months have had little or no rainfall.



2. Gully Pit Cover Removal

Opening a Hinged Pit Cover

- A. Insert the lifting hooks beneath the grate
- B. Check hinge points are not damaged and debris is not caught in the hinge area
- C. Fully open pit grate, ensuring that the grate will stay in the open position without any external forces applied. Grates that do not remain open without being held, should be removed or secured during maintenance activities.



Opening a Non-Hinged Pit Cover

- A. Place lifting hooks beneath grate, where possible in the four corners of the grate. Concrete lids may have Gatic lifting points, a key arrangement or holes in the lid, which may require special equipment such as Gatic lifters. Alternatively if safe to do so grip the grade with your hands.
- B. Position each person on either side of the grate.
- C. Lift the grate, ensuring that good heavy lifting posture is used at all times.
- D. Place the grate on angle on the gutter, to allow for the lifting hooks to be removed.
- E. For extremely heavy one-piece grates and concrete Gatic covers, insert the lifters in place and slide the lids back.



3. Cleaning Methods

Cleaning using an inductor truck

- A. Open Gully pit
- B. Place the indicator hose, suck out all of the sediment, organic leaf material, litter and other materials that were collected in the filter bag
- C. Allow the filter bag to be sucked up in the inductor hose for a few seconds to allow for the filter mesh pores to be cleaned.
- D. Use the inductor hose to remove any build-up of material around the overflows and in the bottom of the pit.
- E. Remove filter back from pit
- F. Remove any sediment and litter caught in the Gully pit grate
- G. Back opening channels are to be cleared of any debris to ensure flow is not hindered.
- H. Thoroughly examine the structural integrity of the filter bag and frame.
- I. Reinstate filter bag and gully pit covers

Hand Maintenance

- A. Open Gully pit
- B. Using the correct lifting technique, lift the StormSack out by the diagonal lifting corners fitted to the frame.
- C. For extremely heavy and overfilled bags either use a hydraulic lifting arm to lift the StormSack, or remove excess material using a shovel or etc. Take care not to damage the bag when removing litter form the bag.
- D. Lift the StormSack clear of the stormwater pit.



- E. Position the StormSack over the collection bin or vehicle.
- F. Lift and empty the bag by holding the bottom lifting loops only.
- G. Brush the StormSack with a stiff brush to remove the sediment from the filter pores.
- H. Thoroughly examine the structural integrity of the filter bag and frame.
- I. Reinstate StormSack and gully pit covers.



4. SPEL StormSack Post Maintenance Inspection

After the SPEL StormSack has been removed, emptied and cleaned, it should be thoroughly examined to sure that:

- There is no movement or damage to the Cage
- There is no movement or damage to the plastic pit seals
- Structural integrity is in good condition including all fixings, joints and connections.
- The filter bag pores are not clogged
- The filter bag is not damaged in anyway.

The gully pit, pipe inlet/outlets and its cover should also be inspected to ensure there is no damage, debris build up or any potential to cause the SPEL StormSack to operate inefficiently.



5. Material Disposal

Collected materials can be potentially harmful to humans and the environment.

Once all captured material from the SPEL StormSack has been removed, it must be taken off site and disposed of at a transfer station or a similar approved disposal site.

6. SPEL StormSack Repairs

Depending on the extent of the damage to the SPEL StormSack unit, it can usually be repaired.

Small tears to the filter bag can be repaired by either sewing the tear back together with additional fabric to increase the strength of the stitching, or by sewing a patch of filter material onto the filter bag.

If large tears or irreparable damage to the frame and structure are present, it is advisable to replace the components.

All required spare parts can be sourced from SPEL Environmental at a cost to the owner of the SPEL Stormsack.

7. Emergency Procedures

Spills and blockages can be detrimental to the performance of a stormwater management system, potentially damaging the surrounding built infrastructure, waterways and environment.

Spill Procedures

In the event of a spill discharging into a gully pit, all effected sediment must be removed from the filter bags and the filter bags are to be removed and replaced with new filter bags. All additional cleaning as a result of the spill should also be carried out in accordance with the normal operation procedures.

Blockages

In the unlikely event of surface flooding around a gully pit which has a SPEL StormSack fitted, the following steps should be carried out:

- A. Check the overflow bypass.
- B. If overflow is clear and surface flooding still exists remove the SPEL StormSack and check the outlet pipe for blockages. Removal of the SPEL StormSack can be difficult if clogged with sediment and holding water.
- C. If the filter is clogged brush the side walls to dislodge particles trapped at the interface allowing water to flow through the filter.
- D. If the outlet pipe is blocked, it is likely that a gully sucker truck will be required to unblock it. Litter can be removed from the SPEL StormSack using the gully sucker truck before the SPEL StormSack is removed. If a gully sucker truck is not available and the SPEL StormSacks need to be removed by hand follow the below steps.
 - i. Remove excess debris by hand or brush the side of the filter bag
 - ii. Remove entire SPEL Stormsack by taking hold of the inside of the frame.
 - iii. Unblock the outlet pipe



HEAD OFFICE

PO Box 6144
Silverwater NSW 1811

100 Silverwater Rd
Silverwater NSW 2128

Phone: +61 2 8705 0255

Fax: +61 2 8014 8699



DESIGN OFFICES

New South Wales 61 2 8705 0255

Canberra 61 2 6128 1000

Queensland 61 7 3271 6960

Victoria & Tasmania 61 3 5274 1336

South Australia 61 8 8275 8000

West Australia 61 8 9350 1000

Northern Territory 61 2 8705 0255

New Zealand 64 9 276 9045



www.spel.com.au

SPEL Environmental accepts no responsibility for any loss or damage resulting from any person acting on this information. The details and dimensions contained in this document may change, please check with SPEL Environmental for confirmation of current specifications.

SPELFilter®

Cartridge filter for tertiary stormwater treatment



spelstormwater
joy in water

spel.com.au

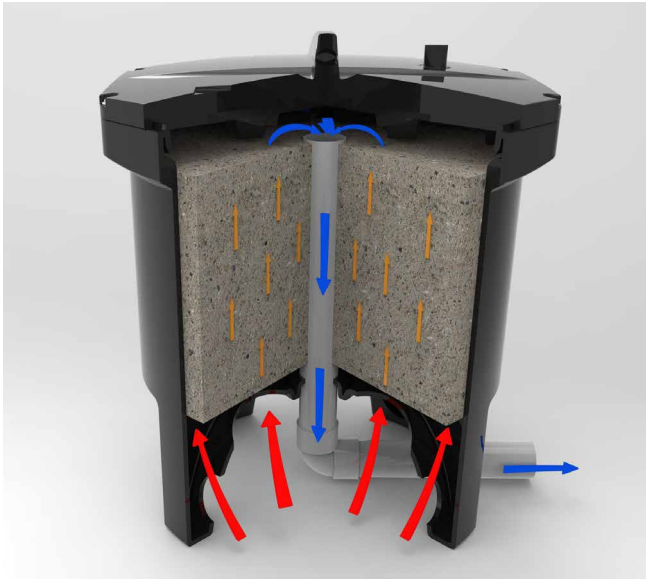

APPLICATIONS

- Car Parks and Shopping Centres
- Council Depots
- Industrial Estates
- Heavy Vehicle Maintenance
- Airport Aprons & Tarmacs
- Transport Depots & Loading Bays
- Tunnels
- Highways & Transport Corridors
- Recycling Yards

SPELFilter is a cartridge filter system that incorporates an upflow treatment process that maximises surface treatment area. Flow through the filter cartridges utilises a self-regulating siphon which results in a low maintenance and high performance stormwater treatment. The automatic backwash at the end of each storm event further lengthens the lifespan of the filter.

Hydraulic pressure forces water through the filter media — causing a constant velocity throughout the filter area realising a consistent media contact time and therefore treatment.

Upon completion of a treatment cycle, the filter backwashes and effectively dislodges particulates from the filtration layers. This re-establishes filter media porosity. The dislodged particles then accumulate away from the filter media allowing easy removal during maintenance.

FEATURES

The media cartridge provides a significantly greater surface contact area to footprint ratio than other filters. With a flow rate of 3L/s per cartridge and underground installation, the SPELFilter provides excellent removal efficiency whilst maintaining site surface yield.

- No moving parts, generating a true siphon effect
- 91% TSS, 75% TP and 58% TN removal
- Small footprint
- Inorganic filter media (doesn't leach nutrients)
- Can be deployed in various drainage structures such as manholes & vaults
- Contains no moving parts





BENEFITS

PROVEN SAND FILTER PERFORMANCE

The uniform size silica-sand filter media provides for higher removal efficiencies than coarser types of media. SPELFilter media is inorganic – it doesn't leach nitrogen and other nutrients.

Each SPELFilter automatically backflushes under gravity. The backflush clears most sediment particles from out of the the media and back into the vault floor, which allows the hydraulic conductivity from degrading throughout its service life. No moving parts are involved, which increases reliability. The SPELFilter cartridge design life is in excess of 5 years.

HOW IT WORKS

The SPELFilter has an upflow treatment process, that maximises surface area. The benefit is excellent pollutant removal in a small footprint.

Hydraulic pressure forces water through the filter media, discharges through the centre tube and out through the outlet collection manifold.

Upon completion of a treatment cycle, each cartridge backwashes and effectively dislodges particulates from the filtration layers. This reestablishes filter media porosity. The dislodged particles accumulate on the vault floor for easy removal during maintenance. SPELFilter's design has no moving parts and generates a true siphon effect.

A SPEL Stormceptor Class 1 upstream of the SPELFilter in the treatment train greatly increases the life cycle interval of the SPELFilter as the SPEL Stormceptor Class1 removes the larger gross pollutants, coarse sediments, total suspended solids and hydrocarbons, enabling the SPELFilter to target fine particulate matter and nutrients.



FLEXIBILITY

Due to the greater surface area and high flow capacity, combined with the modular cartridge design, the SPELFilter systems can be deployed in a variety of structures including manholes, precast vaults, or cast-in-place structures.

Each system is optimised to suit your specific site and local authority requirements by qualified and experienced professionals.



DRAWINGS

Rectangle Fibreglass Installation

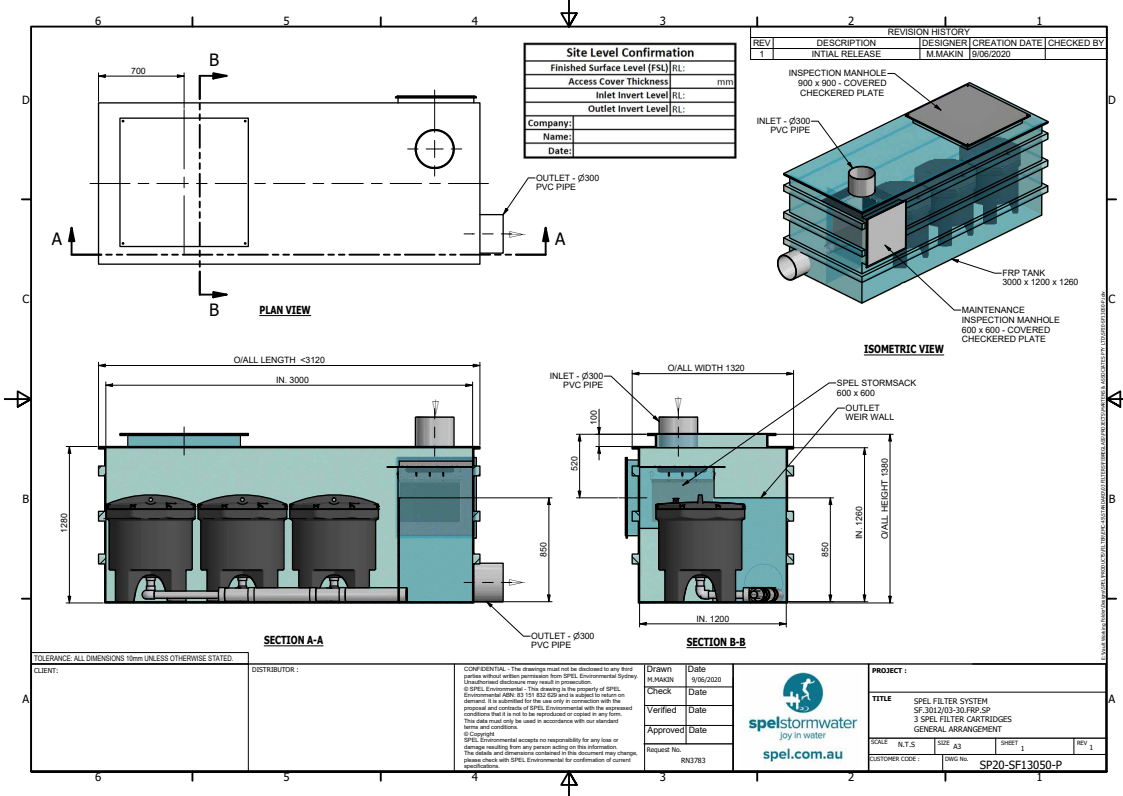

Round Fibreglass Tank Installation

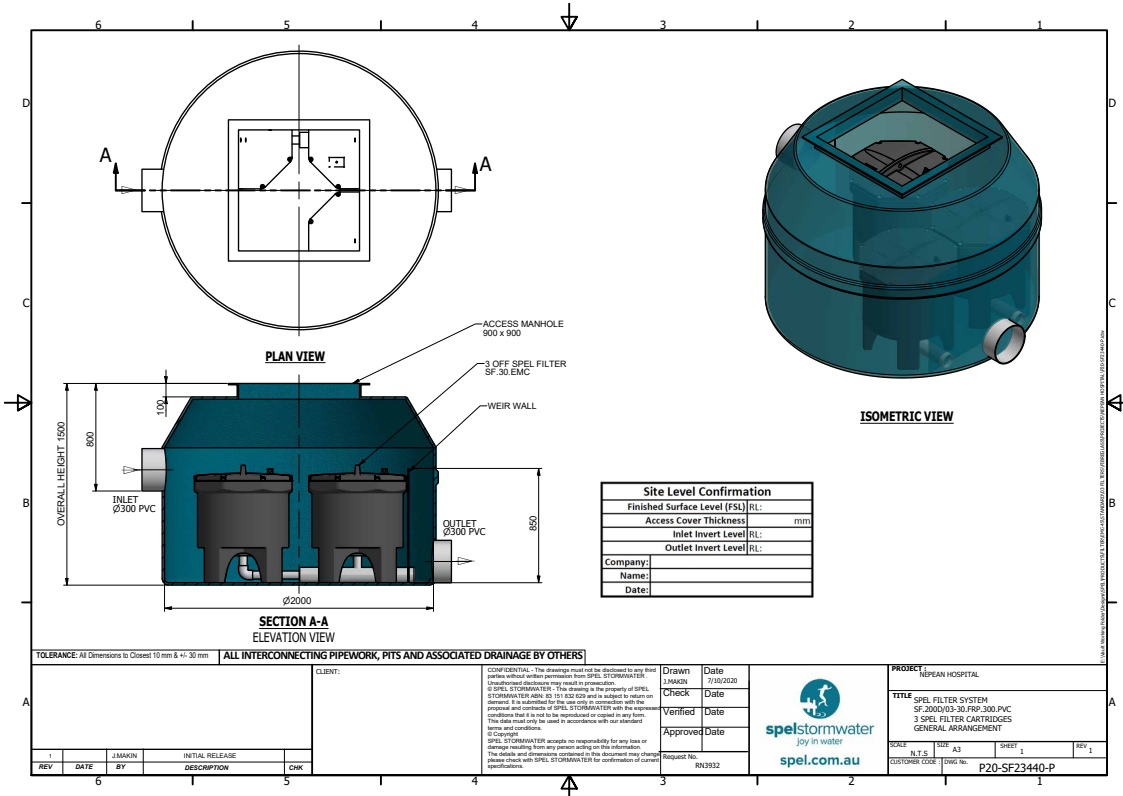

DRAWINGS

Rectangle Concrete Installation

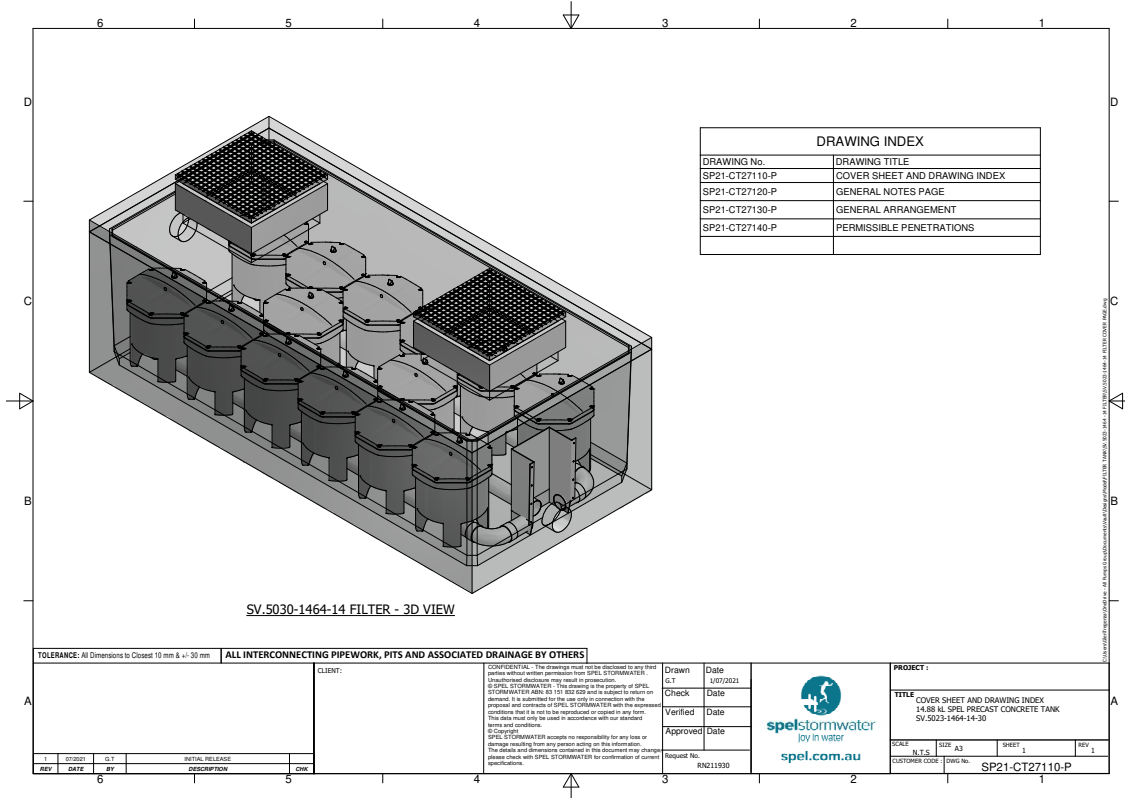

Round Concrete Tank Installation

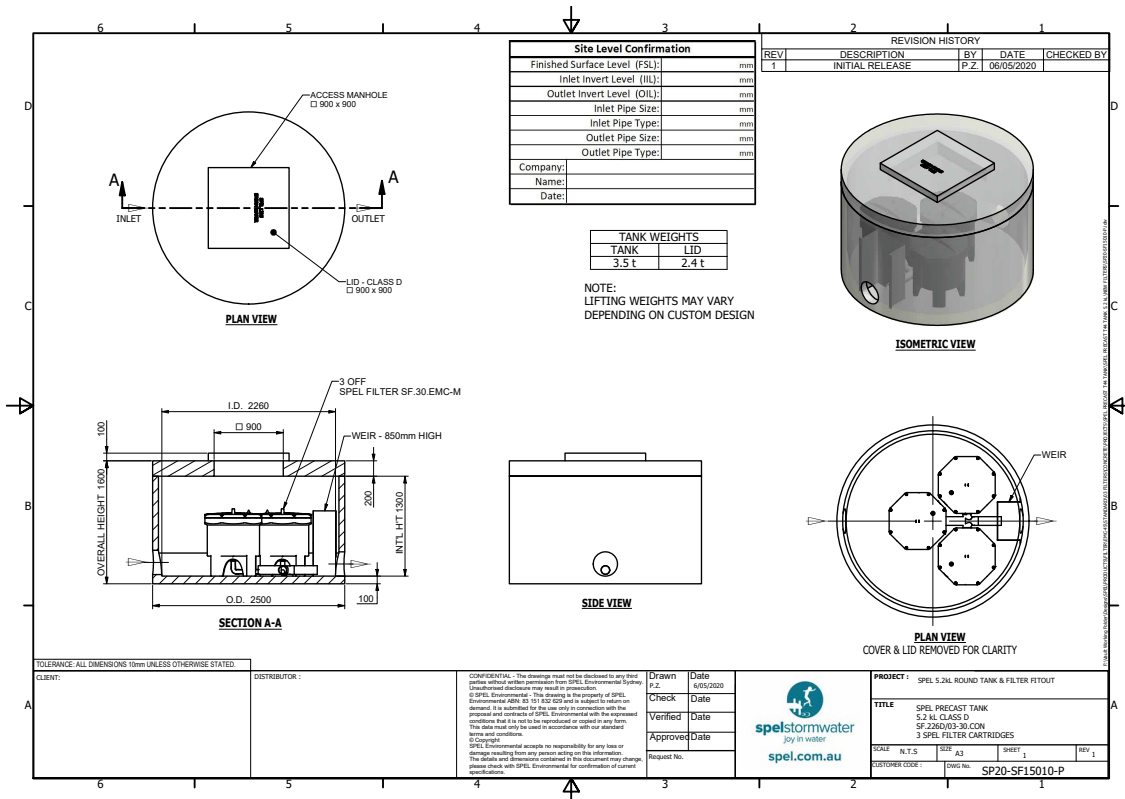

DRAWINGS

Modular Filtration Tank Installation

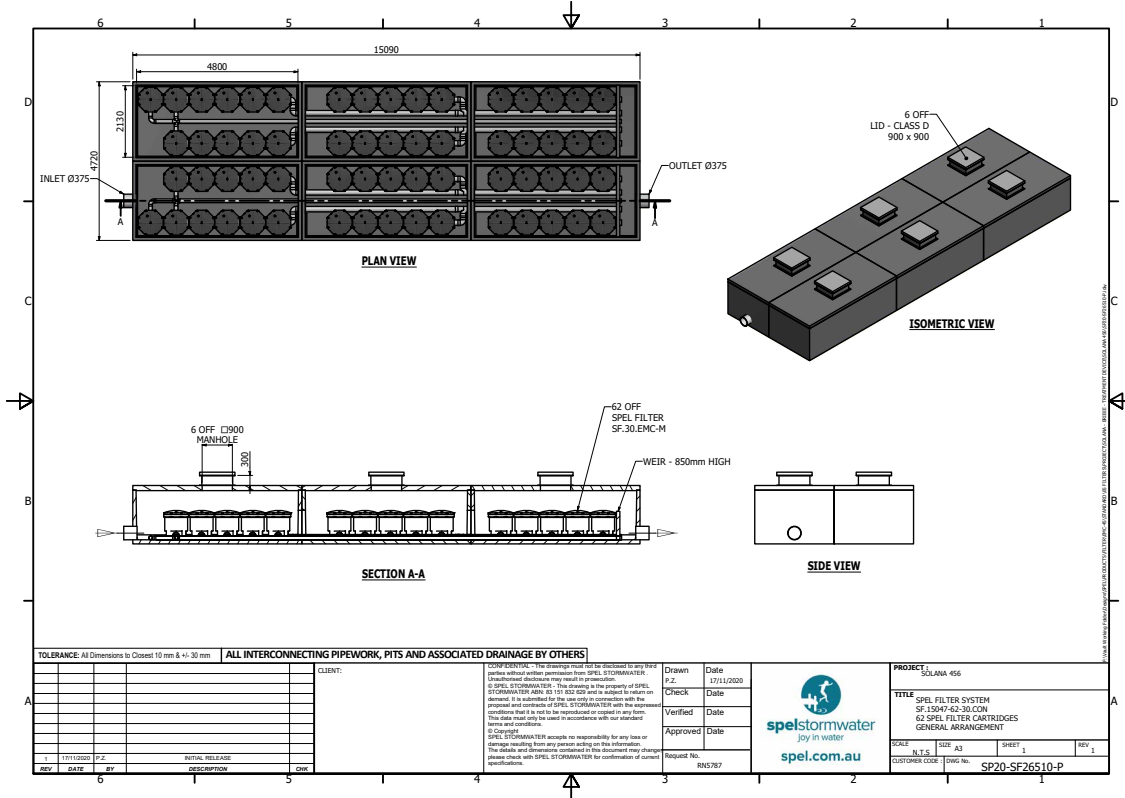

Internal Bypass Arrangement Tank

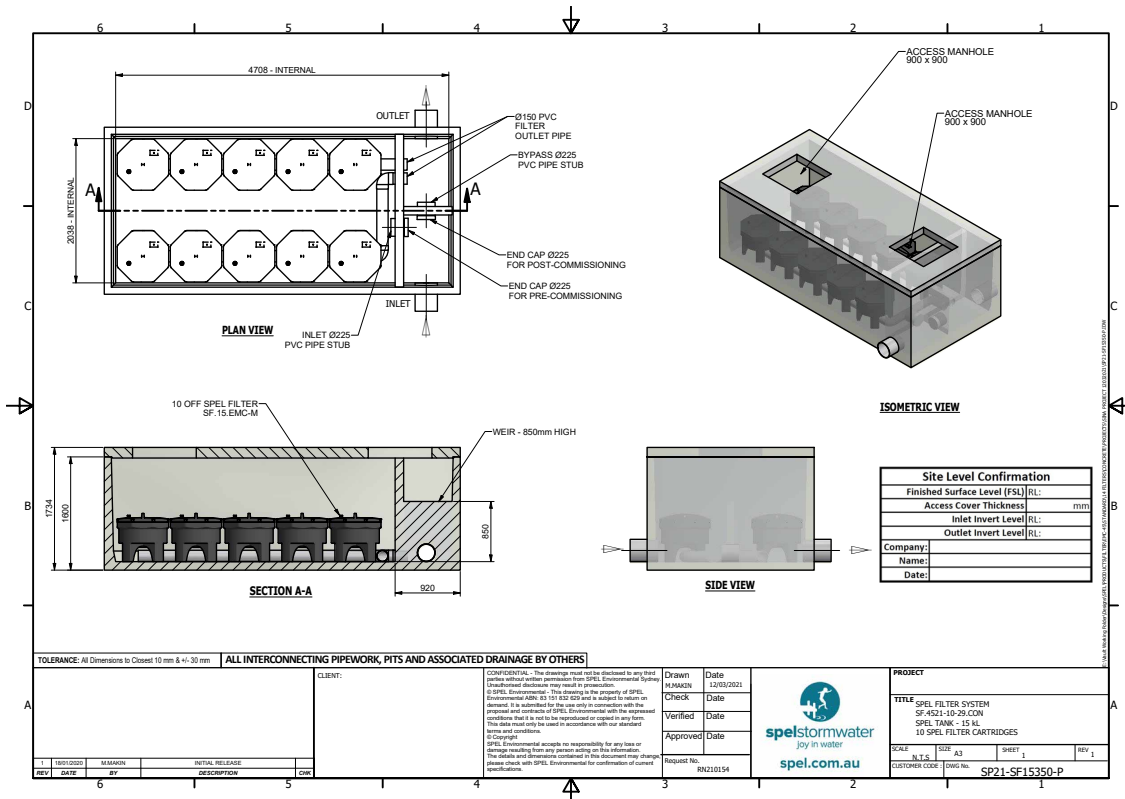

SPELFilter[®]

Cartridge filter for tertiary stormwater treatment

<p>NSW HEAD OFFICE 100 Silverwater Rd, Silverwater NSW 2128 PO Box 7138, Silverwater NSW 1811 P: +61 2 8705 0255 P: 1300 773 500 E: nsw.sales@spel.com.au</p>	<p>QLD MAIN OFFICE 130 Sandstone Pl, Parkinson QLD 4115 P: +61 7 3271 6960 P: 1300 773 500 E: qld.sales@spel.com.au</p> <p>QLD SUNSHINE COAST BRANCH 19-27 Fred Chaplin Circuit, Bells Creek, QLD 4551 P: 1300 773 500 E: qld.sales@spel.com.au</p>	<p>VIC & TAS OFFICE 897 Wellington Rd Rowville VIC 3178 P: +61 3 5274 1336 P: 1800 810 139 E: sales@spel.com.au</p> <p>VIC GEELONG BRANCH 70 Technology Close, Corio, P: +61 3 5274 1336 P: 1800 810 139 E: sales@spel.com.au</p>
<p>SA OFFICE 9 Hampden Road, Mount Barker SA 5251 P: 1300 773 500 E: sales@spel.com.au</p>	<p>WA OFFICE 2 Modal Crescent Canning Vale WA 6155 P: +61 8 9350 1000 P: 1800 335 550 E: sales@spel.com.au</p>	<p>NZ OFFICE AUCKLAND 100 Montgomerie Road Airport Oaks P: +64 9 276 9045 E: sales@spel.com.au</p>
<p>NZ OFFICE WANGANUI 43 Heads Road Wanganu New Zealand P: +64 6 349 0088 E: sales@spel.com.au</p>	<p>NZ OFFICE WELLINGTON 41 Raiha St Porirua Wellington New Zealand P: +64 4 239 6006 E: sales@spel.com.au</p>	<p>PHILIPPINES OFFICE METRO MANILA Unit 2210 Lumiere Residences Pasig Boulevard, Pasig City P: +61 2 8705 0255 P: 1300 773 500 E: sales@spel.com.au</p>
<p>SINGAPORE OFFICE 512 Chai Chee Lane, #06-04 Bedok Industrial Estate, Singapore 469028 P: +61 2 8705 0255 P: 1300 773 500 E: sales@spel.com.au</p>	<p>UK OFFICE UNITED KINGDOM Lancaster Rd Shrewsbury SY1 3NQ UK P: +44 (0)1743 445200 E: sales@spel.com.au</p>	<p>USA OFFICE CLEVELAND 4548 Industrial Parkway Cleveland, Ohio 44135 P: +61 2 8705 0255 P: 1300 773 500 E: sales@spel.com.au</p>

We believe clean water is a right not a privilege and we work to ensure a joy in water experience for you with your children and grandchildren.

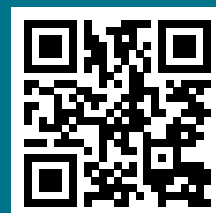

100 Silverwater Rd, Silverwater NSW 2128 Australia

Phone: (02) 8705 0255

Email: sales@spel.com.au

spel.com.au

SPEL Stormwater accepts no responsibility for any loss or damage resulting from any person acting on this information. The details and dimensions contained in this document may change, please check with SPEL Stormwater for confirmation of current specifications.



SPELFilter

Cartridge Filter For Tertiary Stormwater Treatment

www.spel.com.au

SPEL ENVIRONMENTAL
INTEGRATED WATER SOLUTIONS

SPEL FILTER

Where intuitive technology meets value.

SPEL Applications Engineers are ready to design a custom SPELFilter system to meet the demands of your site.

SPELFilter provides the performance of a biofiltration system without the surface footprint disadvantage of vegetated assets. SPELFilter maximises your land use on constrained sites.



Features

- » Greater than 90% TSS Removal
- » Greater than 54% reduction in Total Phosphorus; including Dissolved Phosphorus
- » Greater than 36% reduction in Total Nitrogen; including Dissolved Nitrogen
- » Greater than 50% reduction in turbidity

How it works

The SPELFilter has an upflow treatment process, that maximises surface area. The benefit is excellent pollutant removal in a small footprint.

Hydraulic pressure forces water through the filter media, discharges through the centre tube and out through the outlet collection manifold.

Upon completion of a treatment cycle, each cartridge backwashes and effectively dislodges particulates from the filtration layers. This reestablishes filter media porosity. The dislodged particles accumulate on the vault floor for easy removal during maintenance.

SPELFilter's patented design has no moving parts and generates a true siphon effect.

A SPEL Stormceptor Class 1 upstream of the SPELFilter in the treatment train greatly increases the life cycle interval of the SPELFilter as the SPEL Stormceptor Class1 removes the larger gross pollutants, coarse sediments, total suspended solids and hydrocarbons, enabling the SPELFilter to target fine particulate matter and nutrients.



Value & Benefits

Proven Sand Filter Performance:

The uniform size silica-sand filter media provides for higher removal efficiencies than coarser types of media. SPELFilter media is inorganic – it doesn't leach nitrogen and other nutrients.

Greater flexibility:

Due to the significant surface area, designated flow path and high flow capacity, combined with the modular cartridge design, the SPELFilter system can be deployed in a variety of structures including manholes, precast vaults, or cast-in-place structures.

Each system is optimised to suit your specific site and local authority requirements by qualified and experienced professionals.

Filter Configurations

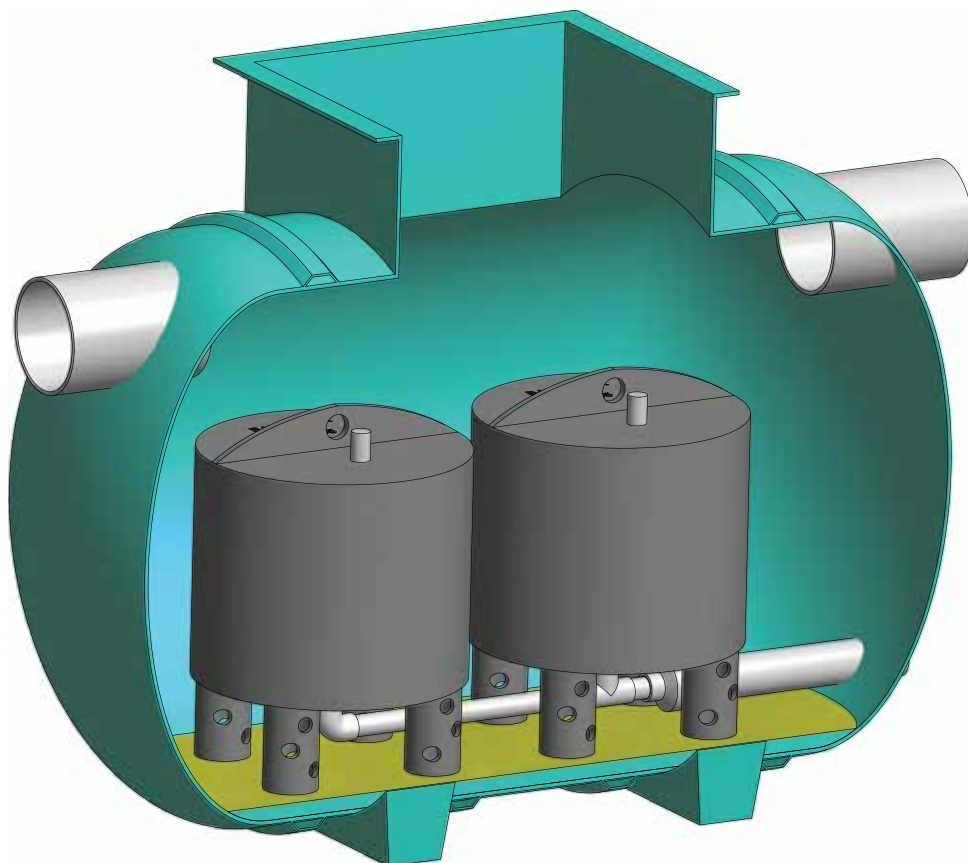



HEAD OFFICE

PO Box 6144
Silverwater NSW 1811

100 Silverwater Rd
Silverwater NSW 2128

Phone: +61 2 8705 0255

Fax: +61 2 8014 8699



DESIGN OFFICES

New South Wales 61 2 8705 0255

Canberra 61 2 6128 1000

Queensland 61 7 3271 6960

Victoria & Tasmania 61 3 5274 1336

South Australia 61 8 8275 8000

West Australia 61 8 9350 1000

Northern Territory 61 2 8705 0255

New Zealand 64 9 276 9045



www.spel.com.au

SPEL Environmental accepts no responsibility for any loss or damage resulting from any person acting on this information. The details and dimensions contained in this document may change, please check with SPEL Environmental for confirmation of current specifications.



**Operation &
Maintenance Manual**

Spel Filter[®]

Cartridge Filter For Tertiary Stormwater Treatment



spel.com.au

Contents

Introduction.....	3
Features.....	4
Sizes	6
System Configuration.....	7
Health and Safety.....	8
Maintenance frequency.....	10
Maintenance Procedure	11
General Cleaning	12
Cartridge Recycling and Replacement	13
Standard Drawings	14
Site Exit & Clean Up	16



Introduction

Understanding how to correctly and safely maintain the SPELFilter is essential for the preservation of the filter's condition and its operational effectiveness. The SPELFilter is a highly engineered stormwater filtration device designed to remove sediments, heavy metals, nitrogen and phosphorus from stormwater runoff.

The filters can be housed in either a concrete or fibreglass structure that evenly distributes the flow between cartridges.

Flow through the filter cartridges is gravity driven and self-regulating, which makes the SPELFilter system a low maintenance, high performance stormwater treatment device.

This Guide will provide the necessary steps that are to be taken to correctly and efficiently ensure the life of the SPELFilter product



Figure 1 - SPELFilters in a concrete chamber / vault

Features

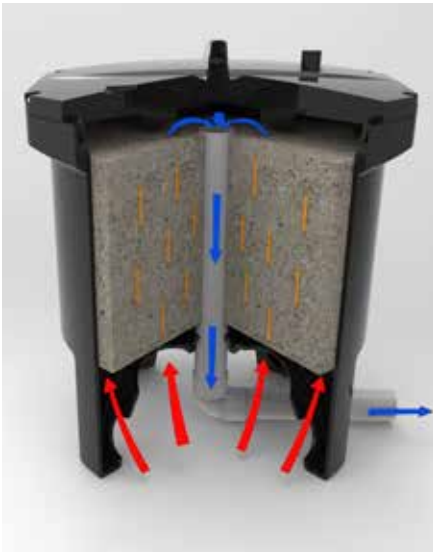

Figure 2 - Diagram of water flow through SPELFilter

The SPELFilter has a patented design that facilitates influent flow over the entire surface area of the media, providing consistent pollutant removal within a small footprint.

The SPELFilter provides highly effective media filtration using gravity flow conditions, without the need for moving parts or floating valves. This eliminates the risk of mechanical failure, such as stuck valves and seizing components during its service life. This provides highly robust treatment performance.

Hydraulic head provided by a suitably sized weir in the filter vault forces stormwater through the filter media via the inlet ports underneath the filter cartridge. Refer to the table below for minimum head required for the SPELFilter cartridges to assist in sizing the weir.

The water to be treated enters the SPELFilter cartridge via an upwards direction as the water level builds up around the SPELFilter. This 'up flow' reduces the amount of sediment that could enter the media cartridge, as the sediment is allowed to drop to the vault floor under gravity. Any remaining sediment in the water is introduced through the filter media under hydraulic pressure and is filtered.

Water is filtered through the media, where dissolved and particulate Total Nitrogen and Total Phosphorus are removed via reaction with the media, in addition to the removal of Total Suspended Solids / sediment.

SPELFilter Media Self-Backwash feature

A one-way air release valve located at the top of the filter cartridge allows air to escape as the cartridge fills up with water. This creates a siphonic flow condition as the air is completely evacuated from inside the SPELFilter cartridge. Siphonic flow conditions are maintained until such time the water level outside of the cartridge falls beneath the inlet ports underneath the filter. At this moment, the water level inside the SPELFilter cartridge is higher than the surrounding water level. The water inside the SPELFilter cartridge is then expelled upon the break of the siphon, and the water flows down and out of the inlet ports under gravity, onto the vault floor.

This is a highly effective backwash of the media and allows the expulsion of a high proportion of sediment out from the SPELFilter media. The expelled sediment can be removed either manually or with a vacuum from the vault floor.

This backwash effect allows the media to remain highly conductive and is the key to the industry leading longevity of the SPELFilter cartridge system, which does not need replacement for at least 5 years, and typically will achieve up to 6-8 years of service, subject to the SPELFilter being regularly maintained in accordance with this guideline and in accordance with the specific needs of the catchment.



Figure 3 - Typical Outlet Weir Wall

Features

Self Supporting Feet

Each SPELFilter cartridge stands on 4 feet, which negates the need for the construction of a false floor in the vault. The feet are bolted to the vault floor with the supplied stainless steel angles and M10 bolts. The feet allow a clear height from the vault floor up to the inlet ports of 240mm. The absence of a false floor allows plenty of room for backwashed sediment to evacuate from underneath the cartridges and thereby avoid blocking the inlet ports to the SPELFilter from sediment buildup. It is for this reason that SPEL recommended the sediment buildup not exceed 150mm above the vault floor, so as to avoid blocking the inlet ports of the SPELFilter. Blockage of the inlet ports due to sediment accumulation in the vault floor will cause the SPELFilter to go into bypass and be ineffective. Hence it is important to keep up to date with monitoring and maintaining the SPELFilter vault.



Figure 4 - Bolting the feet



Figure 5 - Underside of the SPELFilter showing the screened inlet ports and the connection for the outlet pipe in the middle



Figure 6 - the top of the SPELFilter showing the location of the one way air valve

Sizes

SPEL Stormwater manufactures two height cartridges for varying site constraints as shown below. Each cartridge is designed to treat stormwater at a flow rate of 1.47 Litres per second and 2.83 Litres per second for the half-height cartridge (model No. SF.15-EMC-M) and full-height cartridge (model No. SF.30-EMC-M) respectively.

	Full Height SF.30-EMC -M	Half height SF.15-EMC-M
SPELFilter total height	874mm	560mm
SPELFilter Diameter	726mm	726mm
Minimum Head required	850mm	550mm
Treatment flow rate	3 L/s	1.5 L/s
Height of inlet ports above vault floor	250mm	250mm
Filtered water collection pipe diameter	50mm	50mm

SPELFilter Full Height- SF.30-EMC-M



SPELFilter Half Height - SF.15-EMC-M



System Configuration

SPELFilter cartridges are installed in concrete or fibreglass tanks commonly referred to as 'vaults'. The vault selection and configuration are based on site characteristics and/or constraints; computational stormwater quality modelling; and selected SPELFilter models. Typical SPELFilter system configurations are shown below.

In-line SPELFilter Configuration

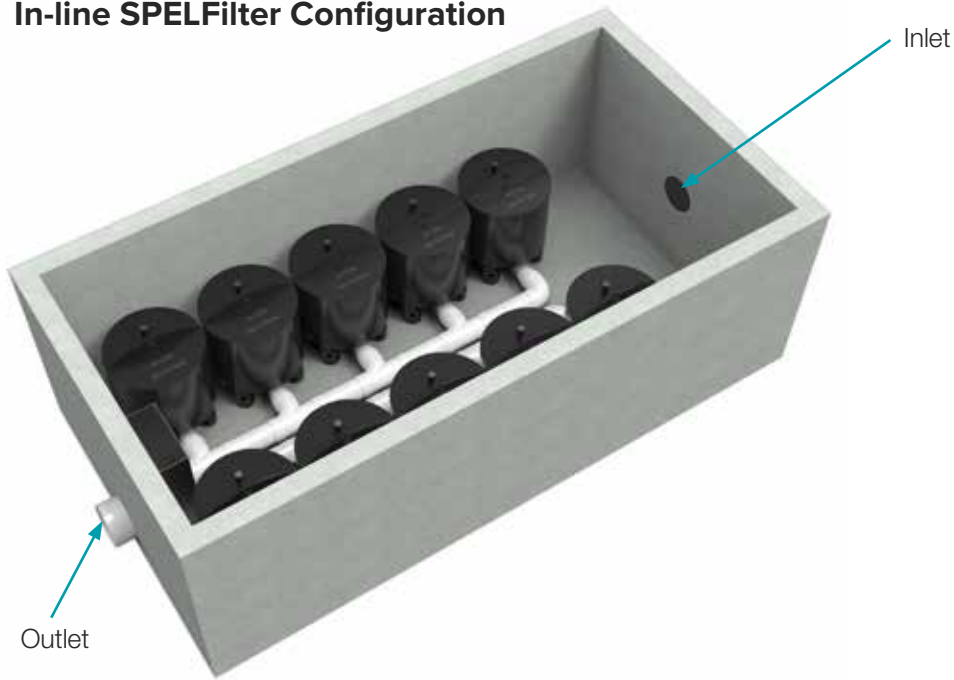

Off-line SPELFilter Configuration

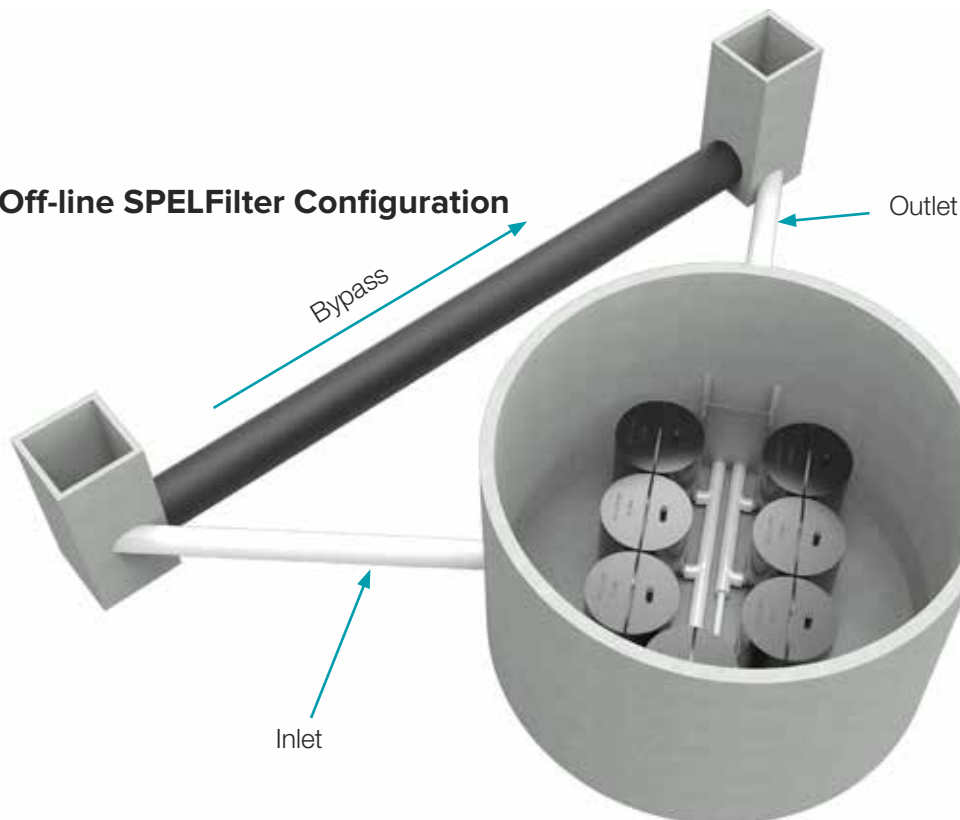

Health and Safety

A. Personal Health & Safety

When carrying out the necessary installation operations of the SPEL Filter all contractors and staff personnel must comply with all current workplace health and safety legislation.

The below measures should be adhered to as practically as possible.

- Comply with all applicable laws, regulations and standards
- All those involved are informed and understand their obligations in respect of the workplace health and safety legislation.
- Ensure responsibility is accepted by all employees to practice and promote a safe and healthy work environment.

B. Personal Protective Equipment / Safety equipment

When carrying out the necessary installation operations of the SPEL Filter, wearing the appropriate personal protective equipment and utilising the adequate safety equipment is vital to reducing potential hazards.

Personal protective equipment / safety equipment in this application includes:

- Eye protection
- Safety apron
- Fluorescent safety vest
- Form of skin protection
- Puncture resistant gloves
- Steel capped safety boots
- Ear muffs
- Hard hat/s
- Sunscreen

C. Confined space

In the event access is required into the vault, confined space permits will be required which is not covered in this Guide. Typical equipment required for confined space entry include:

- Harness
- Gas detector
- Tripod
- Spotter

D. Traffic Control

It is not uncommon for SPEL Filter cartridges to be installed underneath trafficable areas. Minimum traffic control measures will need to be put in place in accordance with traffic control plans set out by respective local and state road authorities.



Vaults are to be treated as confined space. Entry by permit only.



Monitor weather conditions prior to operation maintenance. Do not enter a vault during an episode of heavy rain as this can create a risk of drowning.





Maintenance Frequency

The SPELFilter's design allows for a greater life span when frequently maintained. Maintenance is broken up into three categories which include: standard inspection; general cleaning; and cartridge replacement.

Standard inspection

Standard inspections are conducted at regular four-month intervals. At this time, an approved trained maintenance officer or SPEL representative shall undertake all measures outlined in Maintenance Procedure, Standard Inspection.

General Cleaning

At the end of each standard inspection, trigger measures will identify if general cleaning is required. General cleaning will need to be executed immediately during standard inspections if the following triggers are satisfied:

- Build-up of debris/pollutants within the vault greater than 150mm;
- Accumulation of debris/pollutants on the outlet chamber of the SPELFilter vault;
- After large storm events, tidal or flooding impacts at the request of the owner;

Cartridge Replacement

Stormwater treatment is dependent on the effectiveness of the SPELFilter cartridge system. As the SPELFilter ages, pollutants will inundate the cartridge and ultimately reduce the treatment flow rate. At this point, a SPELFilter flow test apparatus will be utilized to determine if replacement cartridges are required.

Based on the [site] concept modelling (MUSIC) and previous industry experience, we estimate the life of the SPELFilter to be between 6 - 8 years. As a minimum requirement, each SPELFilter cartridge should be replaced within 10 years.

The life cycle of the SPELFilter can be impacted if standard inspections and general maintenance is not undertaken in accordance with this operation and maintenance Guide. Other factors that will affect the above life cycle of the SPELFilter include:

- Installation of cartridge system during construction phase and impacted by construction sediment loads;
- Neglecting to install pre-treatment using an industry approved GPT or a surface inlet pit trash bag such as the SPEL StormSack.
- Unforeseen environmental hazards affecting the SPELFilter functionality.

Maintenance Procedures

Stormwater pollutants captured and retained by the SPELFilter system need to be periodically removed to ensure environmental values are upheld. All associated maintenance works is heavily dependent on the site's operational activities and generated stormwater pollutants. To ensure the longevity of the installed SPELFilter treatment system, it is imperative that the procedures detailed in this Guide are followed and all appropriate measures are actioned immediately.

Standard inspection

The standard inspection requires personal experience of SPEL products to visual inspection the vault and filter conditions.

Confined space requirements may not be required if a full inspection and assessment of each SPELFilter can be achieved at surface level without being deemed a confined space entry.

The standard inspection requires personal experience of SPEL products to visual inspection the vault and filter conditions.

Confined space requirements may not be required if a full inspection and assessment of each SPELFilter can be achieved at surface level without being deemed a confined space entry.

Site Inspection Procedures

1. Implement Pre-start safety measures.

Ensure that the area in which operational works are to be carried out is cordoned off, to prevent unauthorised access. Adequate safety barriers must be erected. Area in which work is to be carried out must be clean, safe and hazard free. (Refer to figure 4.)

2. Set-up Gantry Tri-pod above Manhole.

Assemble and position the gantry above the manhole safely and as practically as possible. Attach the winch or chain block to the gantry for lifting the SPEL Filters. Perform safety procedures ie. Attach harnesses etc. (if confined space).

3. Open manhole lid.

Once you have sent up the Gantry and ensured that the area is safe to operate in, you can proceed to open the manhole lid, using lid lifters.

4. Conduct Gas tests.

(If tank is classed confined space)

Once the lids have been removed to a safe distance to prevent tripping, you must then proceed to conduct gas tests. Perform necessary gas tests according to the confined space regulations.

5. Once confined space has been deemed safe to operate in, enter tank safely.

Once you have carried out the required gas test and the work area is deemed safe, you may then enter the pit via a ladder or winch system to assess the work area you will be operating in. Ensure all confined space

6. SPELFilter system assessment.

Perform a review of the SPELFilter system using the SPELFilter assessment report/checklist. Sign off and forward a copy of the report to property manager and SPEL representative.

7. Reinstate SPELFilter system and disposal.

At the completion of the site inspection, ensure the site is reinstated back to its initial state and all pollutants are removed from the site in line with pollutant disposal procedures.

8. Sign off and forward a copy of the report to property manager and SPEL representative.

General Cleaning

Vacuum out of Filter tank, removal, and disposal of pollutants at the completion of a standard inspection, general cleaning may be deemed necessary immediately or scheduled for a future date. Steps undertaken for general cleaning should be in general accordance with the procedure outlined below but not limited.

1. Implement Pre-start safety measures.

Ensure that the area in which operational works are to be carried out is cordoned off, to prevent unauthorised access. Adequate safety barriers must be erected. Area in which work is to be carried out must be clean, safe and hazard free. (Refer to figure 4.)

2. Set-up Gantry Tri-pod above Manhole.

Assemble and position the gantry above the manhole safely and as practically as possible. Attach the winch or chain block to the gantry for lifting the SPEL Filters. Perform safety procedures ie. Attach harnesses etc. (if confined space).

3. Open manhole lid.

Once you have sent up the Gantry and ensured that the area is safe to operate in, you can proceed to open the manhole lid, using lid lifters.

4. Conduct Gas tests.

(If tank is classed confined space)

Once the lids have been removed to a safe distance to prevent tripping, you must then proceed to conduct gas tests. Perform necessary gas tests according to the confined space regulations.

5. Once confined space has been deemed safe to operate in, enter tank safely.

Once you have carried out the required gas test and the work area is deemed safe, you may then enter the pit via a ladder or winch system to assess the work area you will be operating in. Ensure all confined space

6. SPELFilter system assessment.

Perform a review of the SPELFilter system using the SPELFilter assessment report/checklist.

7. Pollutant removal from tank.

Perform clean-up using a licenced vacuum truck contractor or wet/dry vacuum, depending on level of sediment built up and/or tank size.

8. Reinstate SPELFilter system and disposal.

At the completion of the site inspection, ensure the site is reinstated back to its initial state and all pollutants are removed from the site in line with pollutant disposal procedures.

9. Sign off and forward a copy of the report to property manager and SPEL representative.

Cartridge Recycling and Replacement

SPELFilter cartridges can be swapped out for new cartridges. The spent SPELFilter cartridges can be collected from site and sent to SPEL Stormwater's facilities – where the spent media will be removed from the cartridge in factory conditions and disposed of in accordance with environmental regulations.

The SPELFilter cartridge will be recharged with new media – thereby recycling and repurposing the cartridge.

SPEL Filter replacement procedures may vary depending on the configuration of the SPEL Filters, the type of vault and engineers' specs. Replacement instructions for manhole SPEL Filter systems and precast vault SPEL Filter systems are contained in this section.

At the completion of a standard inspection, SPEL Filter replacement may be deemed necessary immediately or scheduled for a future date. Steps undertaken for cartridge replacement should be in general accordance with the procedure outlined below but not limited.

1. Implement Pre-start safety measures.

Ensure that the area in which operational works are to be carried out is cordoned off, to prevent unauthorised access. Adequate safety barriers must be erected. Area in which work is to be carried out must be clean, safe and hazard free.

2. Set-up Gantry Tri-pod above Manhole.

Assemble and position the gantry above the manhole safely and as practically as possible. Attach the winch or chain block to the gantry for lifting the SPEL Filters. Perform safety procedures ie. Attach harnesses etc. (if confined space).

3. Open manhole lid.

Once you have sent up the Gantry and ensured that the area is safe to operate in, you can proceed to open the manhole lid, using lid lifters.



4. Conduct Gas tests. (If tank is classed confined space)

Once the lids have been removed to a safe distance to prevent tripping, you must then proceed to conduct gas tests. Perform necessary gas tests according to the confined space regulations.

5. Once confined space has been deemed safe to operate in, enter tank safely.

Once you have carried out the required gas test and the work area is deemed safe, you may then enter the pit via a ladder or winch system to assess the work area you will be operating in. Ensure all confined space procedures are followed.

6. Remove exhausted cartridges.

Disconnect all internal pipe work from inside the vault. Un-bolt anti-floatation measures and remove cartridges from the vault using Gantry Tri-pod method.

7. Pollutant removal.

Using a wet/dry vacuum or sucker truck, suck out all the residual pollutant from the vault.

8. Install pipework and SPEL Filters.

Please refer to the below standard install diagrams for the SPEL Filters. Then refer to your site specific drawings, as site requirements may require something different to the standard layout. Lower filters into tank, position into place, connect filter outlet pipework with the supplied fittings.

9. Install anti-floatation system.

Please refer to the detailed drawings showing how the Anti – Floatation (Anchor) bars are to be installed.

10. Sign off and forward a copy of the report to property manager and SPEL representative.

ISSUE FOR APPROVAL
NOT FOR CONSTRUCTION

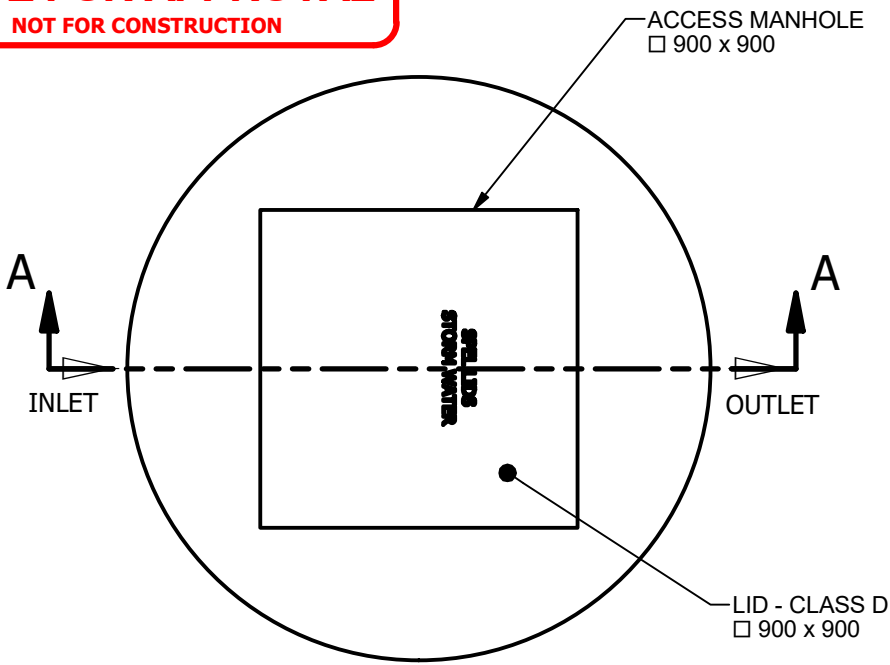

PLAN VIEW

Site Level Confirmation	
Finished Surface Level (FSL):	mm
Inlet Invert Level (IIL):	mm
Outlet Invert Level (OIL):	mm
Inlet Pipe Size:	mm
Inlet Pipe Type:	mm
Outlet Pipe Size:	mm
Outlet Pipe Type:	mm
Company:	
Name:	
Date:	

APPROVED.....

NAME.....

SIGNED.....

DATE...../...../.....

TANK WEIGHTS	
TANK	LID
2.5 t	1.8 t

NOTE:
LIFTING WEIGHTS MAY VARY
DEPENDING ON CUSTOM DESIGN

REVISION HISTORY				
REV	DESCRIPTION	BY	DATE	CHECKED BY
1	INITIAL RELEASE	P.Z.	4/06/2020	

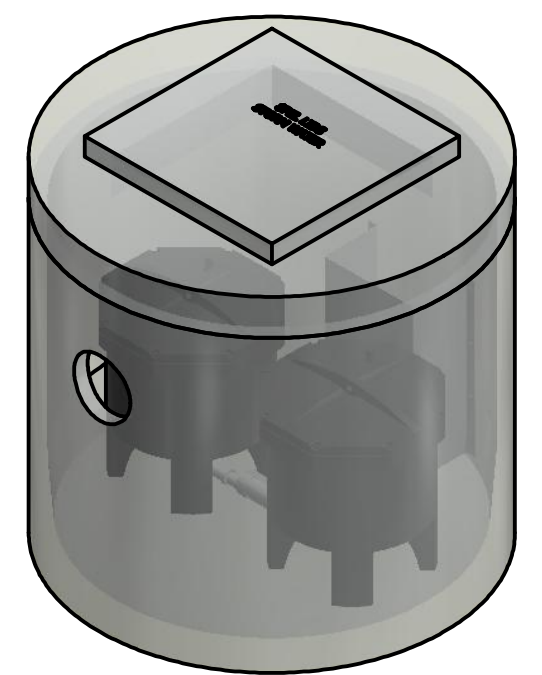

ISOMETRIC VIEW

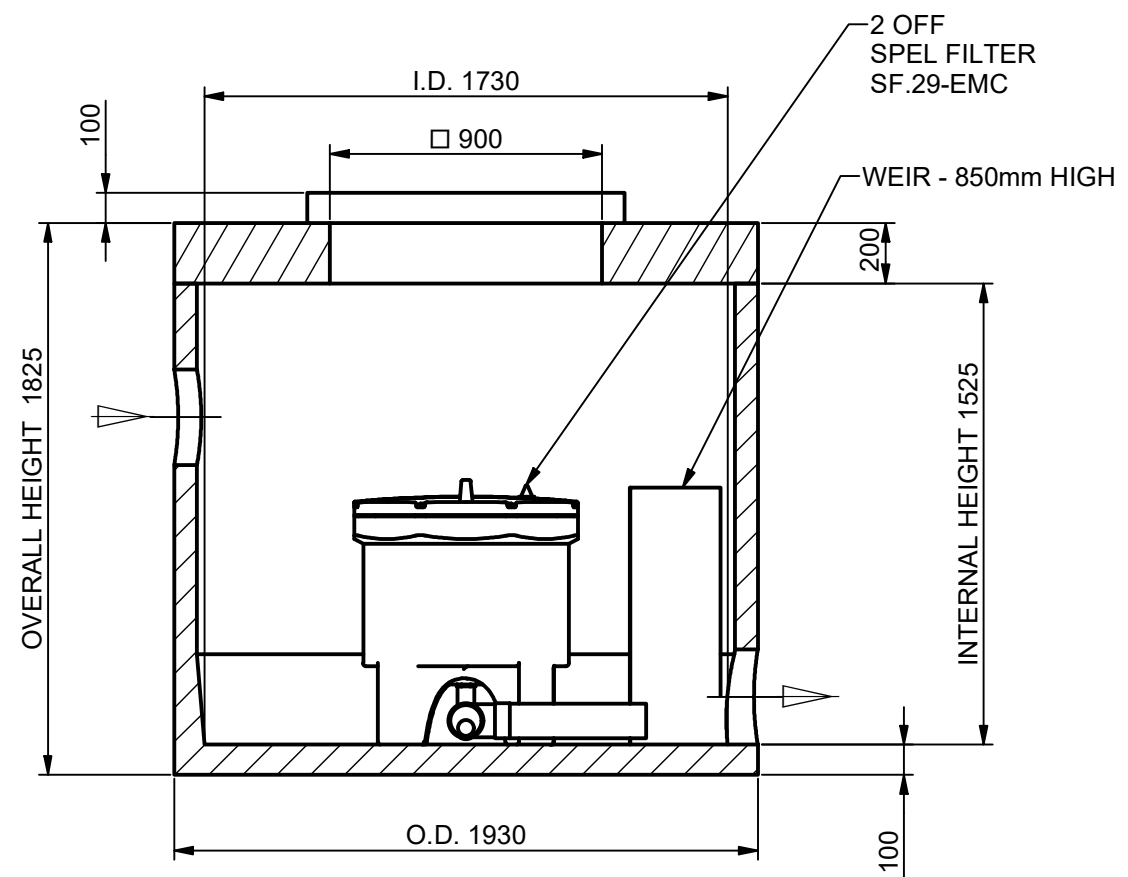

SECTION A-A

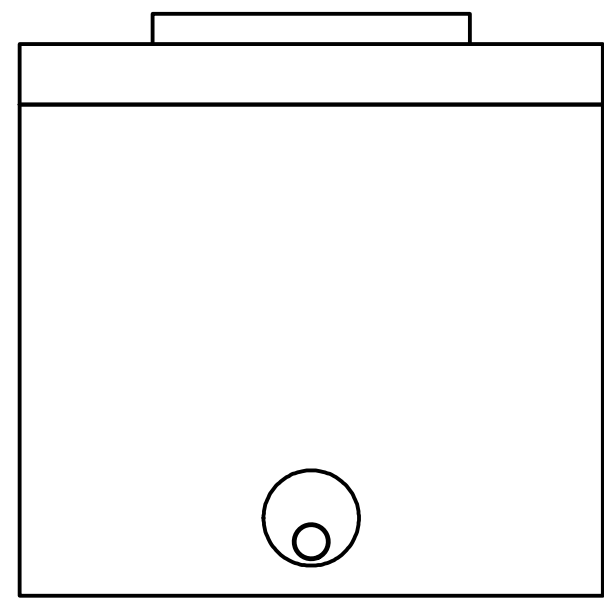

SIDE VIEW

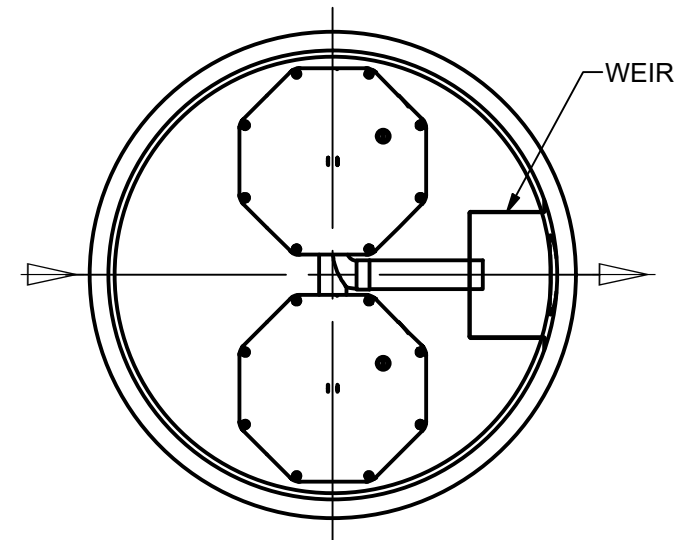

PLAN VIEW
COVER & LID REMOVED FOR CLARITY

TOLERANCE: ALL DIMENSIONS 10mm UNLESS OTHERWISE STATED.

CLIENT:

DISTRIBUTOR :

CONFIDENTIAL - The drawings must not be disclosed to any third parties without written permission from SPEL Environmental Sydney. Unauthorised disclosure may result in prosecution.
© SPEL Environmental - This drawing is the property of SPEL Environmental ABN: 83 151 832 629 and is subject to return on demand. It is submitted for the use only in connection with the proposal and contracts of SPEL Environmental with the expressed conditions that it is not to be reproduced or copied in any form. This data must only be used in accordance with our standard terms and conditions.
© Copyright
SPEL Environmental accepts no responsibility for any loss or damage resulting from any person acting on this information. The details and dimensions contained in this document may change, please check with SPEL Environmental for confirmation of current specifications.

Drawn	Date
P.Z.	4/06/2020
Check	Date
Verified	Date
Approved	Date
Request No.	

SPEL
STORMWATER

100 Silverwater Road Silverwater NSW 2128
PH: 1300 773 500 | E: sales@spel.com.au
www.spel.com.au

PROJECT : SPEL 3.7KL RECTANGLE TANK & FILTER FITOUT			
TITLE SPEL PRECAST TANK 3.7 KL CLASS D SF.173D/02-29.CON 2 SPEL FILTER CARTRIDGES			
SCALE N.T.S	SIZE A3	SHEET 1	REV 1
CUSTOMER CODE :		DWG No. SP20-SF16480-P	

E:\Vault\Working\Folders\Designs\SPEL\PRODUCTS\FILTER\BMC-45\STANDARD\02\FILTERS\CONCRETE\PROJECTS\SPEL PRECAST T44 TANK 3.7 KL NEW FILTERS\SP20-SF16480-P.dwg

Site Exit & Clean Up

At the end of the scheduled maintenance, approved contractors or SPEL maintenance crew are required to reinstate the site to pre-existing conditions. Steps included but limited to are:

- Ensure all access covers are securely inserted back into their frames;
- Remove and dispose collected pollutants from the site in accordance with local regulator authorities;
- Retrieve all traffic control measures and maintenance tools; and
- Return all exhausted and/or damaged SPEL products to SPEL Stormwater to begin recycling program.





spelstormwater
joy in water

100 Silverwater Rd, Silverwater NSW 2128 Australia

Phone: (02) 8705 0255

Fax: (02) 8014 8699

Email: sales@spel.com.au

spel.com.au

SPEL Stormwater accepts no responsibility for any loss or damage resulting from any person acting on this information. The details and dimensions contained in this document may change, please check with SPEL Stormwater for confirmation of current specifications.

Appendix G - OceanProtect Filter Operation and Maintenance Manual



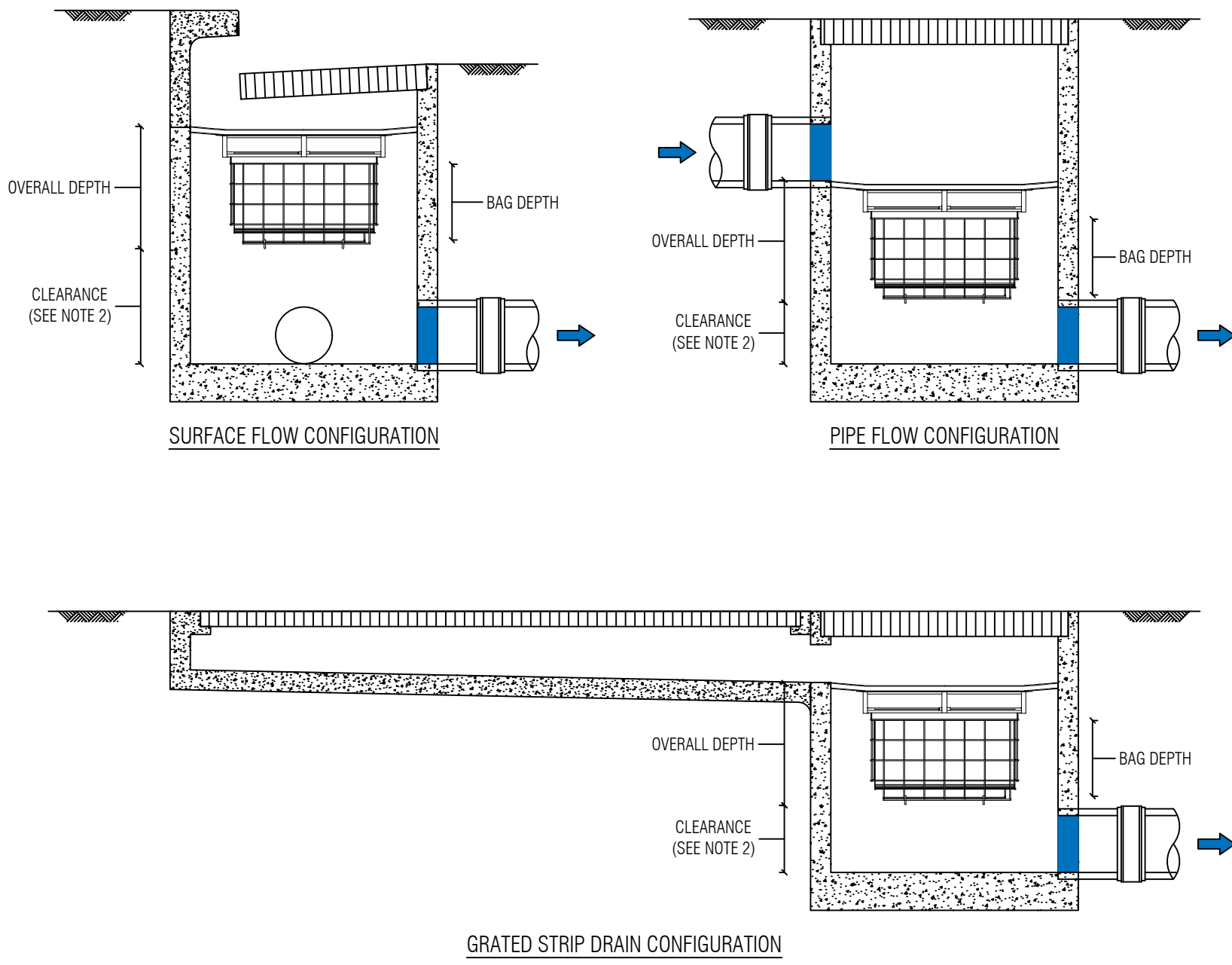

PLAN ID	MAXIMUM PIT PLAN DIMENSIONS
S	450mm x 450mm
M	600mm x 600mm
L	900mm x 900mm
XL	1200mm x 1200mm

DEPTH ID	BAG DEPTH	OVERALL DEPTH
1	170	270
2	300	450
3	600	700

		DEPTH ID		
		1	2	3
PLAN ID	S	■	■	■
	M	■	■	■
	L	■	■	■
	XL	■	■	■

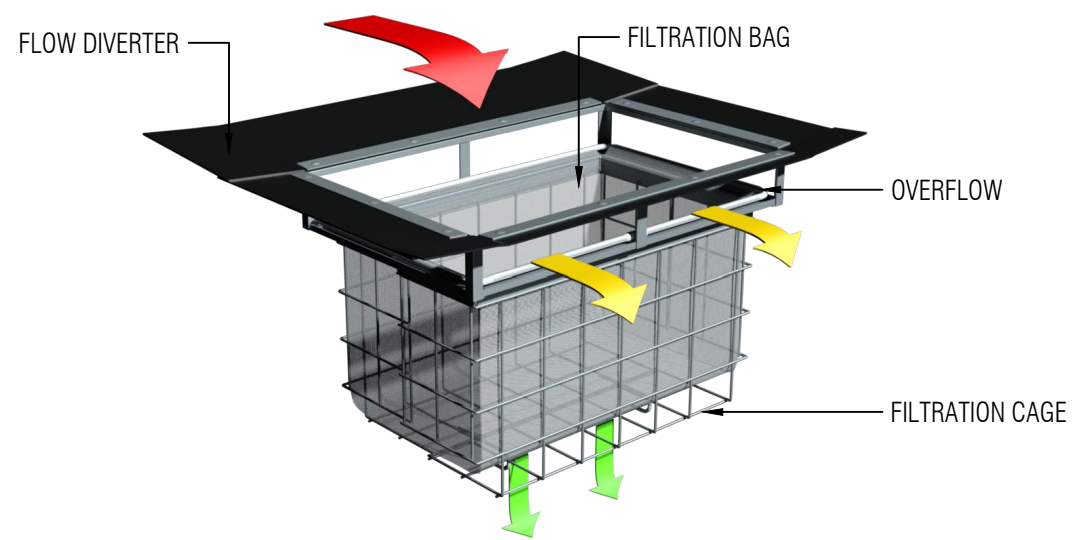

GENERAL NOTES

1. THE MINIMUM CLEARANCE DEPENDS ON THE CONFIGURATION (SEE NOTE 2) AND THE LOCAL COUNCIL REQUIREMENTS.
2. CLEARANCE FOR ANY PIT WITHOUT AN INLET PIPE (ONLY USED FOR SURFACE FLOW) CAN BE AS LOW AS 50mm. FOR OTHER PITS, THE RECOMMENDED CLEARANCE SHOULD BE GREATER OR EQUAL TO THE PIPE OBVERT SO AS NOT TO INHIBIT HYDRAULIC CAPACITY.
3. OCEAN PROTECT PROVIDES TWO FILTRATION BAG TYPES:- 200 MICRON BAGS FOR HIGHER WATER QUALITY FILTERING AND A COARSE BAG FOR TARGETING GROSS POLLUTANTS.
4. DRAWINGS NOT TO SCALE.



PHONE: 1300 354 722 www.oceanprotect.com.au

OCEAN PROTECT
OCEANGUARD
TYPICAL ARRANGEMENTS
SPECIFICATION DRAWING

N
O
N
S
T
R
U
C
T
I
O
N

F
O
R

C
O
N
S
T
R
U
C
T
I
O
N

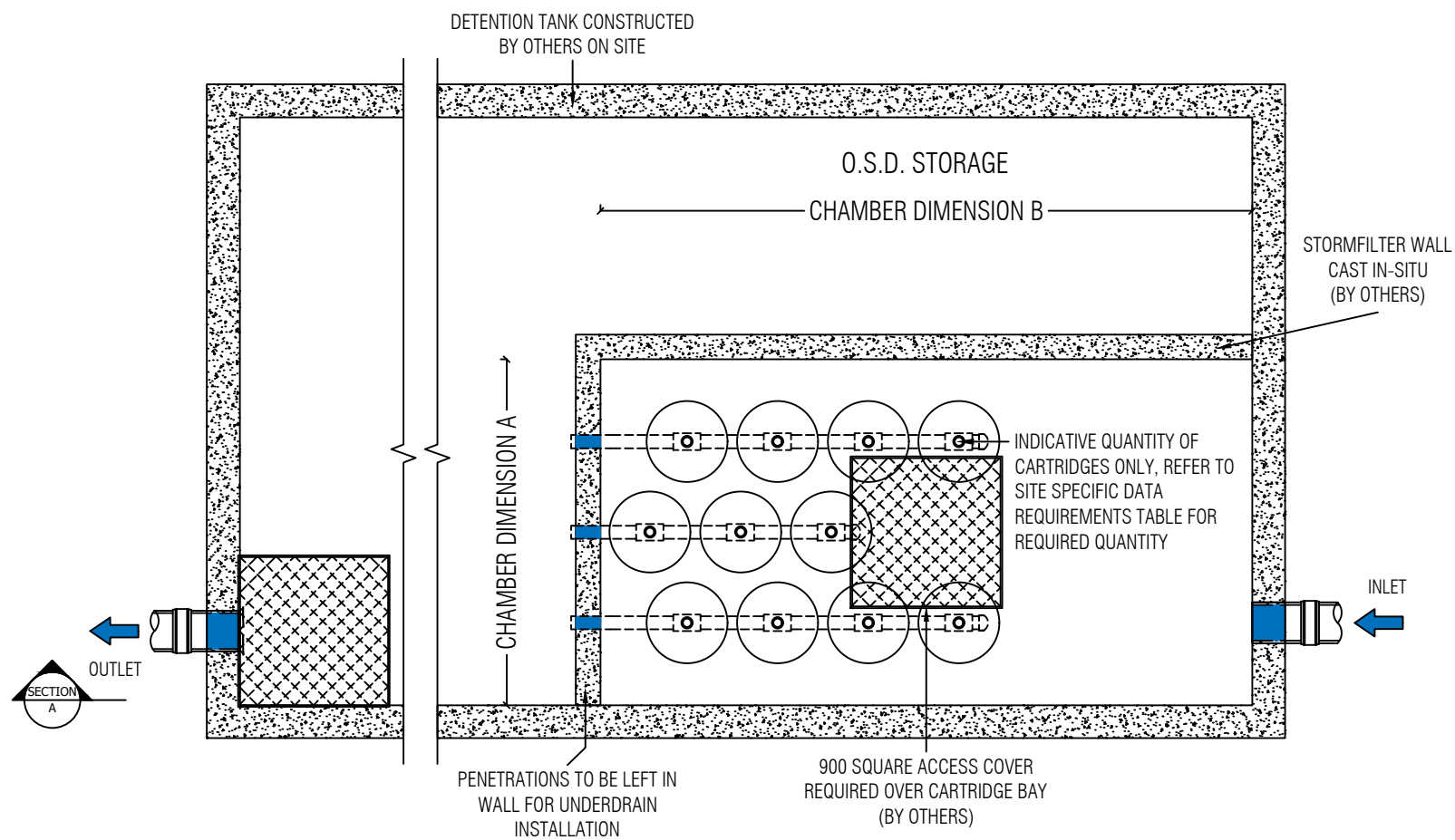

PLAN LAYOUT

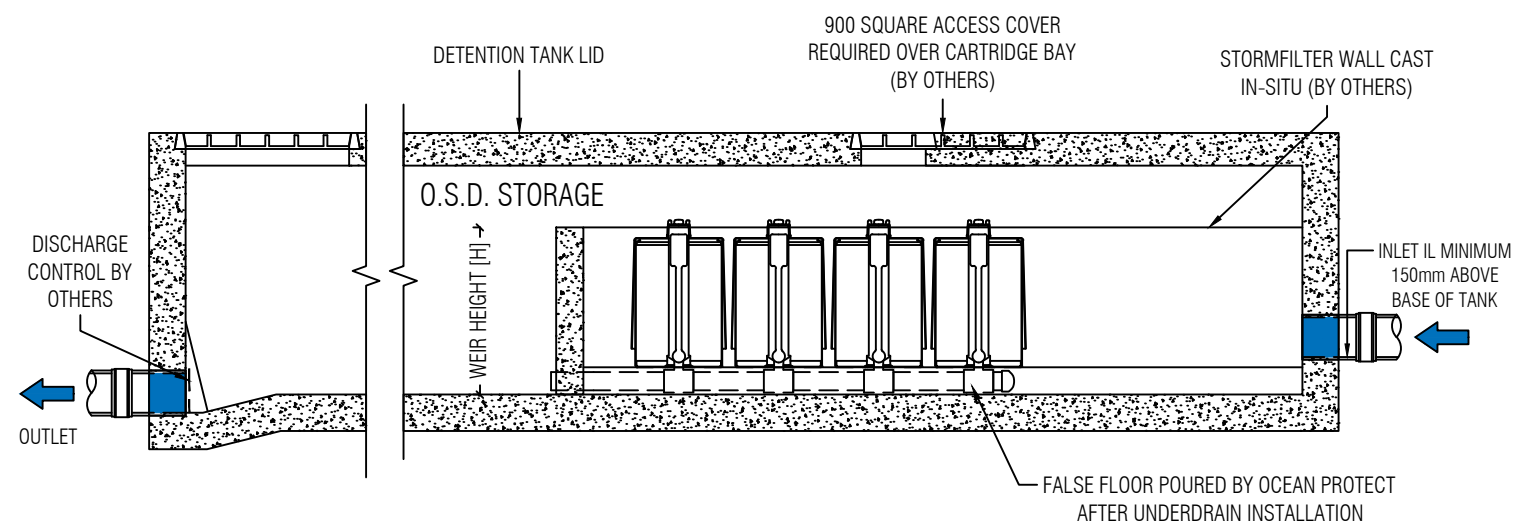

SECTION A

STORMFILTER DESIGN TABLE

- STORMFILTER TREATMENT CAPACITY VARIES BY NUMBER OF FILTER CARTRIDGES INSTALLED.
- THE STANDARD CONFIGURATION IS SHOWN. ACTUAL CONFIGURATION OF THE SPECIFIED STRUCTURE(S) PER CERTIFYING ENGINEER WILL BE SHOWN ON SUBMITTAL DRAWING(S).
- FILTER CARTRIDGES SHALL BE MEDIA-FILLED, PASSIVE, SIPHON ACTUATED, RADIAL FLOW, AND SELF-CLEANING. RADIAL MEDIA DEPTH SHALL BE 178mm.

CARTRIDGE NAME / SIPHON HEIGHT (mm)	690	460	310
CARTRIDGE PHYSICAL HEIGHT (mm)	840	600	600
TYPICAL WEIR HEIGHT [H] (mm)	920	690	540
CARTRIDGE FLOW RATE FOR ZPG MEDIA (L/s)	1.6	1.1	0.7
CARTRIDGE FLOW RATE FOR PSORB MEDIA (L/s)	0.9	0.46	0.39

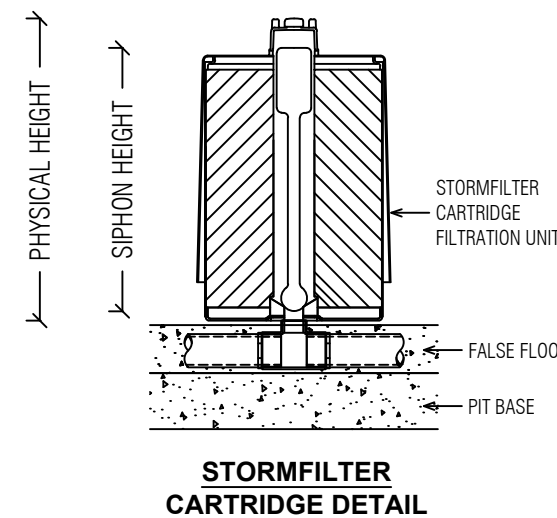

STORMFILTER CARTRIDGE DETAIL

SITE SPECIFIC DATA REQUIREMENTS

STRUCTURE ID	[]
NUMBER OF CARTRIDGES REQ'D	[]
SIPHON HEIGHT (310 / 460 / 690)	[]
MEDIA TYPE (ZPG / PSORB)	[]
WATER QUALITY FLOW RATE (L/S)	[]
DIMENSION A	[]
DIMENSION B	[]

TOTAL CARTRIDGE BAY AREA (A x B)
TO MATCH AREA REQUIRED BY MUSIC
MODELLING OR COUNCIL SPECIFIC
REQUIREMENTS

GENERAL NOTES

1. INLET AND OUTLET PIPES TO BE IN ACCORDANCE WITH APPROVED PLANS.
2. A HIGH FLOW BYPASS ARRANGEMENT OR DISSIPATION STRUCTURE MAY BE REQUIRED TO MINIMISE RE-SUSPENSION OF SOLIDS OR ANY SIGNIFICANT INERTIAL FORCES ON THE CARTRIDGES.
3. ALL WATER QUALITY TREATMENT DEVICES REQUIRE PERIODIC MAINTENANCE. REFER TO OPERATION AND MAINTENANCE MANUAL FOR GUIDELINES AND ACCESS REQUIREMENTS.
4. SITE SPECIFIC PRODUCTION DRAWING WILL BE PROVIDED ON PLACEMENT OF ORDER.
5. THE INVERT LEVEL OF THE INLET PIPE MUST BE GREATER THAN THE RL OF THE FALSE FLOOR WITHIN THE CARTRIDGE CHAMBER.
6. CONCRETE STRUCTURE AND ACCESS COVERS DESIGNED AND PROVIDED BY OTHERS. ACCESS COVERS TO BE A MINIMUM 900 X 900 ABOVE CARTRIDGES. OH&S REGARDING ACCESS COVERS AND TANK ACCESS TO BE ASSESSED BY OTHERS ON SITE.
7. THE STRUCTURE THICKNESSES SHOWN ARE FOR REPRESENTATIONAL PURPOSES.
8. DRAWINGS NOT TO SCALE.

INSTALLATION NOTES

1. UNDERDRAIN AND FALSE FLOOR INSTALLED BY OCEAN PROTECT.



PHONE: 1300 354 722

www.oceanprotect.com.au

OCEAN PROTECT
STORMFILTER SYSTEM
DETENTION TANK ARRANGEMENT
SPECIFICATION DRAWING

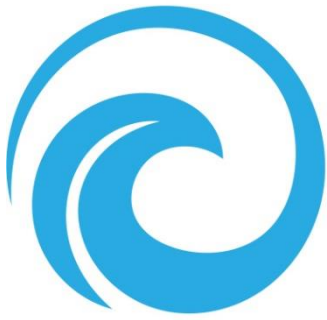

OCEAN
P R O T E C T

OceanGuard
Technical Design Guide

Table of Contents

Introduction.....	2
Operational Overview	2
Features.....	3
Configurations	3
Performance.....	4
Maintenance.....	4
Design Basics	5
1. Hydraulic Design & Configuration	5
2. Water Quality Design.....	5
3. Mass Load Design	5

Introduction

The OceanGuard technology is a gully pit basket designed to fit within new and existing stormwater pits targeting pollution in stormwater runoff. The system is offered with a choice of filtration bag liners, designed to remove gross pollutants, total suspended solids and attached pollutants. It can be adopted as a stand-alone technology or as part of a treatment train with our StormFilter or Jellyfish filtration products.

The filtration bag, filtration cage and flow diverter work together to maximise the flow treated, pollutant capture, hydraulic efficiency and ultimately retaining captured pollutants dry. OceanGuard pit inserts are highly effective, easy to install and simple to maintain.

Operational Overview

The OceanGuard is installed into field or kerb inlet gully pits. The flow diverter at top of the unit has a rigid recycled plastic HDPE skirt that is installed against the walls directing all incoming stormwater flows into the filtration bag.

The stormwater is then filtered via direct screening through the filtration bag liner ensuring that any debris larger than the openings in the filtration bag are captured and retained.

During large storm events the water elevation in the filtration bag can rise and peak flows are internally bypassed through slots created in the flow diverter which has no moving parts that may prematurely fail.

At the end of the storm event debris and stormwater rest at the base of the filtration bag where the stored material will start to dry until the next storm event.

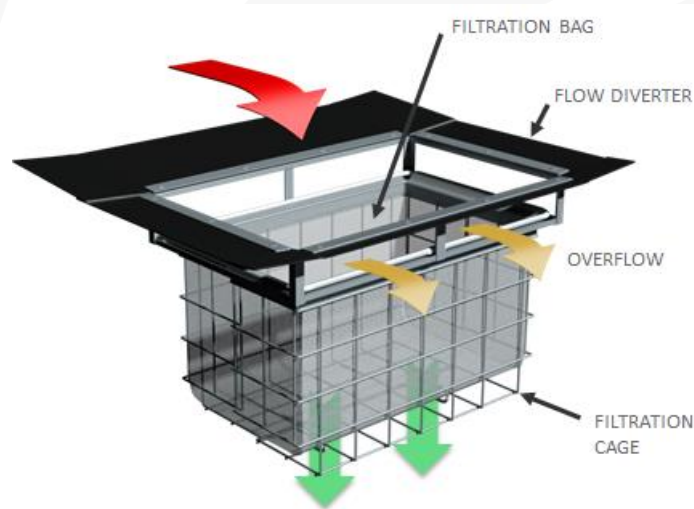

Figure 1: OceanGuard components

Features

The OceanGuard technology has the following features:

- Flow Diverter
Directs flow into the unit for filtration of stormwater flows and includes an in-built rigid bypass to divert stormwater overflows in high-intensity and peak storm flows.
- Filtration Bag
Removable coarse (gross pollutant removal) and fine grade (200micron) filtration bags.
- Filtration Cage
The supporting cage that allows for the use of larger filtration bags.

The OceanGuard can also be fitted with an oil/hydrocarbon adsorbent material (optional) to capture and retain oil and grease. The adsorbent material is contained in socks that are designed to ensure maximum contact with stormwater as it enters the gully pit.

The OceanGuard is designed to be easily retrofitted into new and existing stormwater pits, requiring no construction or land take. The OceanGuard is often the most practical solution and reduces the pollutant load and maintenance burden on downstream infrastructure.

Configurations

The OceanGuard can fit a range of pits typically found in Australia including, kerb entry, rear entry with grated drain entry as well as field gully pits. There are multiple sizes to suit pits ranging in plan dimensions of 450 x 450mm – 1200 x 1200mm. Additional custom sizes are available to suit circular and non-standard pits.

The standard OceanGuard configuration treats surface flow only, see figure 2. In some instances, it may be necessary to treat pipe flow, see figure 3. Remember to limit the upstream catchment to the basket to no more than 1000m² (or DN300mm pipe) otherwise the peak flows may cause structural damage to the OceanGuard. Furthermore, to assist design checks by a suitable qualified engineer need to be undertaken to ensure the upstream catchment is not excessively large. Please note that the OceanGuard technology is not a replacement for an in-line gross pollutant trap.

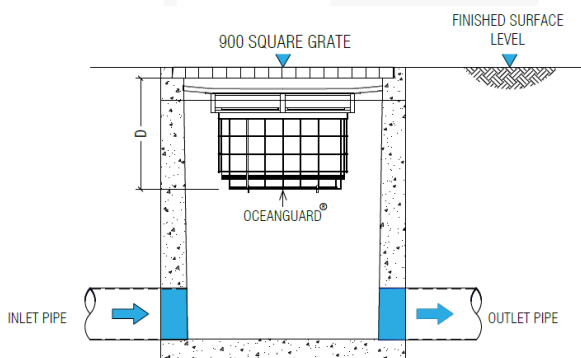

Figure 2: Standard configuration – surface flow

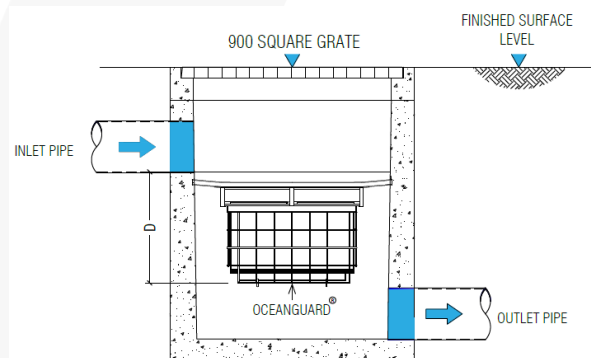

Figure 3: Example configuration – pipe flow

Another typical configuration required, is where the runoff collected by grated strip or trench drains needs to be treated, see figure 4.

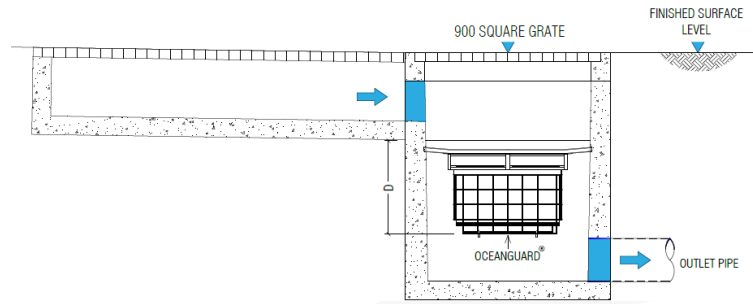

Figure 4: Example configuration – Grated strip/trench drain

Performance

Typically, laboratory testing provides a means to generate hydraulic and basic performance data, but it should also be complemented with long-term field data. Gully pit baskets that operate under unrestricted flows require both a combination lab and field studies to accurately understand performance.

Ocean Protect has and is undertaking field testing locally in Australia and copies of the supporting articles are available upon request from Ocean Protect.

Gully pit baskets and associated technology have been available in Australia and overseas for more than 20 years. The OceanGuard technology has design elements and removal performance that are the same as some off-patent technologies, such as the previous generation EnviroPod previously sold by Stormwater360 Australia (Now Ocean Protect) under licence.

The OceanGuard meets all previous performance data and current approvals across Australia in terms of pollutant removal, flow rate and head loss. Please contact your Ocean Protect representative for more information.

Please contact your Ocean Protect representative to obtain the StormFilter approval status in your area.

Maintenance

Maintenance of the OceanGuard is simple effective and seldom requires confined space entry or specialised equipment, often being completed by hand without the need of vacuum equipment. Simply remove the OceanGuard from the pit with the tags provided and invert the bag into a waste bin. Inspect the liner and brush by hand or spray with a pressure washer if required to rejuvenate the filtration bag. Record the information and replace the filtration bag.

Inspection & Cleaning

The Ocean Guard® system should be inspected at regular intervals from 1-2 months during the first year of installation to ensure optimum performance. The frequency at which the OceanGuard will need to be maintained will depend on site activities, land uses, catchment area and this size of OceanGuard installed, 1-6 times annually (3-4 typ.).

For further information please refer to the OceanGuard Operations and Maintenance Manual.

Design Basics

The design requirements of any OceanGuard system is detailed in 3 typical steps.

1. Hydraulic Design & Configuration
2. Water Quality Design
3. Mass Load Design

1. Hydraulic Design & Configuration

All OceanGuard inserts must be designed to ensure that the hydraulic requirements of the system are met without adversely impacting the upstream hydraulics (limiting the likelihood of localised flooding).

2. Water Quality Design

Ocean Protect recommends and uses the widely endorsed Model for Urban Stormwater Improvement Conceptualisation (MUSIC), which makes it easy to correctly sizing an appropriate StormFilter system for your site.

A complimentary design service which includes MUSIC modelling is provided by the Ocean Protect engineering team. Simply email your project details to design@oceanprotect.com.au or alternatively you can always call one of our engineers for a discussion or to arrange a meeting in your office. The team will provide you with an efficient design containing details of the devices required to meet your water quality objectives together with budget estimates, product drawings and the MUSIC (.sqz) file.

Alternatively, you can download the MUSIC treatment nodes for the Ocean Protect products from our website (www.oceanprotect.com.au).

When designing/modelling an OceanGuard system for water quality purposes in MUSIC, a single GPT node is utilised. The GPT node is utilised with relevant removal efficiencies inserted. These parameters can vary based on the jurisdiction (authority) of your project, relevant details can be obtained from Ocean Protect. When modelling, the high-flow bypass is modified in node by adding the total number of Ocean Guards installed and multiplying this number by 20L/s, eg 10 x Ocean Guards = 0.2m³/s.

All details such as drawings, specifications and maintenance manuals can also be downloaded for integration into your project's documentation. Additionally the Ocean Protect team is available to review your model and provide additional assistance and guidance on the configuration of the OceanGuard system(s) for your project.

3. Mass Load Design

Always be mindful of the magnitude of upstream catchment areas pay particular attention to perceived dirty or high loading sites. The Ocean Protect team can provide assistance and details on this process.



OceanGuard
Installation Guide

Rev: 1 Last Updated: March 2019

Introduction

The purpose of this manual is to indicate the safest and most efficient method in installing the Ocean Protect OceanGuard.

Equipment

The following personal protective equipment is required by staff for installation activities:

- Puncture resistant gloves
- Steel capped safety boots,
- Long sleeve clothing, overalls or similar skin protection
- Eye protection
- Hearing protection
- High visibility clothing or vest

Note: The above list is a guide only, all individuals performing installation should evaluate their own OH&S requirements as required by law or site specific safety requirements.

Typical tools required for installation include the following

- Tape measure
- Marking Template
- Marking spray paint
- 8mm masonry drill
- 5 mm steel drill
- Pop Riveter for 4.8mm rivets
- Hammer
- Stanley knife
- Straight edge
- 10mm socket and ratchet
- Hacksaw

Components

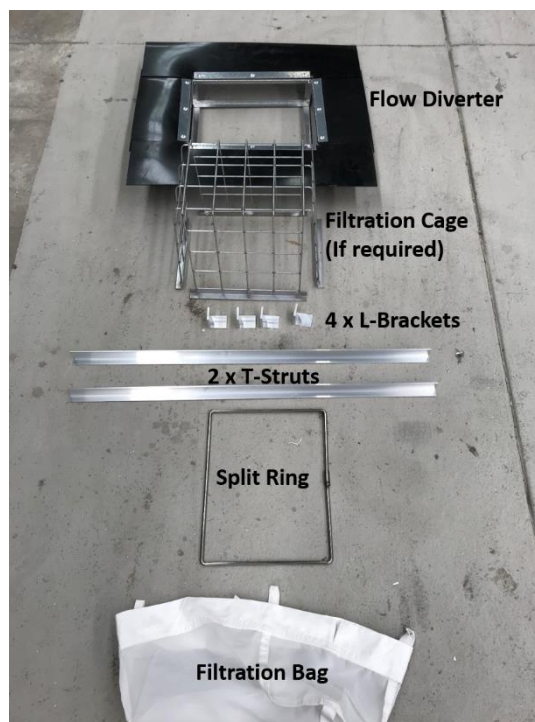

Figure 1: OceanGuard components

Configurations

The OceanGuard can fit a range of pits typically found in Australia including, kerb entry, rear entry with grated drain entry as well as field gully pits.

There are multiple sizes to suit pits ranging in plan dimensions of 450 x 450mm – 1200 x 1200mm. Additional custom sizes are available to suit circular and non-standard pits.

The standard OceanGuard installation treats surface flow only, see figure 2.

In some instances, it may be necessary to perform an installation that treats pipe flow, see figure 3.

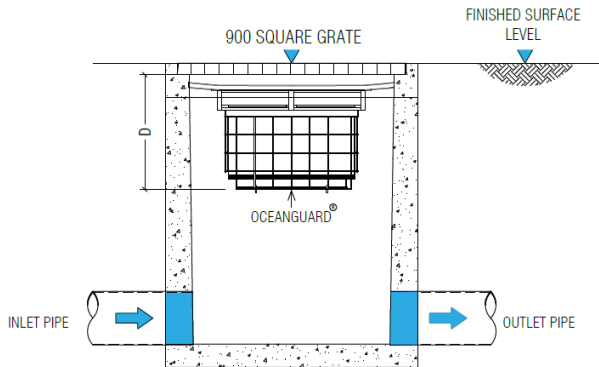

Figure 2: Standard configuration – surface flow

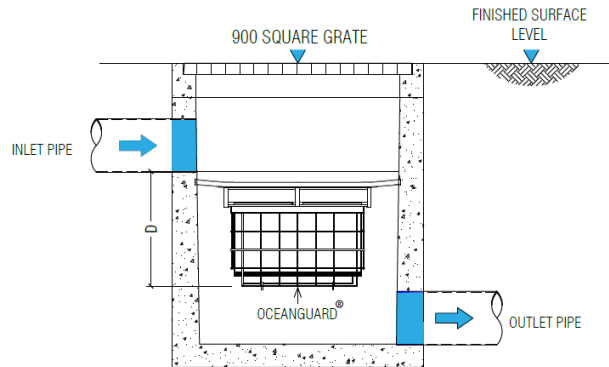

Figure 3: Example configuration – pipe flow

Another typical configuration required, is where the runoff collected by grated strip or trench drains needs to be treated, see figure 4.

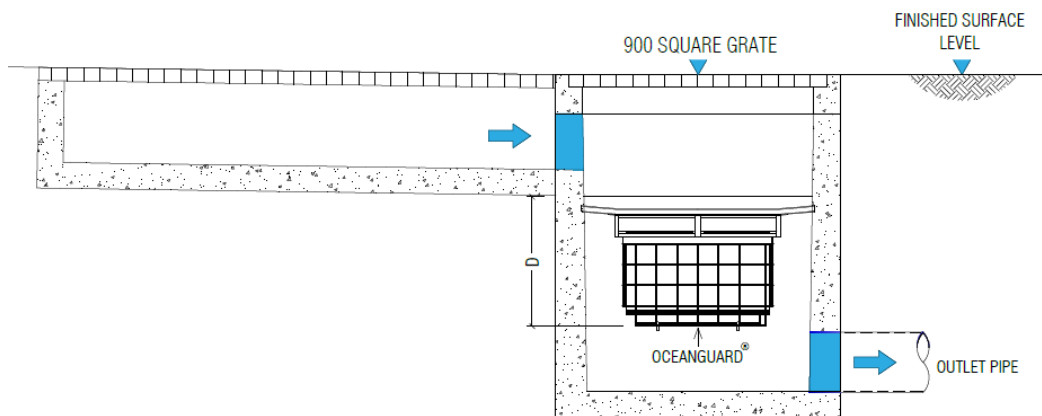

Figure 4: Example configuration – strip/trench drain

Installation Procedure

The aim of all pit insert installations is to install the largest unit into each pit, without influencing the hydraulic performance of the pit or drainage system.

Strut Install

1. Measure the internal dimensions of the pit while marking the center of the pit length, at 150mm down from entry of pit (the height where the struts are to be secured).



2. Mark the position of the holes for the L-brackets, based on the center mark
3. Using an 8mm masonry drill bit drill holes for the insertion of the Dyna Bolts (4 holes total, 2 per strut)



4. Attached L-brackets with dyna bolts to the pit wall (4 locations)



5. Align T-strut onto L-brackets and secure with pop rivets, repeat for second strut



Flow Diverter Install

1. Measure the internal dimensions of the pit at the height at which the plastic is to sit. If necessary trim flow diverter panels to fit internal dimensions (add an additional 20mm each side to ensure tight pressure fit)



2. With the plastic bent slightly upwards, lower the Top Section into the pit, guiding the unit so that it locates on the T Sections struts.



3. Drill a 5mm hole through the flow diverter and into the strut for each T-strut, and secure the flow diverter to the T-strut with a pop rivet. **NOTE: if you OceanGuard requires a Filtration Cage this step can be skipped and addressed as part of the Filtration Cage Installation.**

Filtration Cage Install (if required)

1. Lower the filtration cage through the flow diverter until the lip of the cage sits on the internal lip



2. Drill a 5mm hole through the flow diverter, filtration cage lip and into the strut for each T-strut, and secure the flow diverter to the T-strut with a pop rivet.

Filtration Bag Install

1. Open the split ring by pulling apart at the connection point and thread the filtration bag onto the stainless steel split ring.



2. Lower the bag into the pit ensuring and pull the internal filter mesh downwards to ensure a secure fit with the top section.





OCEAN
P R O T E C T

OceanGuard™

Operations & Maintenance Manual

Table of Contents

Introduction	2
Why do I need to perform maintenance?	2
Health and Safety	3
Personnel health and safety	3
How does it Work?	4
Maintenance Procedures	4
Primary Types of Maintenance	4
Minor Service	5
Hand Maintenance	5
Vacuum Maintenance	5
Major Service (Filter Bag Replacement)	5
Additional Reasons of Maintenance	6
Hazardous Material Spill	6
Blockages	6
Major Storms and Flooding	6
Disposal of Waste Materials	6
Maintenance Services	6

Introduction

The primary purpose of stormwater treatment devices is to capture and prevent pollutants from entering waterways, maintenance is a critical component of ensuring the ongoing effectiveness of this process. The specific requirements and frequency for maintenance depends on the treatment device and pollutant load characteristics of each site. This manual has been designed to provide details on the cleaning and maintenance processes as recommended by the manufacturer.

The OceanGuard technology is a gully pit basket designed to fit within new and existing gully pits to remove pollution from stormwater runoff. The system has a choice of Filtration liners, designed to remove gross pollutants, total suspended solids and attached pollutants as either a standalone technology or as part of a treatment train with our StormFilter or Jellyfish Filtration products. OceanGuard pit baskets are highly effective, easy to install and simple to maintain.

Why do I need to perform maintenance?

Adhering to the maintenance schedule of each stormwater treatment device is essential to ensuring that it functions properly throughout its design life.

During each inspection and clean, details of the mass, volume and type of material that has been collected by the device should be recorded. This data will assist with the revision of future management plans and help determine maintenance interval frequency. It is also essential that qualified and experienced personnel carry out all maintenance (including inspections, recording and reporting) in a systematic manner.

Maintenance of your stormwater management system is essential to ensuring ongoing at-source control of stormwater pollution. Maintenance also helps prevent structural failures (e.g. prevents blocked outlets) and aesthetic failures (e.g. debris build up), but most of all ensures the long term effective operation of the OceanGuard.

Health and Safety

Access to pits containing an OceanGuard typically requires removing (heavy) access covers/grates, but typically it is not necessary to enter into a confined space. Pollutants collected by the OceanGuard will vary depending on the nature of your site. There is potential for these materials to be harmful. For example, sediments may contain heavy metals, carcinogenic substances or sharp objects such as broken glass and syringes. For these reasons, there should be no primary contact with the waste collect and all aspects of maintaining and cleaning your OceanGuard require careful adherence to Occupational Health and Safety (OH&S) guidelines.

It is important to note that the same level of care needs to be taken to ensure the safety of non-work personnel, as a result it may be necessary to employ traffic/pedestrian control measures when the device is situated in, or near areas with high vehicular/pedestrian activity.

Personnel health and safety

Whilst performing maintenance on the OceanGuard pit insert, precautions should be taken in order to minimise (or when possible prevent) contact with sediment and other captured pollutants by maintenance personnel. In order to achieve this the following personal protective equipment (PPE) is recommended:

- Puncture resistant gloves
- Steel capped safety boots,
- Long sleeve clothing, overalls or similar skin protection
- Eye protection
- High visibility clothing or vest

During maintenance activities it may be necessary to implement traffic control measures. Ocean Protect recommend that a separate site specific traffic control plan is implemented as required to meet the relevant governing authority guidelines.

The OceanGuard pit insert is designed to be maintained from surface level, without the need to enter the pit. However depending on the installation configuration, location and site specific maintenance requirements it may be necessary to enter a confined space occasionally. It is recommended that all maintenance personnel evaluate their own needs for confined space entry and compliance with relevant industry regulations and guidelines. Ocean Protect maintenance personnel are fully trained and carry certification for confined space entry.

How does it Work?

OceanGuard is designed to intercept stormwater as it enters the stormwater pits throughout a site. The OceanGuard has diversion panels that sit flush with the pit walls, this ensures that as stormwater enters at the top of the pit it is directed to the middle of the insert where the Filtration bag is situated. The filtration bag allows for screening to occur removing 100% of pollutants greater than the opening of the filtration material (200micron, 1600micron bags available).

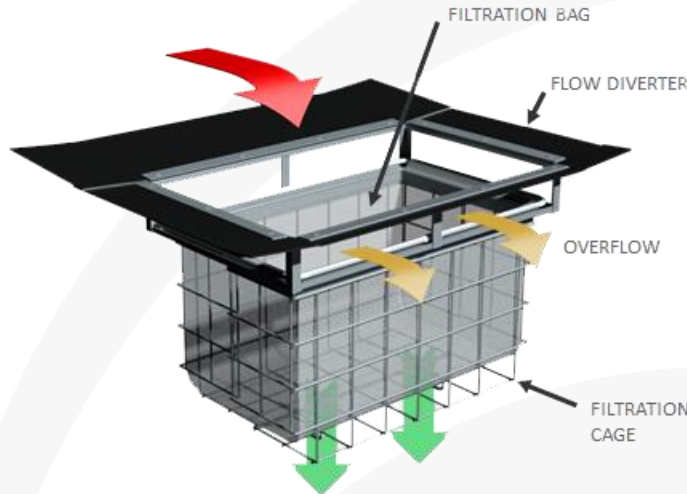

During larger rain events the large flows overflow slots in the flow diverter of the OceanGuard ensure that the conveyance of stormwater is not impeded thus eliminating the potential for surface flooding. As the flow subsides, the captured pollutants are held in the OceanGuard Filtration bag dry. The waste then starts to dry which reduces the magnitude of organic material decomposition transitioning between maintenance intervals.

Maintenance Procedures

To ensure that each OceanGuard pit insert achieves optimal performance, it is advisable that regular maintenance is performed. Typically the OceanGuard requires 2-4 minor services annually, pending the outcome of these inspections additional maintenance servicing may be required.

Primary Types of Maintenance

The table below outlines the primary types of maintenance activities that typically take place as part of an ongoing maintenance schedule for the OceanGuard.

	Description of Typical Activities	Frequency
Minor Service	Filter bag inspection and evaluation Removal of capture pollutants Disposal of material	2-4 Times Annually
Major Service	Filter Bag Replacement Support frame rectification	As required

Maintenance requirements and frequencies are dependent on the pollutant load characteristics of each site. The frequencies provided in this document represent what the manufacturer considers to be best practice to ensure the continuing operation of the device is in line with the original design specification.

Minor Service

This service is designed to return the OceanGuard device back to optimal operating performance. This type of service can be undertaken either by hand or with the assistance of a Vacuum unit.

Hand Maintenance

1. Establish a safe working area around the pit insert
2. Remove access cover/grate
3. Use two lifting hooks to remove the filtration bag
4. Empty the contents of the filtration bag into a disposal container
5. Inspect and evaluate the filtration bag
6. Inspect and evaluate remaining OceanGuard components (i.e. flow diverter, filtration cage and supporting frame)
7. Rejuvenate filtration bag by removing pollutant build up with a stiff brush, additionally the filtration bag can be washed using high pressure water
8. Re-install filtration bag and replace access cover/grate

Vacuum Maintenance

1. Establish a safe working area around the pit insert
2. Remove access cover/grate
3. Vacuum captured pollutants from the filtration bag
4. Remove filtration bag
5. Inspect and evaluate the filtration bag
6. Inspect and evaluate remaining OceanGuard components (i.e. flow diverter, filtration cage and supporting frame)
7. Rejuvenate filtration bag by removing pollutant build up with a stiff brush, additionally the filtration bag can be washed using high pressure water
8. Re-install filtration bag and replace access cover/grate

Major Service (Filter Bag Replacement)

For the OceanGuard system, a major service is a reactionary process based on the outcomes from the minor service.

Trigger Event from Minor Service	Maintenance Action
Filtration bag inspection reveals damage	Replace the filtration bag ^[1]
Component inspection reveals damage	Perform rectification works and if necessary replace components ^[1]

[1] Replacement filtration bags and components are available for purchase from Ocean Protect.

Additional Reasons of Maintenance

Occasionally, events on site can make it necessary to perform additional maintenance to ensure the continuing performance of the device.

Hazardous Material Spill

If there is a spill event on site, all OceanGuard pits that potentially received flow should be inspected and cleaned. Specifically all captured pollutants from within the filtration bag should be removed and disposed in accordance with any additional requirements that may relate to the type of spill event. All filtration bags should be rejuvenated (replaced if required) and re-installed.

Blockages

The OceanGuards internal high flow bypass functionality is designed to minimise the potential of blockages/flooding. In the unlikely event that flooding occurs around the stormwater pit the following steps should be undertaken to assist in diagnosing the issue and implementing the appropriate response.

1. Inspect the OceanGuard flow diverter, ensuring that they are free of debris and pollutants
2. Perform a minor service on the OceanGuard
3. Remove the OceanGuard insert to access the pit and inspect both the inlet and outlet pipes, ensuring they are free of debris and pollutants

Major Storms and Flooding

In addition to the scheduled activities, it is important to inspect the condition of the OceanGuard pit insert after a major storm event. The inspection should focus on checking for damage and higher than normal sediment accumulation that may result from localised erosion. Where necessary damaged components should be replaced and accumulated pollutants disposed.

Disposal of Waste Materials

The accumulated pollutants found in the OceanGuard must be handled and disposed of in a manner that is in accordance with all applicable waste disposal regulations. When scheduling maintenance, consideration must be made for the disposal of solid and liquid wastes. If the filtration bag has been contaminated with any unusual substance, there may be additional special handling and disposal methods required to comply with relevant government/authority/industry regulations.

Maintenance Services

With over a decade and a half of maintenance experience Ocean Protect has developed a systematic approach to inspecting, cleaning and maintaining a wide variety of stormwater treatment devices. Our fully trained and professional staff are familiar with the characteristics of each type of system, and the processes required to ensure its optimal performance.

Ocean Protect has several stormwater maintenance service options available to help ensure that your stormwater device functions properly throughout its design life. In the case of our OceanGuard system we offer long term pay-as-you-go contracts, pre-paid once off servicing and replacement filter bags.

For more information please visit www.OceanProtect.com.au



StormFilter

Technical Design Guide

Table of Contents

Introduction.....	2
Operational Overview	2
Features	3
Media Options	3
Cartridge Options	4
Configurations	5
Performance and Select Approvals	6
Maintenance.....	7
Design Basics	7
1. Hydraulic Design	7
2. Water Quality Design.....	8
3. Mass Load Design	8

Introduction

The Ocean Protect StormFilter® is an underground stormwater treatment device comprised of one or more structures that house rechargeable, media-filled cartridges that trap particulates and adsorb pollutants from stormwater runoff such as total suspended solids, hydrocarbons, nutrients, metals, and other common pollutants.

With media options to target multiple or specific pollutants, multiple system configurations, and field and laboratory performance verified by the most stringent stormwater technology evaluation organisations, the StormFilter provides engineers with the most flexible and reliable manufactured treatment technology available.

Operational Overview

During a storm, runoff percolates through the filtration media and starts filling the cartridge central tube. The air inside the hood is purged through a one-way check valve as the water rises. When water reaches the top of the float, buoyant forces pull the float free and allow filtered water to exit the cartridge.

A siphon is established within each cartridge that draws water uniformly across the full height of the media profile ensuring even distribution of pollutants and prolonged media longevity.

As the storm subsides and the water level in the structure starts falling, a hanging water column remains under the cartridge hood until the water level reaches the scrubbing regulators at the bottom of the hood. Air then rushes through the regulators breaking the siphon and creating air bubbles that agitate the surface of the filter media causing accumulated sediment to settle on the treatment bay floor. This unique surface-cleaning mechanism helps prevent surface blinding and further extends cartridge life.

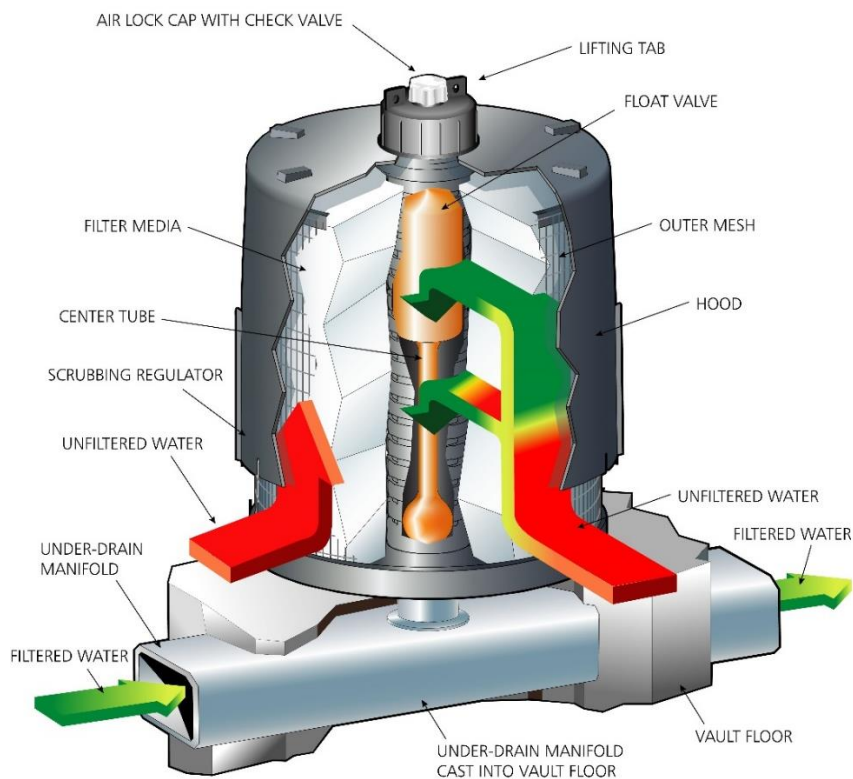

Figure 1: StormFilter cartridge components

Features

Media Options

The StormFilter system has the ability to operate with a variety of media options. These options are designed to target site or regulatory specific requirements. The current range of options is as follows:

- PhosphoSorb™
- ZPG™
- Perlite

PhosphoSorb™ (PSorb) media is the most advanced option available and is suited to most applications. Produced locally in Australia by Ocean Protect, PSorb achieves the optimum combination of pollutant removal and cost-effective treatment.

PSorb is a lightweight Perlite-based media coated in activated alumina. It removes Total Suspended Solids and Nutrients including some soluble forms of both Nitrogen and Phosphorus. PSorb media was developed to improve not only performance but also to provide a longer service life and to reduce OH&S risk by drastically reducing cartridge weight.

The other primary media option utilised by Ocean Protect is our ZPG™ media. It consists of Perlite, Zeolite and Granular Activated Carbon and was Ocean Protects original regulatory approved media for treating Total Suspended Solids and Nutrients.

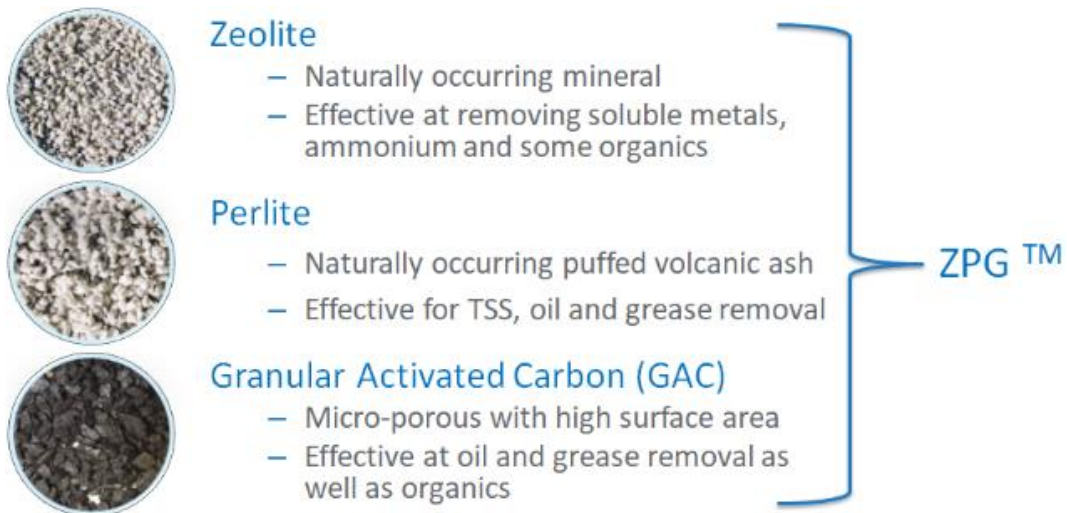

Figure 2: ZPG Media Overview

Cartridge Options

The StormFilter cartridge is available in three size options 310, 460 and 690 (Refer Table 1). The 690 StormFilter cartridge delivers most cost effective solution within these options. It has the highest flow rate and the largest filtration surface area and sediment capacity, however it requires a greater head loss and physical height to achieve this. In comparison the 460 and 310 cartridge options are best utilised when either physical height or head loss are a limiting factor.

The physical height of the cartridge must not be confused with the cartridge naming convention. Refer to table 1 for the physical cartridge height when needing to utilise the StormFilter cartridges in a shallow height unit.

The flow rate through each cartridge media option is controlled by a flow restrictor disc (orifice) that is located at the base of each cartridge. Reducing the flow rate across the uniform media depth increases pollutant removal and the Mass Load Capacity of each cartridge.

Cartridge Name / Siphon Height (mm)	690	460	310
Physical Height (H) mm	840	600	600
Typical Weir Height from outlet (Head Loss, mm)	920	690	540
Flow Rate ZPG (L/s)	1.60	1.10	0.70
Flow Rate PSorb (L/s)	0.90	0.46	0.39

Table 1: StormFilter cartridge details

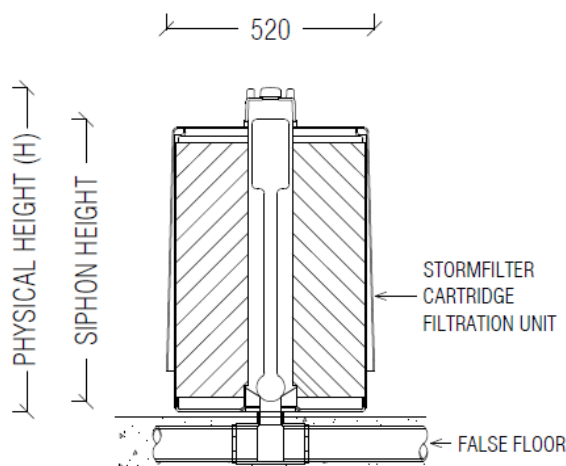

Figure 3: StormFilter cartridge dimensions

Configurations

The StormFilter cartridge system can be housed in a variety of ways such that it suits the site specific requirements for flowrate, hydraulics, accessibility and footprint restrictions. The standard configurations offered by Ocean Protect include pre-cast concrete tanks, detention and above ground pre-fabricated tanks.

Pre-cast concrete StormFilter systems can house the cartridges within manholes, pits or vaults. These systems are simple to install, as they arrive on site after being manufactured offsite to suit site specific requirements (pipe size, inlet/outlet orientation, levels etc.).



Figure 4: Pre-cast concrete manholes

Alternatively detention tanks constructed for water quantity requirements, can incorporate the StormFilter system into the design. Typically a separated water quality chamber (cartridge bay area) is constructed inside the larger tank. With this approach Ocean Protect performs the installation of the underdrain pipework manifold within the chamber, including the encasement of it in a concrete false floor.

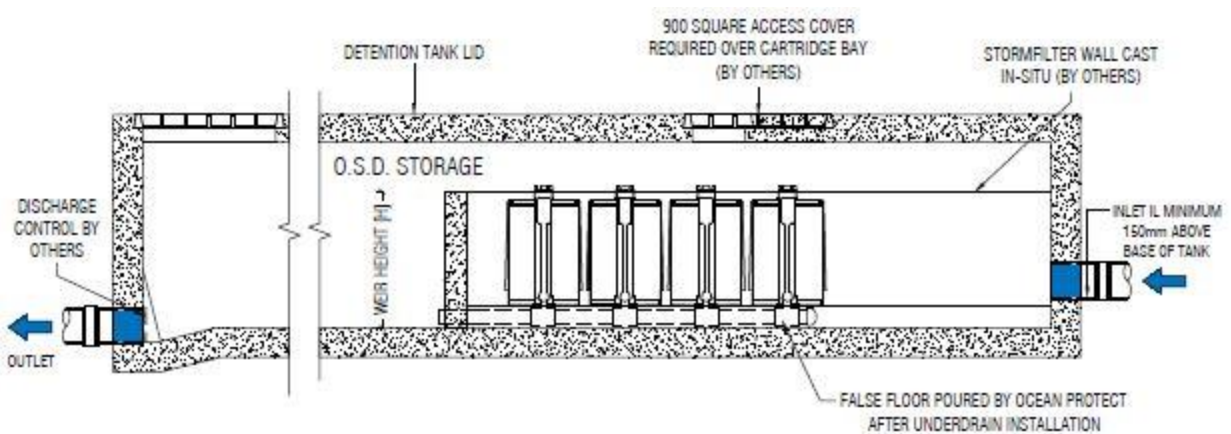

Figure 5: Detention system, sectional view

Above ground pre-fabricated tanks are also available, and are ideal for utilisation when treating downpipe flows. Often utilised when space is limited (boundary to boundary) they are available in both aluminium and HDPE and are custom built to suit the site specific requirements.



Figure 6: Aluminium StormFilter tank

Performance and Select Approvals

While laboratory testing provides a means to generate hydraulic and basic performance data, all filtration devices should also be complemented with long-term field data evaluations. As a minimum, field studies should generally comply with a recognised field testing protocol, for example, the Technology Acceptance Reciprocity Partnership (TARP) or the Technology Assessment Protocol – Ecology (TAPE) in the USA.

To be considered valid, all field monitoring programs should be peer reviewed by a reputable third party and replicate local pollutant concentrations including soluble fractions of nutrients together with rainfall. Ocean Protect has undertaken such field testing both locally in Australia and overseas, copies of the supporting articles are available upon request.

Globally there are over 220,000 StormFilter cartridges installed and since 2001 the StormFilter system has been successfully installed in a variety of applications to meet regulatory requirements set by authorities throughout Australia.

Specifically StormFilter has been accepted by some of the most stringent stormwater quality regulators around the globe including;

- Brisbane City Council
- Gold Coast City Council
- Blacktown City Council
- Washington State Department of Ecology (TAPE) GULD – Basic, Phosphorus
- New Jersey Department of Environmental Protection (NJ DEP)
- North Carolina Department of Environmental Quality (NC DEQ)
- Maine Department of Environmental Protection (ME DEP)

Please contact your Ocean Protect representative to obtain the StormFilter approval status in your area.

Maintenance

All stormwater quality improvement devices require routine maintenance. The question is how often and how much it will cost. Proper evaluation of long-term maintenance costs should be a consideration when selecting a treatment device. The StormFilter has been optimized to reduce long-term maintenance costs with proven, repeatable performance in the laboratory and in the field.

Reduce Life Cycle Costs

StormFilter has been designed for predictable maintenance intervals ranging from 1 to 3 years, resulting in fewer maintenance events and reduced life-cycle costs compared to other filtration devices.

Easy to maintain

All StormFilter structures provide access for inspection, media replacement, and washing of the structure. Visual indicators for maintenance are observable from the surface. Our Cartridge replacement program provides refurbished cartridges that are shipped to your site ready to install. Ocean Protect arranges for empty cartridges to be picked up and shipped back, reducing cartridge costs and environmental impact.

Maintenance support

Ocean Protect provides flexible options and contract terms. A detailed maintenance guide and mass load calculation spreadsheet is available upon request.

For further information please refer to the StormFilter Operations and Maintenance Manual ([click here](#)).

Design Basics

The design requirements of any StormFilter system is detailed in 3 typical steps.

1. Hydraulic Design
2. Water Quality Design
3. Mass Load Design

1. Hydraulic Design

All StormFilters must be designed to ensure that the hydraulic requirements of the system are met without adversely impacting the upstream hydraulics (limiting the likelihood of localised flooding). Table 1 (page 4) details the head loss for each cartridge size option. The designer must initially select a cartridge option and ensure the corresponding head loss can be catered for.

For a StormFilter system head loss does not have to equal head drop. If the head loss is not able to be fully achieved through a differential of height between the inlet and outlet pipes, then a minimum head drop of 100mm is required across the system with the balance of the head loss being impacted upstream. The minimum head drop is required to ensure that all inlet pipes enter the chamber above the concrete false floor.

StormFilter cartridges have a unique backflush mechanism that is passively activated at the end of each storm peak to increase the longevity of each cartridge. Consequently, captured pollutants are stored within the system and in order to minimise scour peak flows into the cartridge bay need to be limited. Specifically when peak flows surpass 80-100L/s StormFilter cartridges need to be arranged off-line.

It is also necessary to consider the impacts that tail water/submergence has on all stormwater treatment devices. In order to maintain an effective driving head for the StormFilter system the weir height should be adjusted accordingly. Please be aware that permanent submergence will blind all stormwater treatment devices utilising media. In the case of the StormFilter system, regardless of the storm intensity/duration the system will always drain relatively dry.

2. Water Quality Design

Ocean Protect recommends and uses the widely endorsed Model for Urban Stormwater Improvement Conceptualisation (MUSIC), which makes it easy to correctly sizing an appropriate StormFilter system for your site.

A complimentary design service which includes MUSIC modelling is provided by the Ocean Protect engineering team. Simply email your project details to design@oceanprotect.com.au or alternatively you can always call one of our engineers for a discussion or to arrange a meeting in your office. The team will provide you with an efficient design containing details of the devices required to meet your water quality objectives together with budget estimates, product drawings and the MUSIC (.sqz) file.

Alternatively, you can download the MUSIC treatment nodes for the Ocean Protect products from our website (www.oceanprotect.com.au).

When designing/modelling a StormFilter system for water quality purposes in MUSIC, two (2) treatment nodes are typically utilised in series. These are the detention/sedimentation node located immediately upstream of a generic treatment node.

For the detention node there are a number of parameters that need to be entered to ensure the node is representative of its effectiveness within the treatment train: surface area, extended detention depth, k-values, equivalent pipe diameter etc. For guidance on all of these variables please refer to the StormFilter design pack or contact Ocean Protect.

For the StormFilter system the generic treatment node is utilised with relevant removal efficiencies inserted. These parameters can vary based on the jurisdiction (authority) of your project, relevant details can be obtained from Ocean Protect. The high-flow bypass figure is adjusted within the node to represent the treatable flow rate required to obtain water quality targets. Once finalised this figure can be divided by the relevant cartridge flow rate to obtain the number of cartridges.

All details such as drawings, specifications and maintenance manuals can also be downloaded for integration into your project's documentation. Additionally the Ocean Protect team is available to review your model and provide additional assistance and guidance on the configuration of the StormFilter system(s) for your project.

3. Mass Load Design

At the completion of your water quality design process (as above) it is necessary that maintenance frequency is considered in order to prevent excessive ongoing maintenance requirements. Ocean Protect recommends a minimum maintenance frequency of 12 months.

All filtration devices occlude overtime, consequently they have a maximum sediment capacity (TSS load). By analysing the mean annual load figures for the StormFilter generic treatment node, the total annual retained TSS can be determined. To determine the minimum cartridge quantity required by mass load design, the annual retained TSS should be divided by the relevant cartridge sediment capacity. The Ocean Protect team can provide assistance and details on this process.

In determining the final cartridge quantity for your project, you must utilise the largest number of cartridges obtained from undertaking Water Quality and Mass Load design steps.



OCEAN
P R O T E C T

StormFilter

Operations & Maintenance Manual

Table of Contents

Introduction.....	2
Why do I need to perform maintenance?.....	2
Health and Safety	3
Personnel health and safety.....	3
How does it Work?	4
Maintenance Procedures	4
Primary Types of Maintenance.....	4
Inspection	5
Minor Service.....	5
Major Service (Filter Cartridge Replacement).....	5
Additional Types of Maintenance	6
Hazardous Material Spill.....	6
Blockages	6
Major Storms and Flooding	6
Disposal of Waste Materials.....	6
Maintenance Services.....	6

Introduction

The primary purpose of stormwater treatment devices is to capture and prevent pollutants from entering waterways, maintenance is a critical component of ensuring the ongoing effectiveness of this process. The specific requirements and frequency for maintenance depends on the treatment device and pollutant load characteristics of each site. This manual has been designed to provide details on the cleaning and maintenance processes for the StormFilter as recommended by the manufacturer.

The StormFilter is designed and sized to meet stringent regulatory requirements. It removes the most challenging target pollutants (including fine solids, soluble heavy metals, oil, and soluble nutrients) using a variety of media. For more than two decades, StormFilter has helped clients meet their regulatory needs and, through ongoing product enhancements, the design continues to be refined for ease of use and improved performance.

Why do I need to perform maintenance?

Adhering to the inspection and maintenance schedule of each stormwater treatment device is essential to ensuring that it functions properly throughout its design life.

During each inspection and clean, details of the mass, volume and type of material that has been collected by the device should be recorded. This data will assist with the revision of future management plans and help determine maintenance interval frequency. It is also essential that qualified and experienced personnel carry out all maintenance (including inspections, recording and reporting) in a systematic manner.

Maintenance of your stormwater management system is essential to ensuring ongoing at-source control of stormwater pollution. Maintenance also helps prevent structural failures (e.g. prevents blocked outlets) and aesthetic failures (e.g. debris build up), but most of all ensures the long term effective operation of the StormFilter.

Health and Safety

Access to a StormFilter unit requires removing heavy access covers/grates, and it is necessary to enter into a confined space. Pollutants collected by the StormFilter will vary depending on the nature of your site. There is potential for these materials to be harmful. For example, sediments may contain heavy metals, carcinogenic substances or objects such as broken glass and syringes. For these reasons, all aspects of maintaining and cleaning your StormFilter require careful adherence to Occupational Health and Safety (OH&S) guidelines.

It is important to note that the same level of care needs to be taken to ensure the safety of non-work personnel. As a result, it may be necessary to employ traffic/pedestrian control measures when the device is situated in, or near areas with high vehicular/pedestrian activity.

Personnel health and safety

Whilst performing maintenance on the StormFilter, precautions should be taken in order to minimise (or, if possible, prevent) contact with sediment and other captured pollutants by maintenance personnel. The following personal protective equipment (PPE) is subsequently recommended:

- Puncture resistant gloves
- Steel capped safety boots
- Long sleeve clothing, overalls or similar skin protection
- Eye protection
- High visibility clothing or vest

During maintenance activities, it may be necessary to implement traffic control measures. Ocean Protect recommend that a separate site-specific traffic control plan is implemented as required to meet the relevant governing authority guidelines.

Whilst some aspects of StormFilter maintenance can be performed from surface level, there will be a need to enter the StormFilter system (confined space) during a major service. It is recommended that all maintenance personnel evaluate their own needs for confined space entry and compliance with relevant industry regulations and guidelines. Ocean Protect maintenance personnel are fully trained and carry certification for confined space entry applications.

How does it Work?

Stormwater enters the cartridge chamber, passes through the filtration media and begins filling the cartridge center tube. When water reaches the top of the cartridge the float valve opens and filtered water is allowed to drain at the designed flow rate. Simultaneously, a one-way check valve closes activating a siphon that draws stormwater evenly throughout the filter media and into the center tube. Treated stormwater is then able to discharge out of the system through the underdrain manifold pipework.

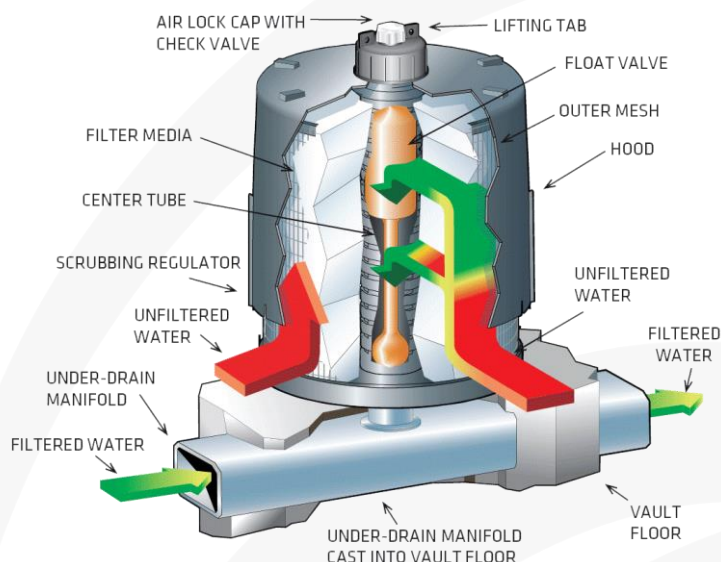

As the rain event subsides, the water level outside the cartridge drops and approaches the bottom of the hood, air rushes through the scrubbing regulators releasing the water column and breaking the siphon. The turbulent bubbling action agitates the surface of the cartridge promoting trapped sediment to drop to the chamber floor. After a rain event, the chamber is able to drain dry by way of an imperfect seal at the base of the float valve.

Maintenance Procedures

To ensure optimal performance, it is advisable that regular maintenance is performed. Typically, the StormFilter requires an inspection every 6 months with a minor service at 12 months. Additionally, as the StormFilter cartridges capture pollutants the media will eventually become occluded and require replacement (expected media life is 1-3 years).

Primary Types of Maintenance

The table below outlines the primary types of maintenance activities that typically take place as part of an ongoing maintenance schedule for the StormFilter.

	Description of Typical Activities	Frequency
Inspection	Visual Inspection of cartridges & chamber Remove larger gross pollutants Perform minimal rectification works (if required)	Every 6 Months
Minor Service	Evaluation of cartridges and media Removal of accumulated sediment (if required) Wash-down of StormFilter chamber (if required)	Every 12 Months
Major Service	Replacement of StormFilter cartridge media	As required

Maintenance requirements and frequencies are dependent on the pollutant load characteristics of each site. The frequencies provided in this document represent what the manufacturer considers to be best practice to ensure the continuing operation of the device is in line with the original design specification.

Inspection

The purpose of the inspecting the StormFilter system is to assess the condition of the StormFilter chamber and cartridges. When inspecting the chamber, particular attention should be taken to ensure all cartridges are firmly connected to the connectors. It is also an optimal opportunity to remove larger gross pollutants and inspect the outlet side of the StormFilter weir.

Minor Service

This service is designed to ensure the ongoing operational effectiveness of the StormFilter system, whilst assessing the condition of the cartridge media.

1. Establish a safe working area around the access point(s)
2. Remove access cover(s)
3. Evaluate StormFilter cartridge media (if exhausted schedule major service within 6 months)
4. Measure and record the level of accumulated sediment in the chamber (if sediment depth is less than 100 mm skip to step 9)
5. Remove StormFilter cartridges from the chamber
6. Use vacuum unit to removed accumulated sediment and pollutants in the chamber
7. Use high pressure water to clean StormFilter chamber
8. Re-install StormFilter cartridges
9. Replace access cover(s)

Major Service (Filter Cartridge Replacement)

For the StormFilter system a major service is reactionary process based on the outcomes from the minor service, specifically the evaluation of the cartridge media.

Trigger Event	Maintenance Action
Cartridge media is exhausted ^[1]	Replace StormFilter cartridge media ^[2]

[1] Multiple assessment methods are available, contact Ocean Protect for assistance
 [2] Replacement filter media and components are available for purchase from Ocean Protect.

This service is designed to return the StormFilter device back to optimal operating performance

1. Establish a safe working area around the access point(s)
2. Remove access cover(s)
3. By first removing the head cap, remove each individual cartridge hood to allow access to the exhausted media.
4. Utilise a vacuum unit to remove exhausted media from each cartridge
5. Use vacuum unit to remove accumulated sediment and pollutants in the chamber
6. Use high pressure water to clean StormFilter chamber
7. Inspect each empty StormFilter cartridges for any damage, rectify damage as required
8. Re-fill each cartridge with media in line with project specifications
9. Re-install replenished StormFilter cartridges
10. Replace access cover(s)

Additional Types of Maintenance

Occasionally, events on site can make it necessary to perform additional maintenance to ensure the continuing performance of the device.

Hazardous Material Spill

If there is a spill event on site, the StormFilter unit should be inspected and cleaned. Specifically, all captured pollutants and liquids from within the unit should be removed and disposed in accordance with any additional requirements that may relate to the type of spill event. Additionally, it will be necessary to inspect the filter cartridges and assess them for contamination, depending on the type of spill event it may be necessary to replace the filtration media.

Blockages

In the unlikely event that flooding occurs upstream of the StormFilter system the following steps should be undertaken to assist in diagnosing the issue and determining the appropriate response.

1. Inspect the upstream diversion structure (if applicable) ensuring that it is free of debris and pollutants
2. Inspect the StormFilter unit checking the underdrain manifold as well as both the inlet and outlet pipes for obstructions (e.g. pollutant build-up, blockage), which if present, should be removed.

Major Storms and Flooding

In addition to the scheduled activities, it is important to inspect the condition of the StormFilter after a major storm event. The focus is to inspect for damage and higher than normal sediment accumulation that may result from localised erosion. Where necessary damaged components should be replaced and accumulated pollutants should be removed and disposed.

Disposal of Waste Materials

The accumulated pollutants found in the StormFilter must be handled and disposed of in a manner that is in accordance with all applicable waste disposal regulations. When scheduling maintenance, consideration must be made for the disposal of solid and liquid wastes. If the filter media has been contaminated with any unusual substance, there may be additional special handling and disposal methods required to comply with relevant government/authority/industry regulations.

Maintenance Services

With over a decade and a half of maintenance experience Ocean Protect has developed a systematic approach to inspecting, cleaning and maintaining a wide variety of stormwater treatment devices. Our fully trained and professional staff are familiar with the characteristics of each type of system, and the processes required to ensure its optimal performance.

Ocean Protect has several stormwater maintenance service options available to help ensure that your stormwater device functions properly throughout its design life. In the case of our StormFilter system we offer long term pay-as-you-go contracts, pre-paid once off servicing and replacement media for cartridges.

For more information please visit www.OceanProtect.com.au