

NOT FOR CONSTRUCTION



Proposed Light Industrial Development
 No.52 Cedar Mill Drive, Jillyby. N.S.W.
 Comprising Fiften (15) Units

GENERAL NOTES

- ALL CONSTRUCTION TO COMPLY WITH THE CURRENT PROVISIONS OF THE BUILDING CODE OF AUSTRALIA (BCA) & ANY APPLICABLE AUSTRALIAN STANDARD
- SITE INFORMATION SHOWN ON THIS DRAWING HAS BEEN SUPPLIED BY OTHERS. NO RESPONSIBILITY IS TAKEN FOR ITS AUTHENTICITY OR ACCURACY.
- THE BUILDER SHALL VERIFY LOCATION OF SERVICES, VEGETATION AND DIMENSIONS PRIOR TO COMMENCEMENT, ANY DISCREPANCIES SHOULD BE REPORTED TO THE DESIGNER
- FIGURED DIMENSIONS TO BE TAKEN IN PREFERENCE TO SCALE
- DIMENSIONS ARE IN MILLIMETRES U.N.O.
- CONTOURS & R.L.'S ARE IN METERS LEVELS SHOWN ARE TO THE AUSTRALIAN HEIGHT DATUM (A.H.D.)
- ALL DIMENSIONS SHALL BE CHECKED AND VERIFIED BY THE BUILDER PRIOR TO COMMENCEMENT OF WORKS.
- ALL REINFORCED CONCRETE SHALL BE IN ACCORDANCE WITH ENGINEER'S DETAIL DRAWINGS
- ALL ROOF WATER TO BE COLLECTED IN A SERIES OF GUTTERS & DOWNPIPES AND DRAINED TO THE EXISTING STORMWATER SYSTEM.
- ALL DOORS TO ACHIEVE THE REQUIRED MIN. 860mm OPENING REQUIRED BY AS1428.1-2021
- ALL STAIRWAYS TO COMPLY WITH CLAUSE 11 OF AS1428.1-2009.
- THE AREA UNDER ALL STAIRWAYS IS NOT TO BE ENCLOSED.
- TACTILE GROUND SURFACE INDICATORS (TGS) TO BE INSTALLED AT THE BASE AND TOP OF EACH STAIRCASE IN ACCORDANCE WITH AS1428.4.1-2009 & AS1428.1-2009.

SITE CALCULATIONS

SITE AREA	5,000 sqm
GROUND FLOOR GFA	2,335 sqm
MEZZANINE FLOORS	304 sqm
SUB TOTAL	2,639 sqm
<u>LOADING BAYS CONCESSION</u>	-15 x 22.4 = 337 sqm
TOTAL GFA	2,302 sqm
CAR SPACES REQUIRED	24 (1 per 100 sqm of GFA)
CAR SPACES PROVIDED	30
SITE COVER	2426 sqm (48.5%)

DRAWINGS

- A101 SITE PLAN
- A102 FOUNDATION PLAN
- A103 GROUND FLOOR PLAN
- A104 FIRST FLOOR PLAN
- A105 ROOF PLAN
- A106 ELEVATIONS U1-5
- A107 ELEVATIONS U6-10
- A108 ELEVATIONS U11-15
- A109 SECTIONS
- A110 SECTIONS
- A111 STAIR DETAIL
- A112 STAIR DETAIL
- A120 WINDOW SCHEDULE
- A130 BATHROOM FLOOR PLAN
- A131 BATHROOM ELEVATIONS
- A132 BATHROOM ELEVATIONS
- A140 AWNING DETAIL
- A141 BUSINESS IDENTIFICATION SIGN

These drawings & designs are the property of MJ Cassidy & Associates Pty. Limited and shall not be reproduced without explicit written consent of the owner



VALLETTA HOMES

Ref.No. 2502_0476
 Date FEB. 2025

Location LOT 19 IN DP
 No.52 CEDAR MILL DR, JILLYBY NSW

Drawing

COVER SHEET

1	xx/xx/xx	ISSUED FOR APPROVAL
Rev.	Date	Description
Revision		A100
Scale	NTS	

NOT FOR CONSTRUCTION

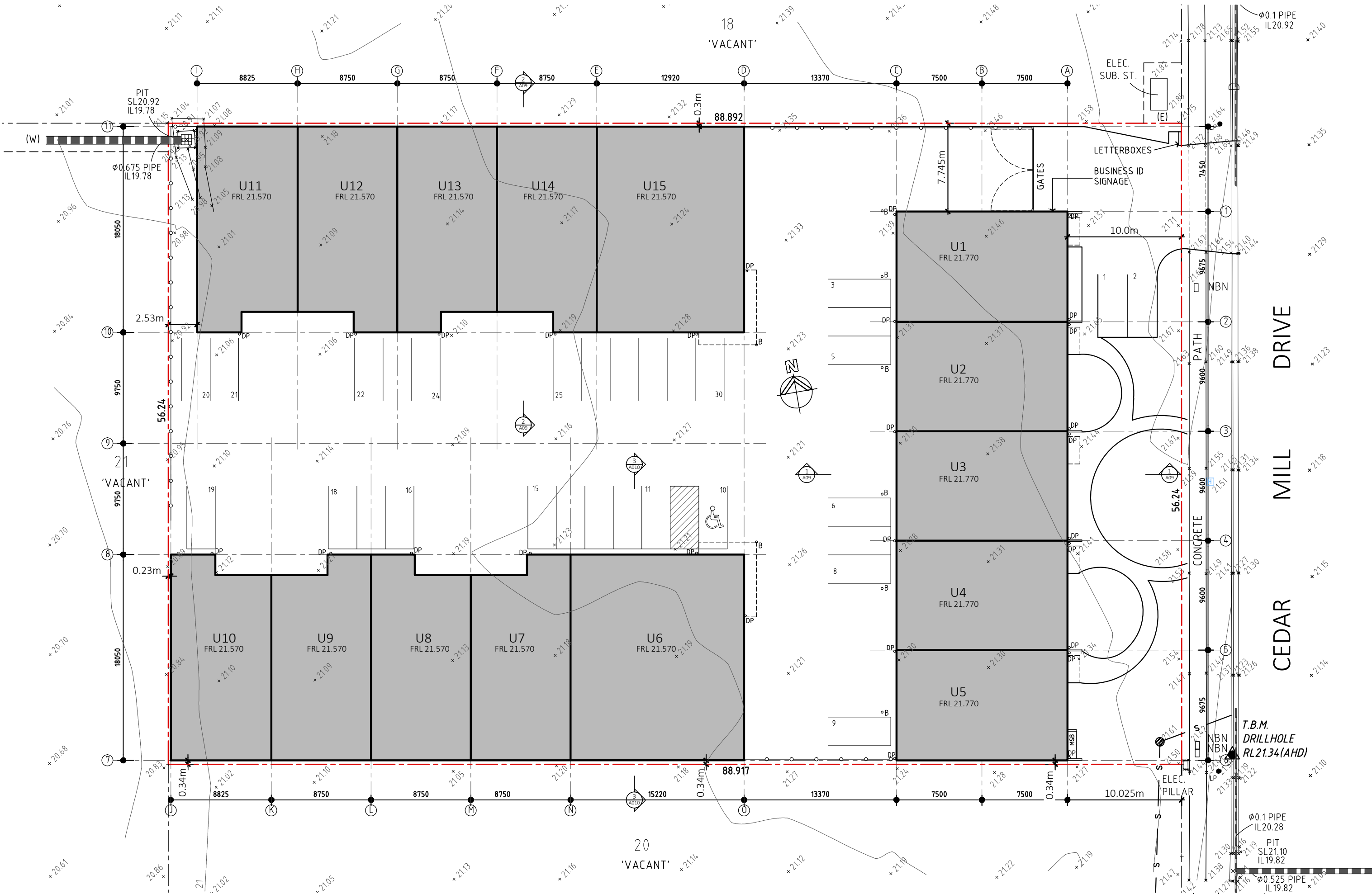

- (E) PROPOSED EASEMENT FOR ELECTRICITY AND OTHER PURPOSES 3.3 WIDE
- (W) PROPOSED EASEMENT FOR DRAINAGE OF WATER VARIABLE WIDTHS

These drawings & designs are the property of MJ Cassidy & Associates Pty. Limited and shall not be reproduced without explicit written consent of the owner

MJC
M.J.CASSIDY & ASSOC. PTY.LTD. 0437291376

VALLETTA HOMES

Ref.No. 2502_0476
Date FEB. 2025

Location LOT 19 IN DP
No.52 CEDAR MILL DR, JILLIBY NSW

Drawing SITE PLAN

Rev.	Date	Description
1	x/x/x	ISSUED FOR APPROVAL
Revision		A101
Scale		1:300 @ A3

NOT FOR CONSTRUCTION

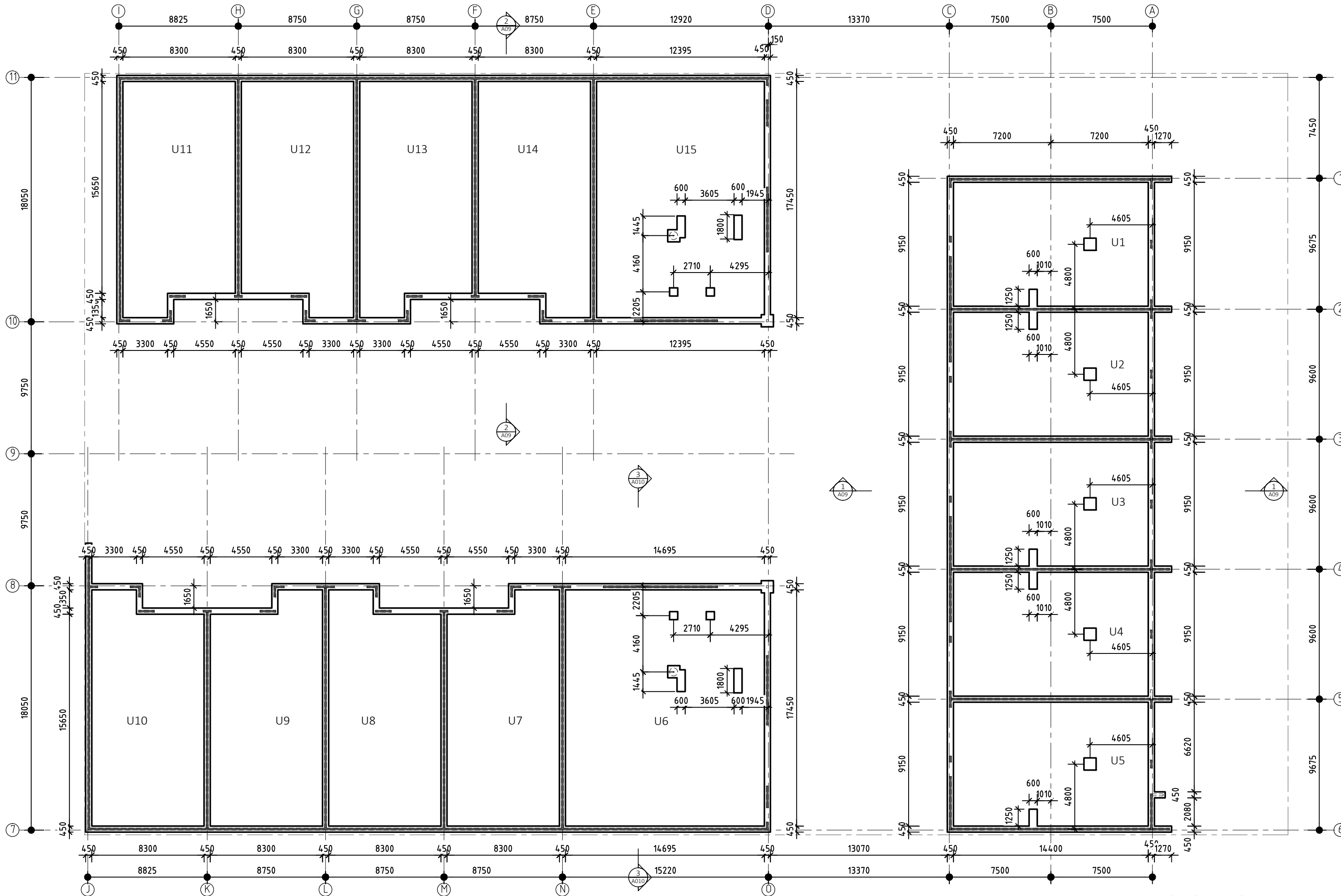

These drawings & designs are the property of MJ Cassidy & Associates Pty. Limited and shall not be reproduced without explicit written consent of the owner

MJC
M.J.CASSIDY & ASSOC. PTY.LTD. 0437291376

VALLETTA HOMES

Ref.No. 2502_0476
Date FEB. 2025

Location LOT 19 IN DP
No.52 CEDAR MILL DR, JILLIBY NSW

Drawing
FOUNDATION PLAN

Rev.	Date	Description

Revision
Scale 1:250 @ A3

A102

NOT FOR CONSTRUCTION

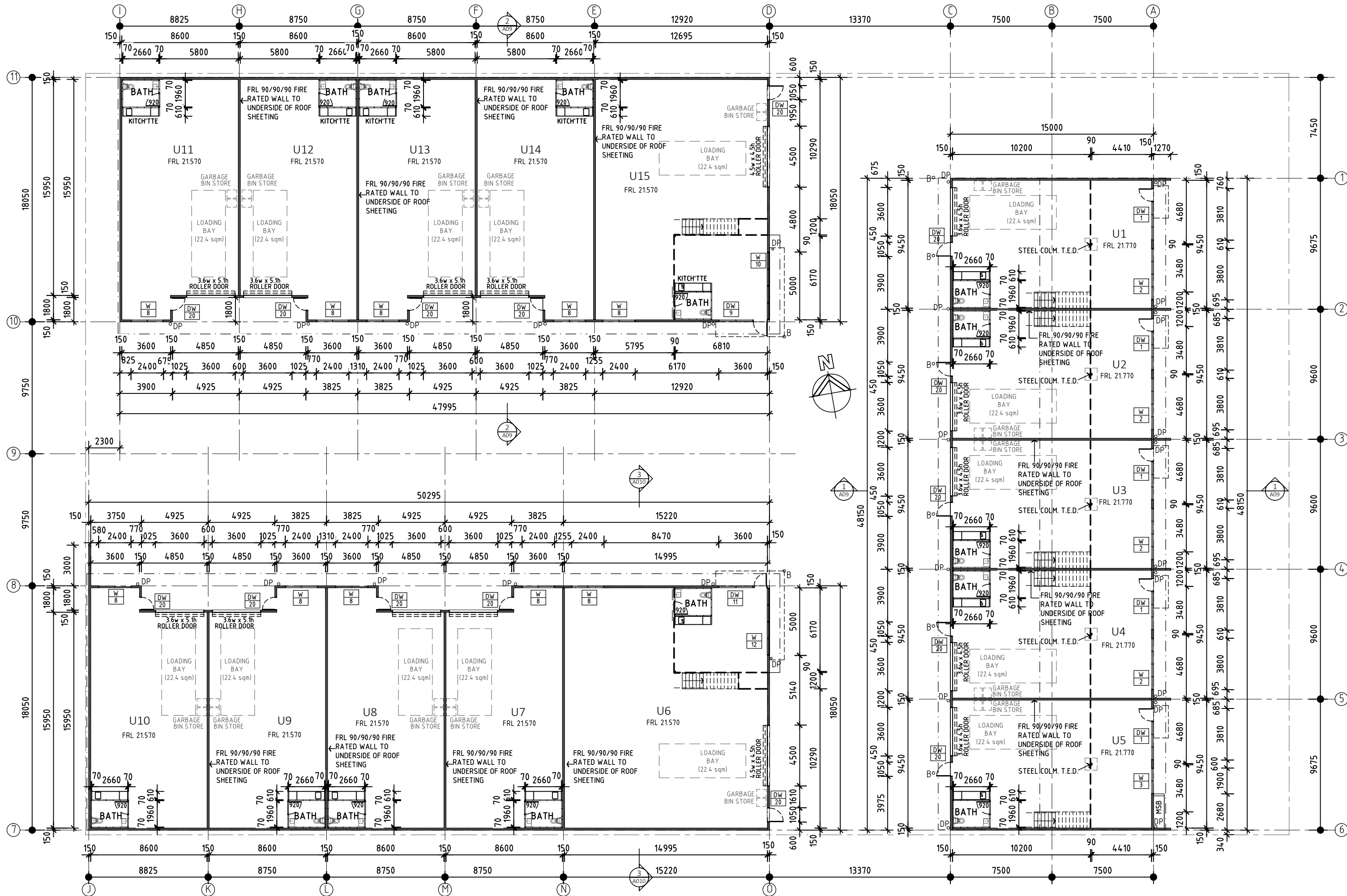

These drawings & designs are the property of MJ Cassidy & Associates Pty. Limited and shall not be reproduced without explicit written consent of the owner

MJC
M.J.CASSIDY & ASSOC. PTY.LTD. 0437291376

VALLETTA HOMES

Ref.No. 2502_0476
Date FEB. 2025

Location LOT 19 IN DP
No.52 CEDAR MILL DR, JILLIBY NSW

Drawing
GROUND FLOOR PLAN

Rev.	Date	Description

Revision
Scale 1:250 @ A3

A103

NOT FOR CONSTRUCTION

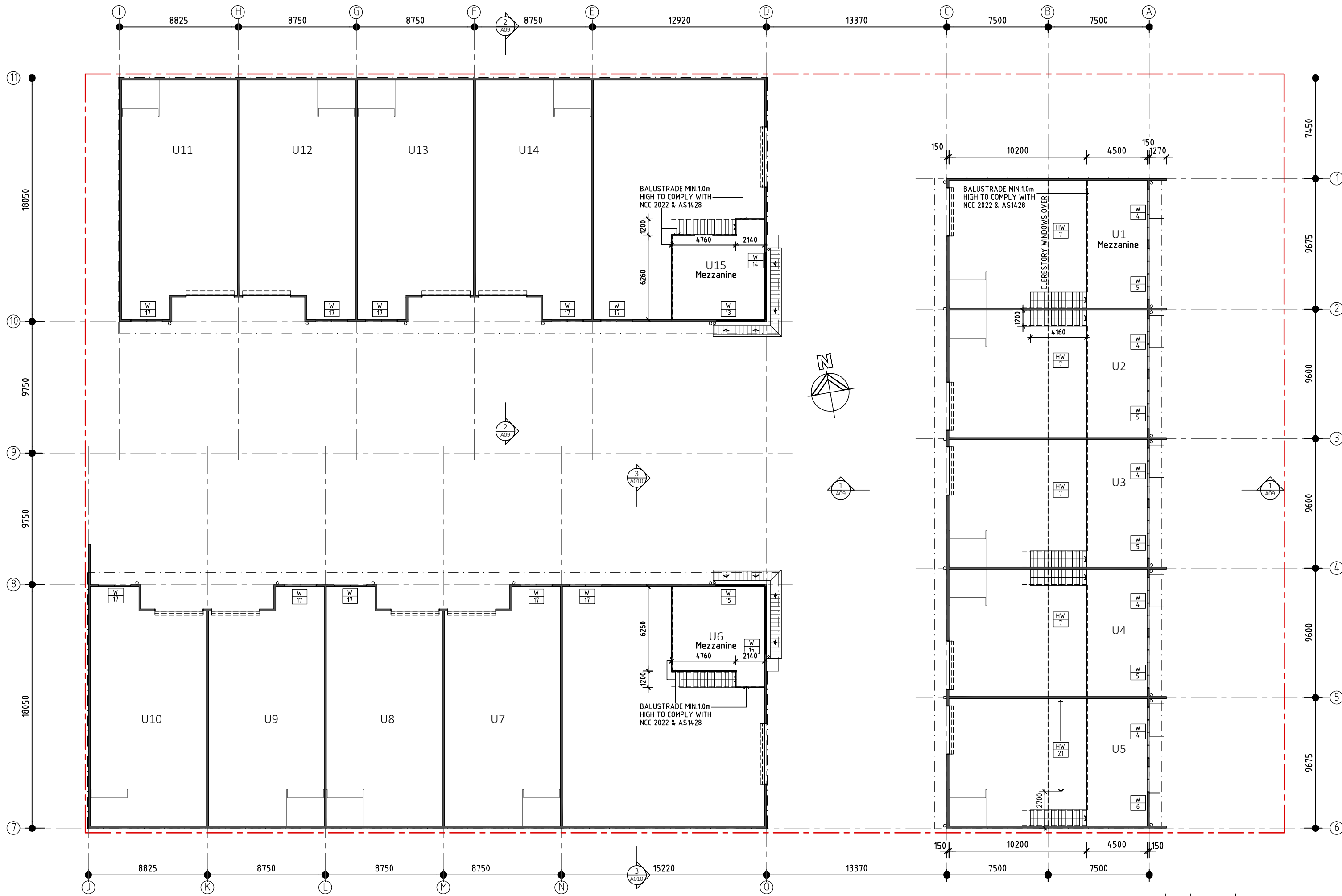

These drawings & designs are the property of MJ Cassidy & Associates Pty. Limited and shall not be reproduced without explicit written consent of the owner

MJC
M.J.CASSIDY & ASSOC. PTY.LTD. 0437291376

VALLETTA HOMES

Ref.No. 2502_0476
Date FEB. 2025

Location LOT 19 IN DP
No.52 CEDAR MILL DR, JILLIBY NSW

Drawing
FIRST FLOOR PLAN

Rev.	Date	Description

Revision
Scale 1:250 @ A3

A104

NOT FOR CONSTRUCTION

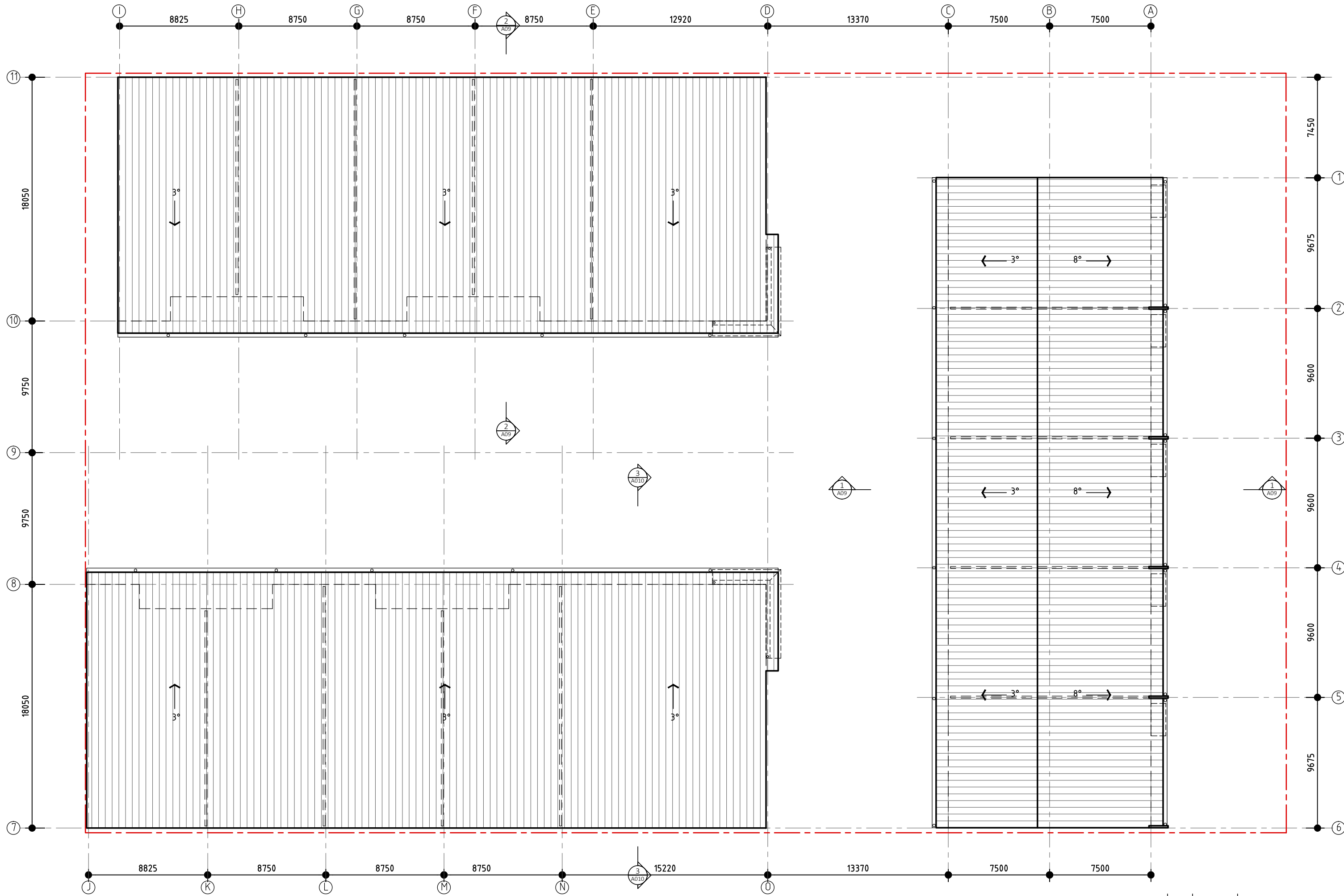

These drawings & designs are the property of MJ Cassidy & Associates Pty. Limited and shall not be reproduced without explicit written consent of the owner

MJC
M.J.CASSIDY & ASSOC. PTY.LTD. 0437291376

VALLETTA HOMES

Ref.No. 2502_0476
Date FEB. 2025

Location LOT 19 IN DP
No.52 CEDAR MILL DR, JILLIBY NSW

Drawing
ROOF PLAN

Rev.	Date	Description

A105

Scale 1:250 @ A3

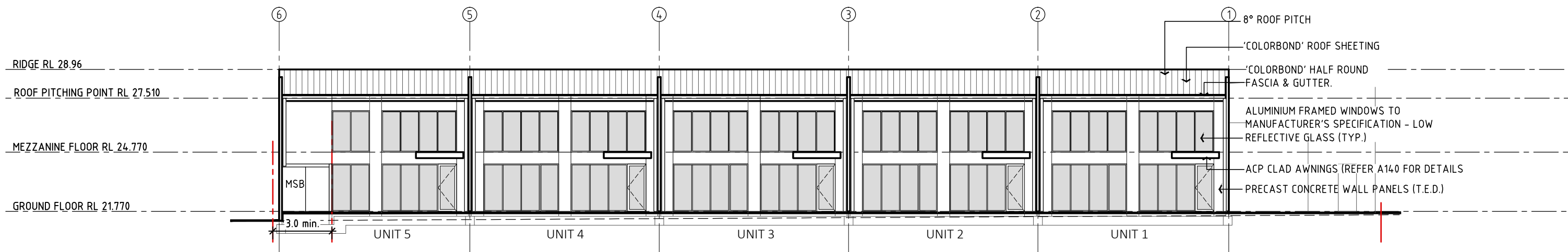

○ CEDAR MILL DR ELEVATION
SCALE 1:200 @ A3

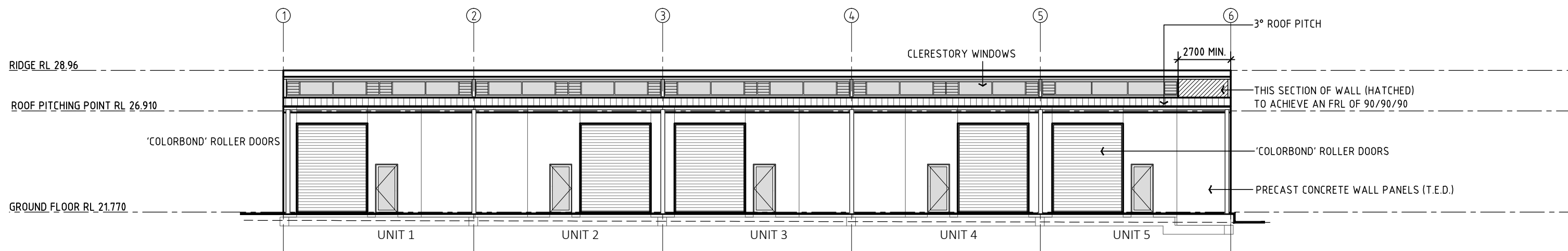

○ U1-5 WEST ELEVATION
SCALE 1:200 @ A3

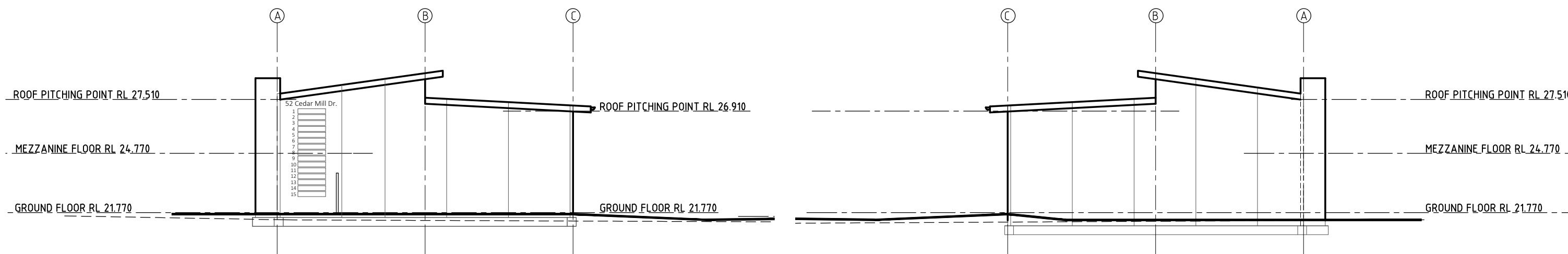

○ U1-5 NORTH ELEVATION
SCALE 1:200 @ A3

○ U1-5 SOUTH ELEVATION
SCALE 1:200 @ A3

NOT FOR CONSTRUCTION

These drawings & designs are the property of MJ Cassidy & Associates Pty. Limited and shall not be reproduced without explicit written consent of the owner

MJC
M.J.CASSIDY & ASSOC. PTY.LTD. 0437291376

VALLETTA HOMES

Ref.No. 2502_0476
Date FEB. 2025

Location LOT 19 IN DP
No.52 CEDAR MILL DR, JILLIBY NSW

Drawing
ELEVATIONS U1-5

Rev.	Date	Description

Revision
Scale 1:200 @ A3

A106

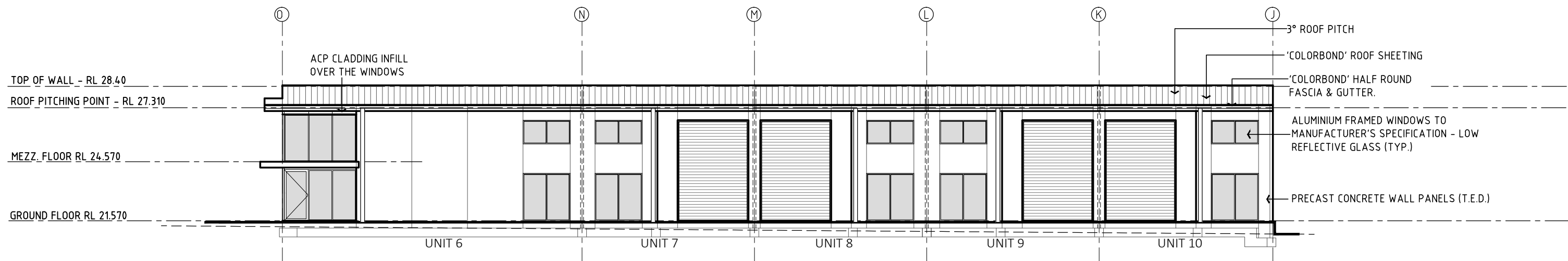

U6-10 NORTH ELEVATION
SCALE 1:200 @ A3

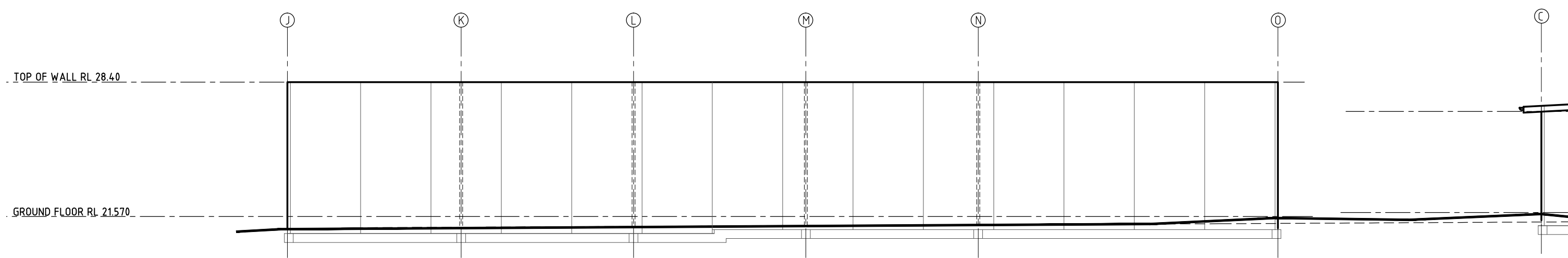

U6-10 SOUTH ELEVATION
SCALE 1:200 @ A3

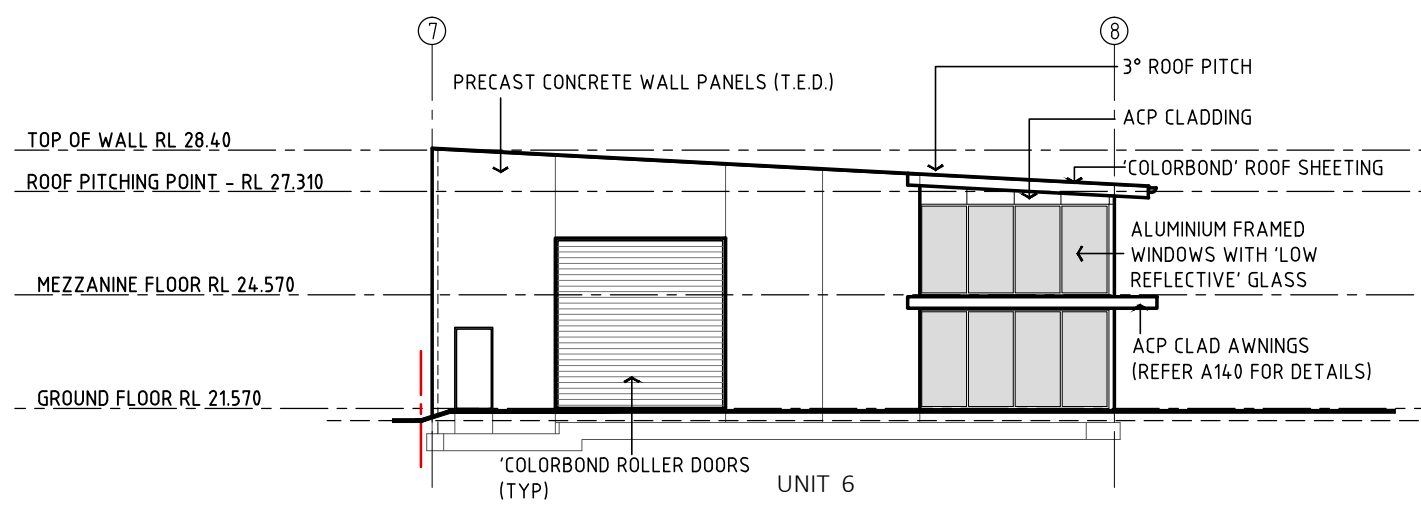

U6-10 EAST ELEVATION
SCALE 1:200 @ A3

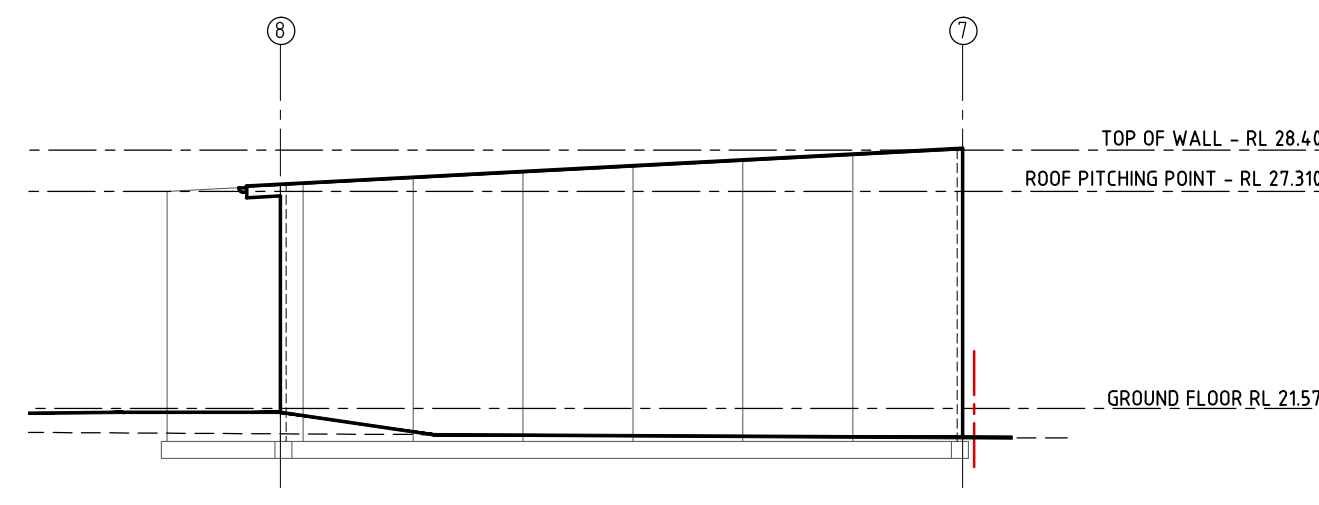

U6-10 WEST ELEVATION
SCALE 1:200 @ A3

NOT FOR CONSTRUCTION

These drawings & designs are the property of MJ Cassidy & Associates Pty. Limited and shall not be reproduced without explicit written consent of the owner

MJC
M.J.CASSIDY & ASSOC. PTY.LTD. 0437291376

VALLETTA HOMES

Ref.No. 2502_0476
Date FEB. 2025

Location LOT 19 IN DP
No.52 CEDAR MILL DR, JILLIBY NSW

Drawing
ELEVATIONS U6-10

Rev.	Date	Description

Revision
Scale 1:200 @ A3

A107

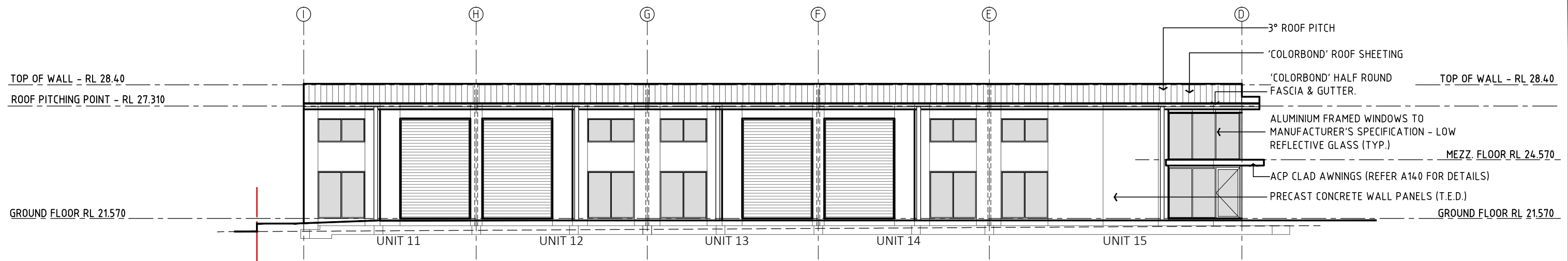

U6-10 SOUTH ELEVATION
SCALE 1:200 @ A3

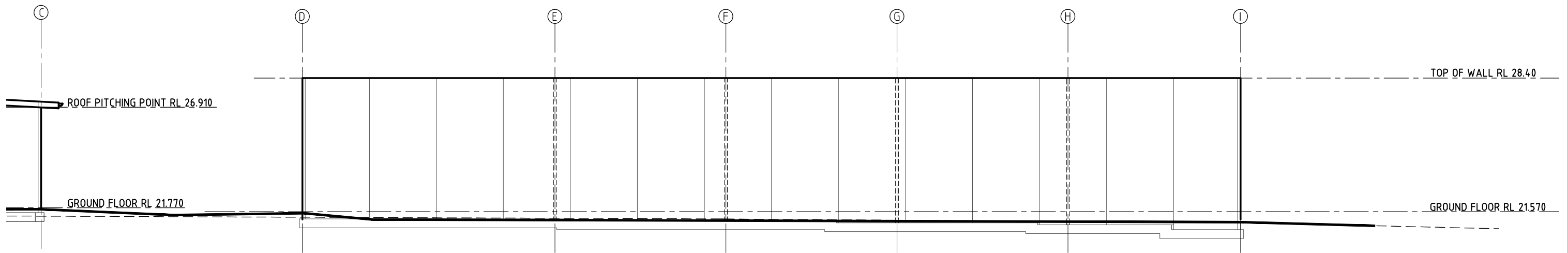

U6-10 NORTH ELEVATION
SCALE 1:200 @ A3

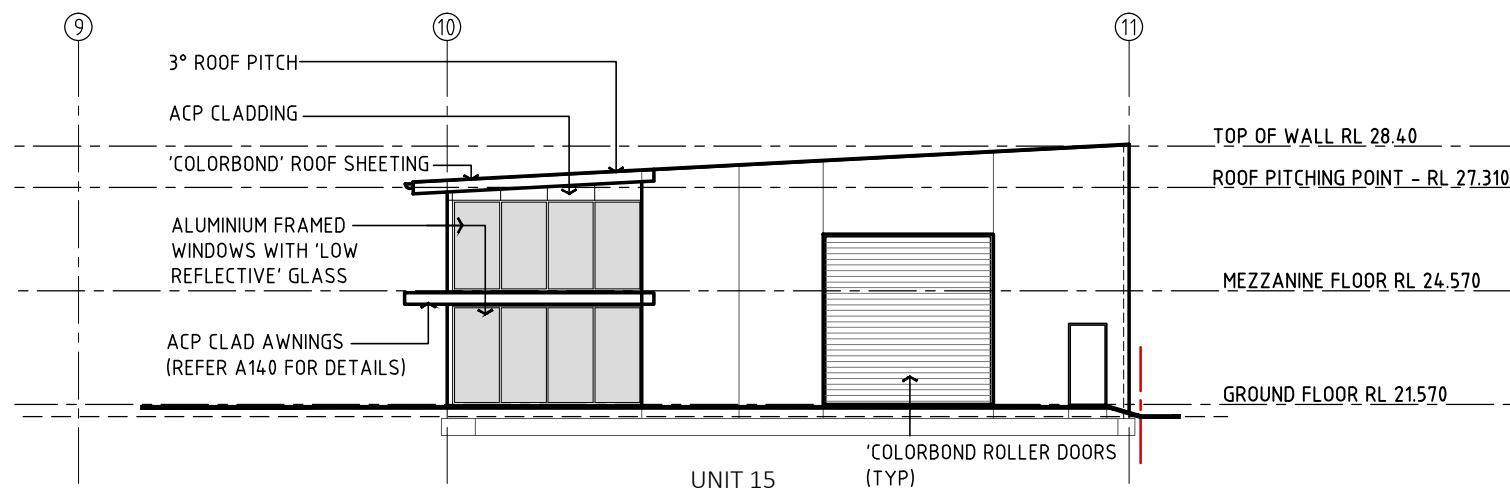

U6-10 EAST ELEVATION
SCALE 1:200 @ A3

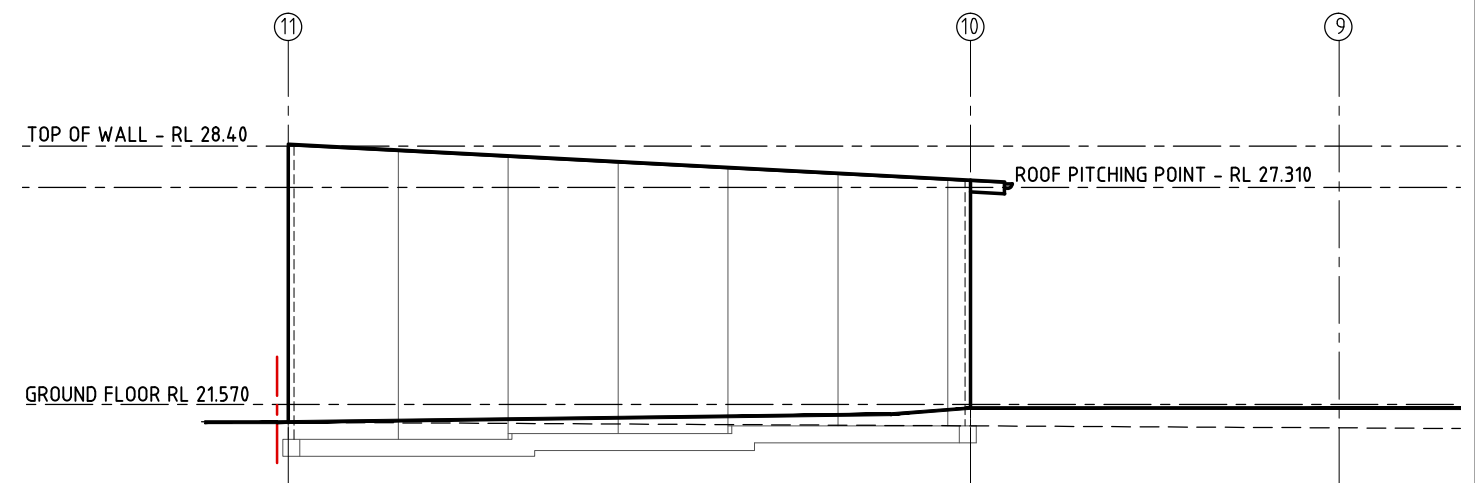

U6-10 WEST ELEVATION
SCALE 1:200 @ A3

NOT FOR CONSTRUCTION

These drawings & designs are the property of MJ Cassidy & Associates Pty. Limited and shall not be reproduced without explicit written consent of the owner

MJC
M.J.CASSIDY & ASSOC. PTY.LTD. 0437291376

VALLETTA HOMES

Ref.No. 2502_0476
Date FEB. 2025

Location LOT 19 IN DP
No.52 CEDAR MILL DR, JILLIBY NSW

Drawing
ELEVATIONS U11-15

1	x/x/x	ISSUED FOR APPROVAL
Rev.	Date	Description
Revision		A108
Scale		1:200 @ A3

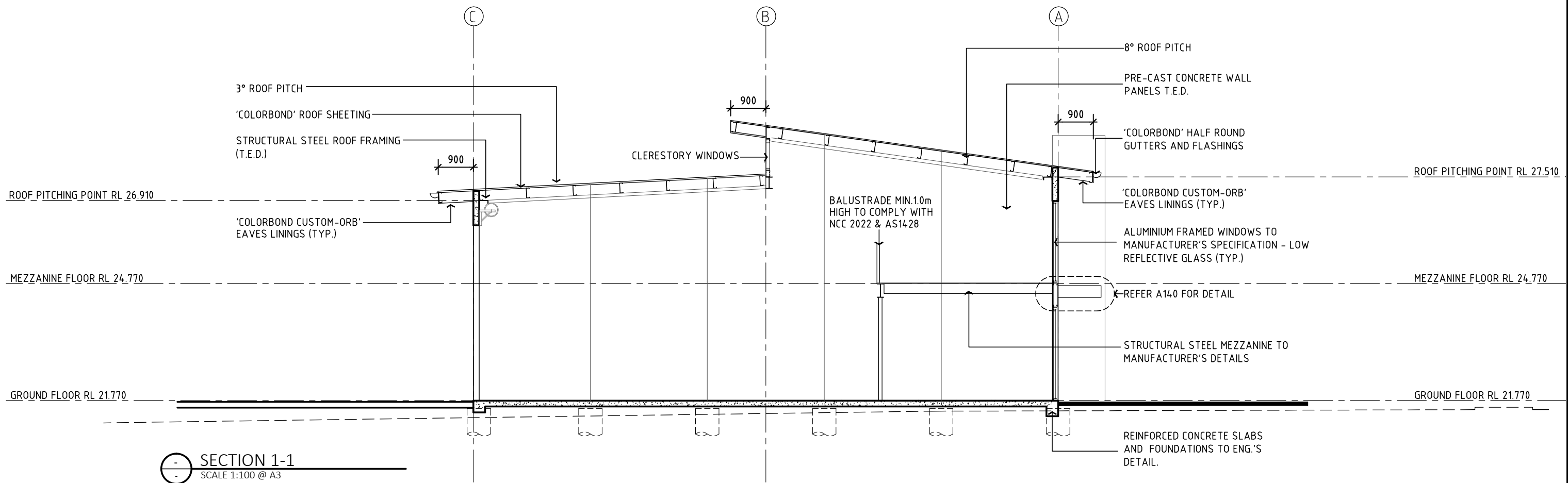

SECTION 1-1
SCALE 1:100 @ A3

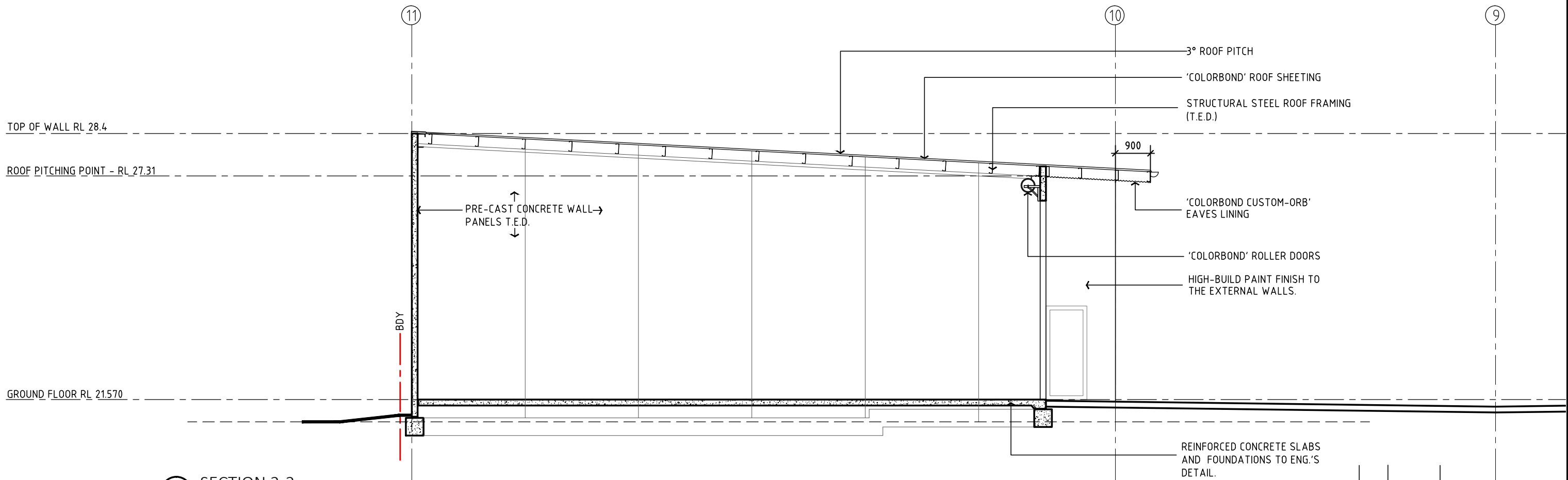

SECTION 2-2
SCALE 1:100 @ A3

NOT FOR CONSTRUCTION

These drawings & designs are the property of MJ Cassidy & Associates Pty. Limited and shall not be reproduced without explicit written consent of the owner

MJC
M.J.CASSIDY & ASSOC. PTY.LTD. 0437291376

VALLETTA HOMES

Ref.No. 2502_0476
Date FEB. 2025

Location LOT 19 IN DP
No.52 CEDAR MILL DR, JILLIBY NSW

Drawing

SECTIONS

1	x/x/x	ISSUED FOR APPROVAL
Rev.	Date	Description

Revision
Scale 1:100 @ A3

A109

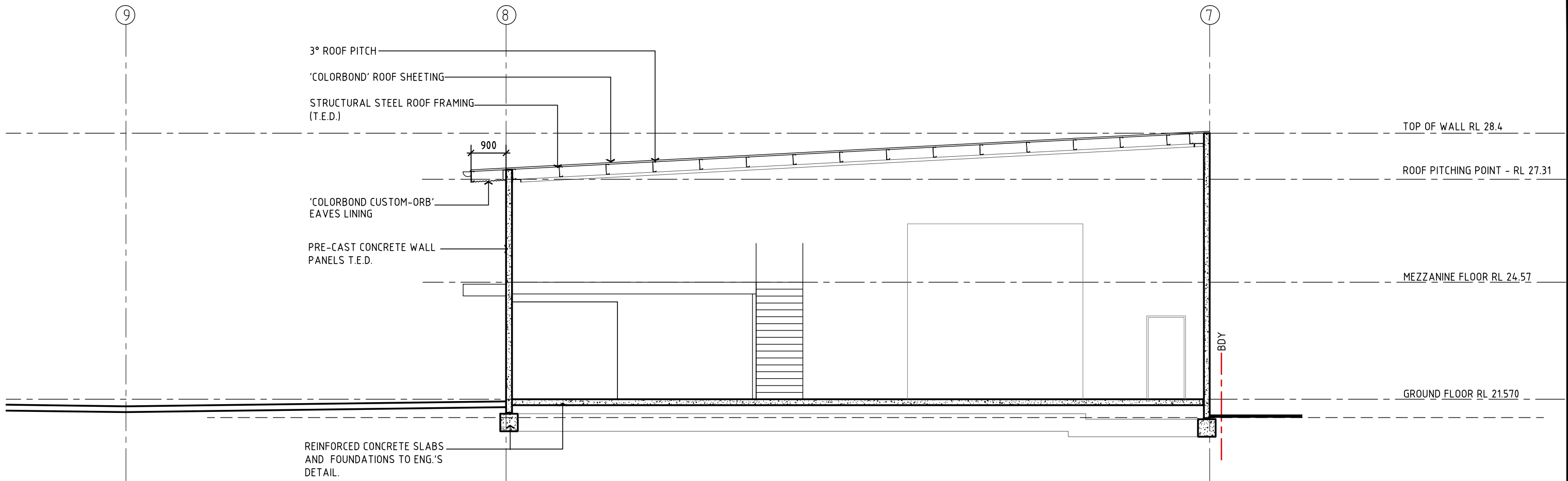

SECTION 3-3
SCALE 1:100 @ A3

NOT FOR CONSTRUCTION

These drawings & designs are the property of MJ Cassidy & Associates Pty. Limited and shall not be reproduced without explicit written consent of the owner

MJC
M.J.CASSIDY & ASSOC. PTY.LTD. 0437291376

VALLETTA HOMES

Ref.No. 2502_0476
Date FEB. 2025

Location LOT 19 IN DP
No.52 CEDAR MILL DR, JILLIBY NSW

Drawing

SECTIONS

1	x/x/x	ISSUED FOR APPROVAL
Rev.	Date	Description
Revision		A110
Scale		1:100 @ A3

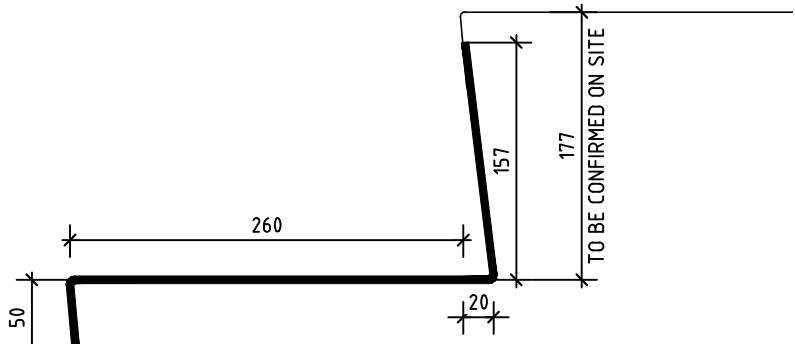

2 TYPICAL TREAD DETAIL
SCALE 1:5 @ A3

STRINGERS
TO ENGINEER'S DETAIL
(HOT DIP GALVANISED FINISH)

FOLDED 'CHECKER PLATE' TREADS
(THICKNESS TO ENG.S DETAIL)
ALL TREADS TO COMPLY WITH AS1428.1-2009
INCLUDING STRIP OF CONTRASTING COLOUR 50-70mm WIDE

HOT DIP GALVANISED HANDRAILS AND BAULSTRADE
TO COMPLY WITH AS1428.01-2009

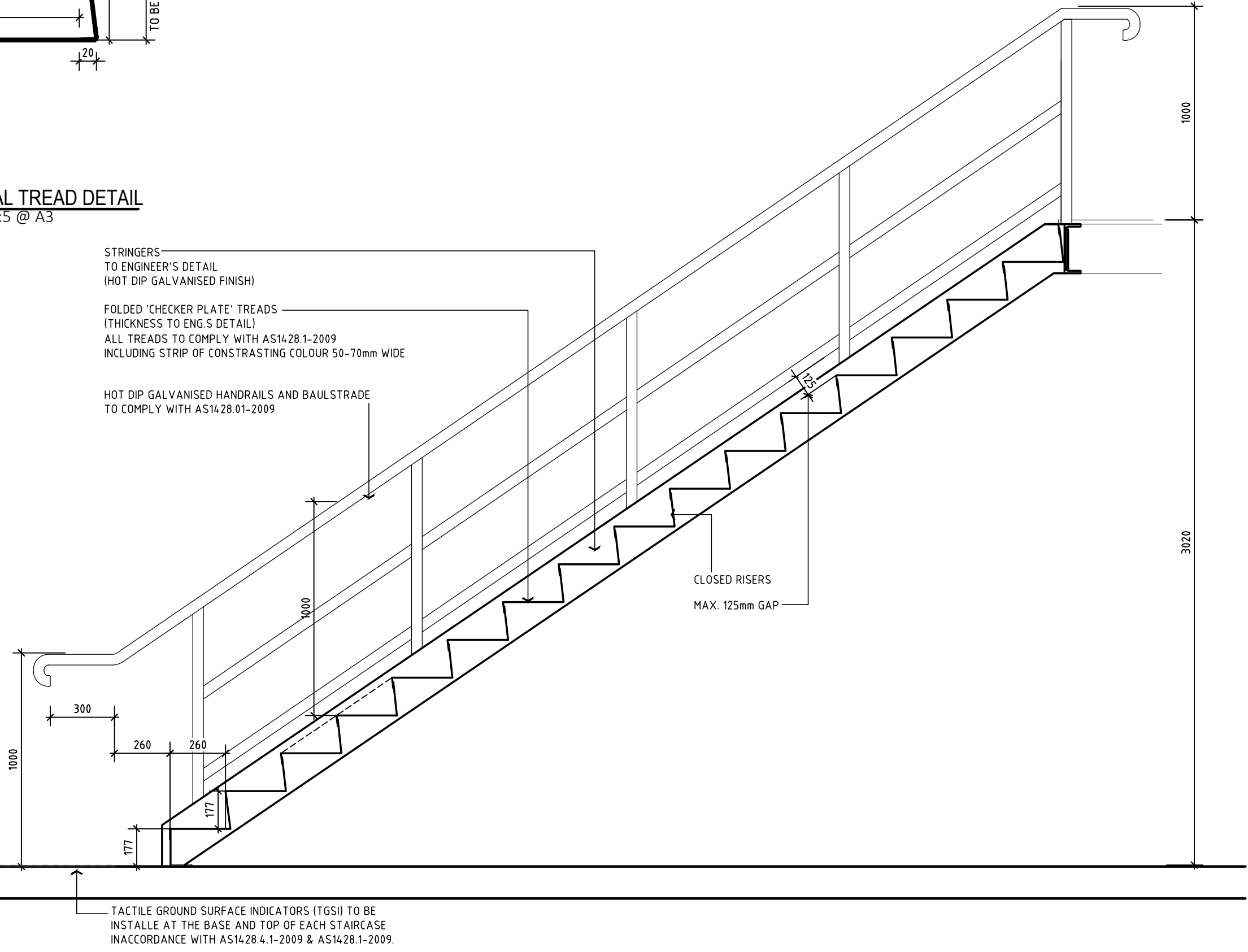

TACTILE GROUND SURFACE INDICATORS (TGSII) TO BE
INSTALLED AT THE BASE AND TOP OF EACH STAIRCASE
IN ACCORDANCE WITH AS1428.4.1-2009 & AS1428.1-2009.

1 SECTION
SCALE 1:20 @ A3

1	xx/x/xx	ISSUED FOR APPROVAL
Rev.	Date	Description

NOT FOR CONSTRUCTION

These drawings & designs are the property of MJ Cassidy & Associates Pty. Limited and shall not be reproduced without explicit written consent of the owner

MJC
M.J.CASSIDY & ASSOC. PTY.LTD. 0437291376

VALLETTA HOMES

Ref.No. 2502_0476
Date FEB. 2025

Location LOT 19 IN DP
No.52 CEDAR MILL DR, JILLIBY NSW

Drawing
STAIR DETAIL - SECTION

Revision
Scale AS SHOWN

A112

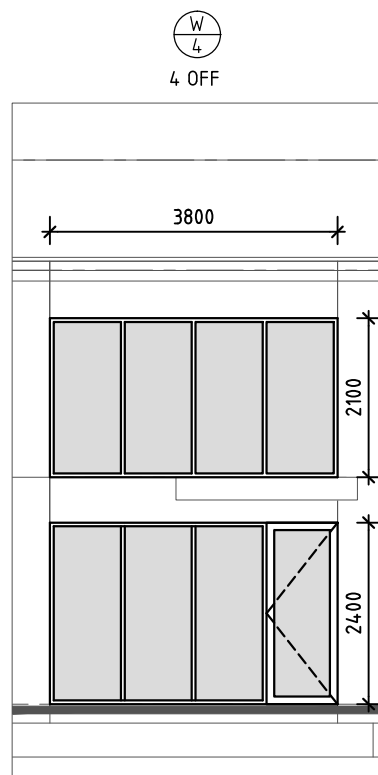

W4
4 OFF

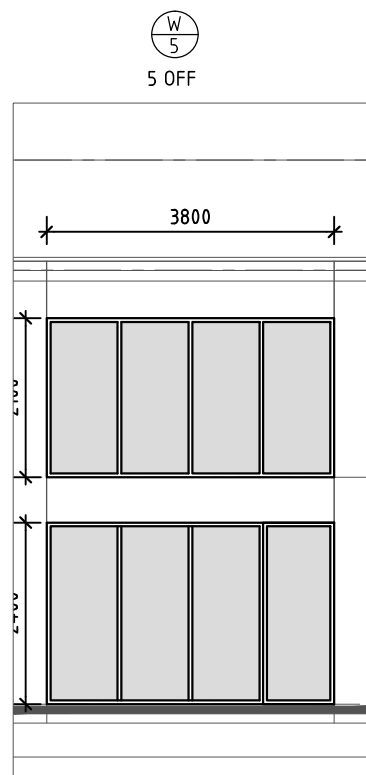

W5
5 OFF

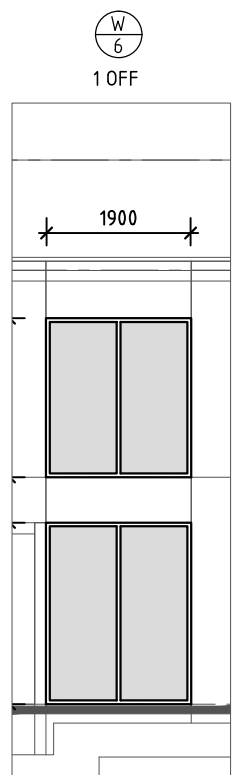

W6
1 OFF

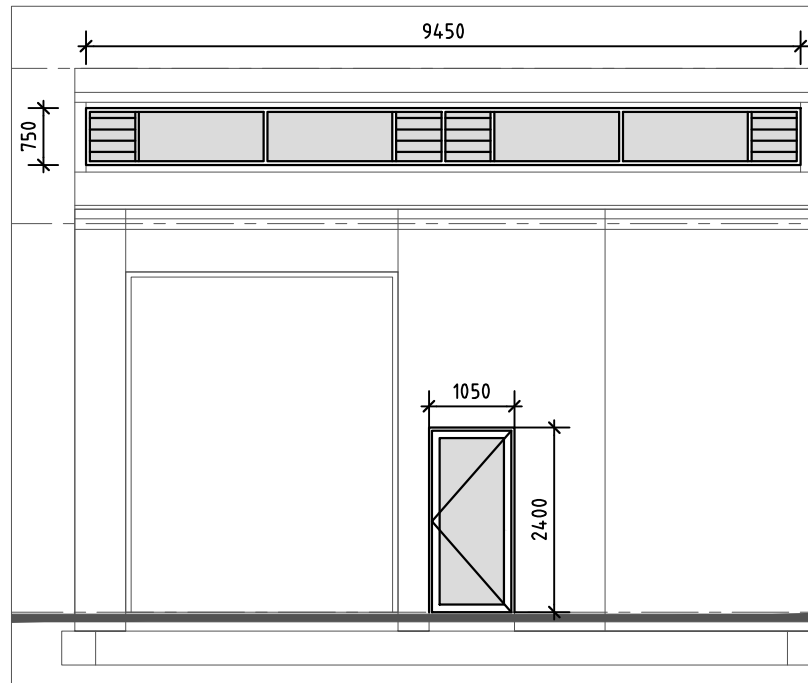

HW7
4 OFF

DW20
5 OFF

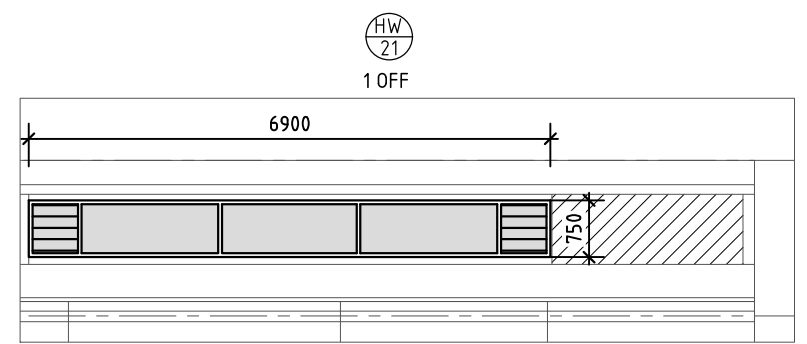

HW21
1 OFF

UNIT 5

UNITS 1-5

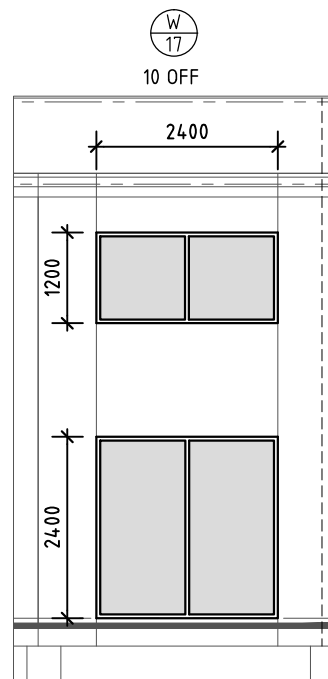

W17
10 OFF

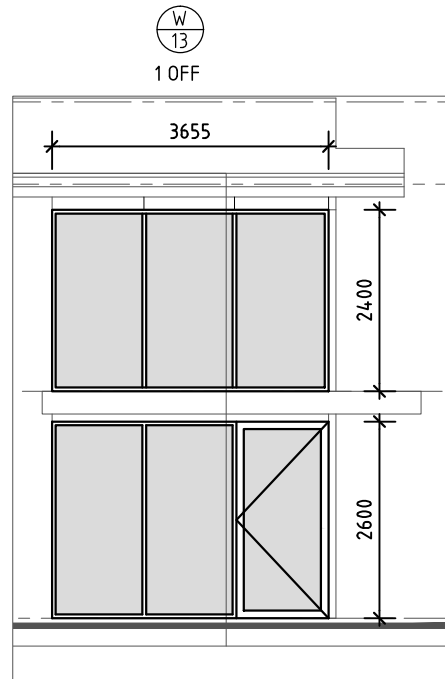

W13
1 OFF

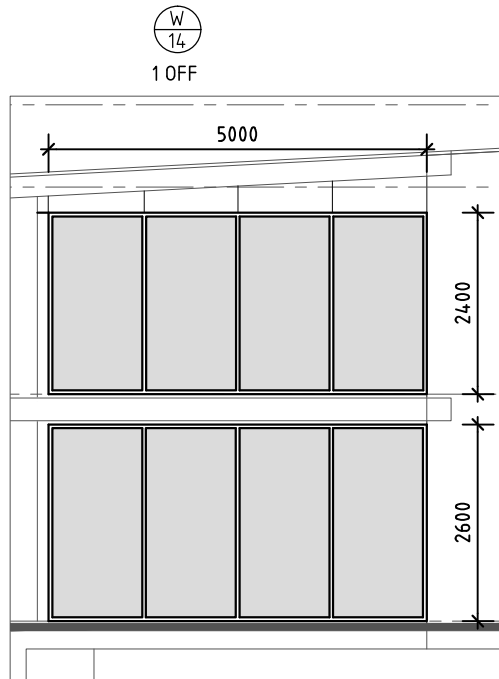

W14
1 OFF

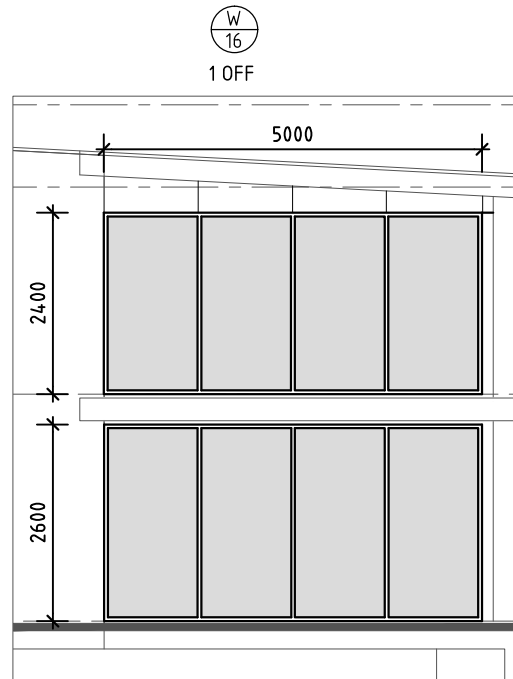

W16
1 OFF

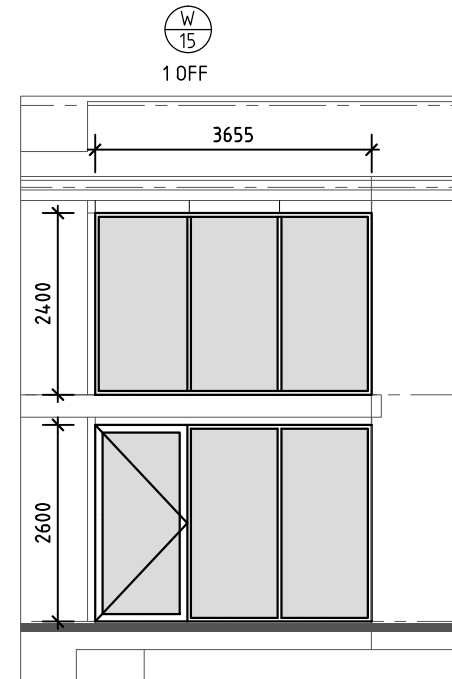

W15
1 OFF

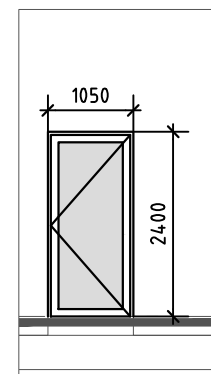

DW20
10 OFF

W8
10 OFF

W9
1 OFF

W10
1 OFF

W12
1 OFF

W11
1 OFF

UNITS 6-15

NOTES

- DOORS TO HAVE MIN. 860mm CLEAR OPENING IN ACCORDANCE WITH AS1428.01-2021
- DIMENSIONS SHOWN ARE OPENING SIZES ONLY.
- ACTUAL WINDOW FRAME SIZING TO THE BUILDER AND MANUFACTURER'S SPECIFICATION.

These drawings & designs are the property of MJ Cassidy & Associates Pty. Limited and shall not be reproduced without explicit written consent of the owner

MJC
M.J.CASSIDY & ASSOC. PTY.LTD. 0437291376

VALLETTA HOMES

Ref.No. 2502_0476
Date FEB. 2025

Location LOT 19 IN DP
No.52 CEDAR MILL DR, JILLIBY NSW

Drawing
WINDOW SCHEDULE

1	xx/xx/xx	ISSUED FOR APPROVAL
Rev.	Date	Description
Revision		A120
Scale 1:250 @ A3		

NOT FOR CONSTRUCTION

NOT FOR CONSTRUCTION

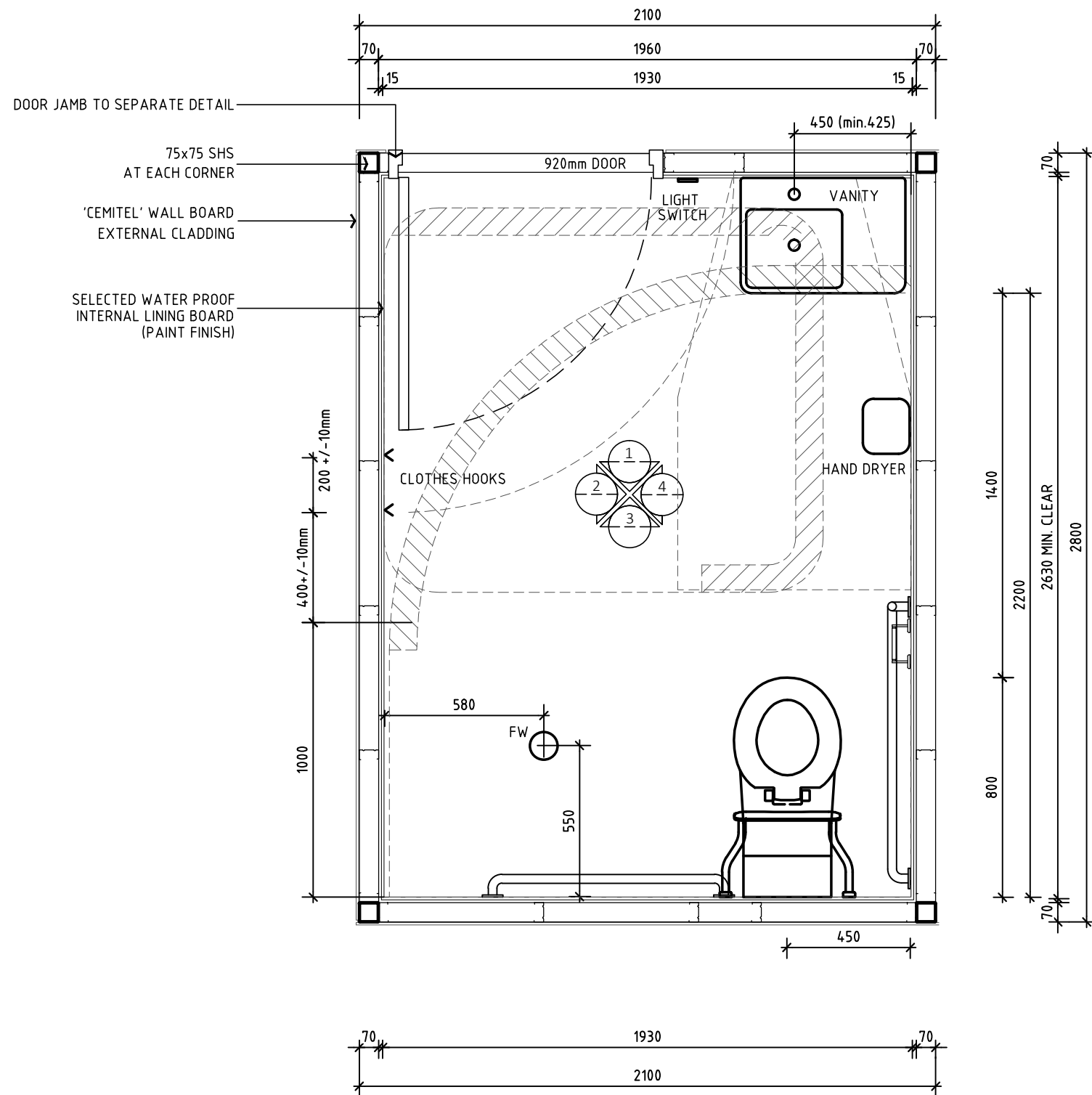

1 FLOOR PLAN
SCALE 1:20 @ A3

NOTES

General Overview Refer to AS 1428.1-2009

Doorway, Doors & Circulation Space at Doorways Refer to AS 1428.1-2009-Section 13

Luminance Contrast Refer to AS 1428.1-2009-Section 13.1

Clear Opening Doorways Refer to AS 1428.1-2009- Section 13.2 & Figure (30)

Circulation Space at Doorways on Continuous Accessible path of Travel Refer to AS 1428.1-2009-Section 13.3 AS 1428.1-2009-Figure (31) & (32)

Switches & Power Points Refer to AS 1428.1-2009-Section 14 AS 1428.1-2009-Figure 37

Sanitary Facilities Refer to AS 1428.1-2009-Section 15 Refer to figures 38-51

Signs to Toilets

1. Signage to comply with AS1428.1-2009 Section 8
2. In accordance with BCA clause D3.6: Braille and tactile signage complying with specification D3.6 and incorporating the international symbol of access is to be provided to all sanitary facilities within the building in accordance with as 1428.1-2009
3. Braille and tactile components of a sign must be located not less than 1200 mm and not higher than 1600 mm above the floor or ground surface; and
4. Signs must be located on the wall on the latch side of the door with the leading edge of the sign located between 50 mm and 300 mm from the architrave; and
5. Where 4 is not possible, the sign may be placed on the door itself

These drawings & designs are the property of MJ Cassidy & Associates Pty. Limited and shall not be reproduced without explicit written consent of the owner

MJC
M.J.CASSIDY & ASSOC. PTY.LTD. 0437291376

VALLETTA HOMES

Ref.No. 2502_0476
Date FEB. 2025

Location LOT 19 IN DP
No.52 CEDAR MILL DR, JILLIBY NSW

Drawing
BATHROOM FLOOR PLAN

1	xx/x/xx	ISSUED FOR APPROVAL
Rev.	Date	Description
Revision		A130
Scale 1:20 @ A3		

NOT FOR CONSTRUCTION

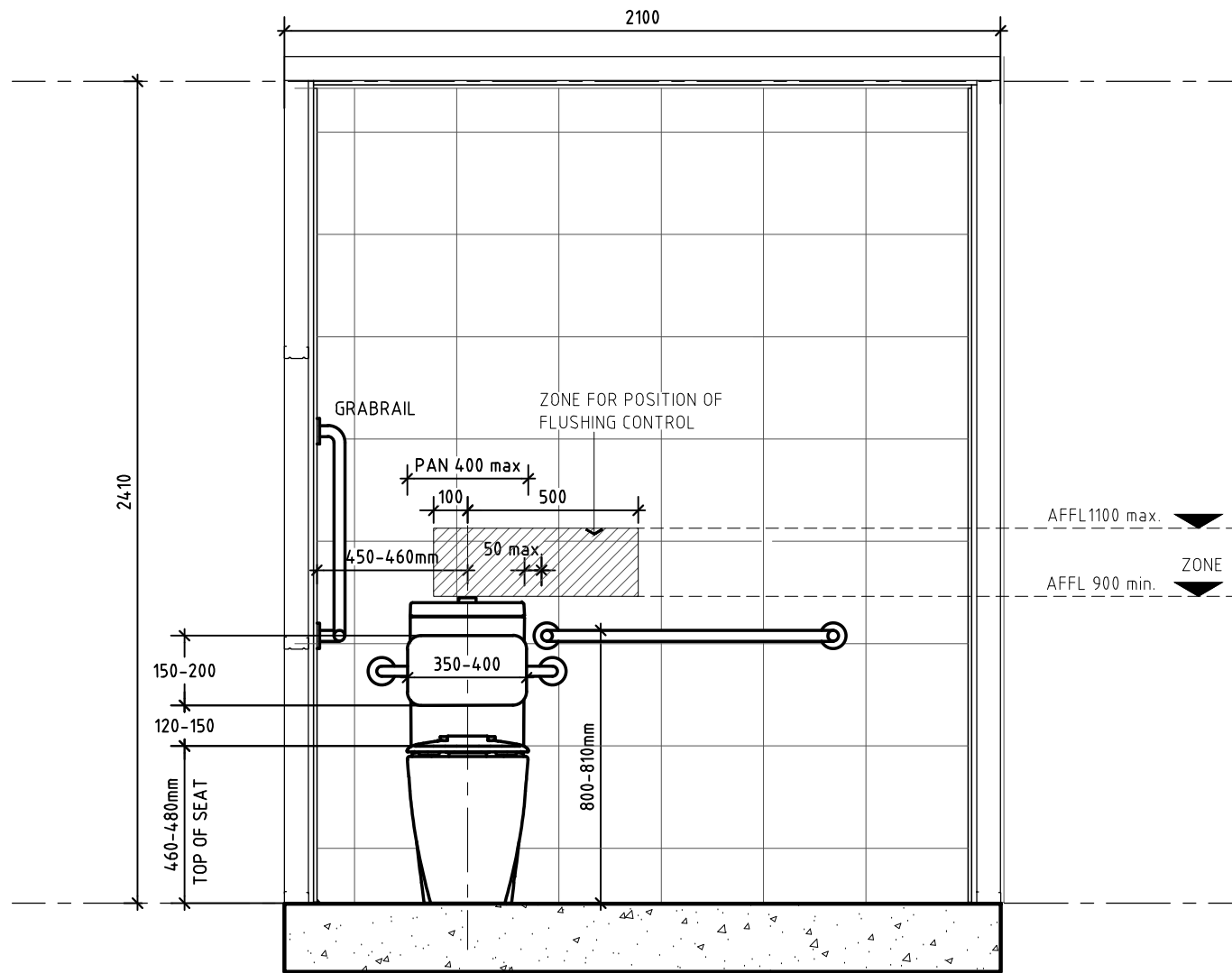

1 ELEVATION 1
- SCALE 1:20 @ A3

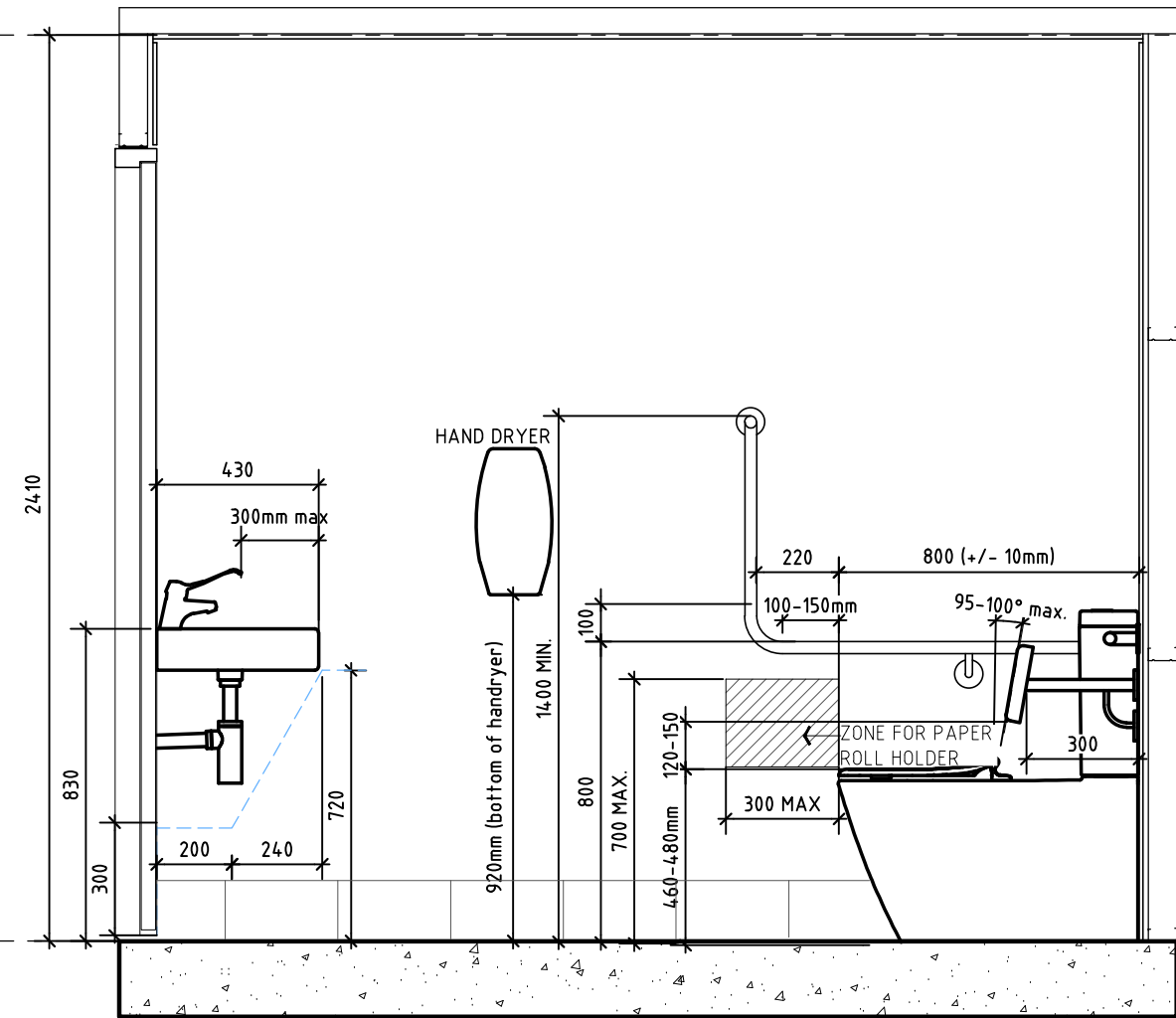

2 ELEVATION 2
- SCALE 1:20 @ A3

These drawings & designs are the property of MJ Cassidy & Associates Pty. Limited and shall not be reproduced without explicit written consent of the owner

MJC
M.J.CASSIDY & ASSOC. PTY.LTD. 0437291376

VALLETTA HOMES

Ref.No. 2502_0476
Date FEB. 2025

Location LOT 19 IN DP
No.52 CEDAR MILL DR, JILLIBY NSW

Drawing
BATHROOM ELEVATIONS

1	xx/x/xx	ISSUED FOR APPROVAL
Rev.	Date	Description
Revision		A131
Scale		1:20 @ A3

NOT FOR CONSTRUCTION

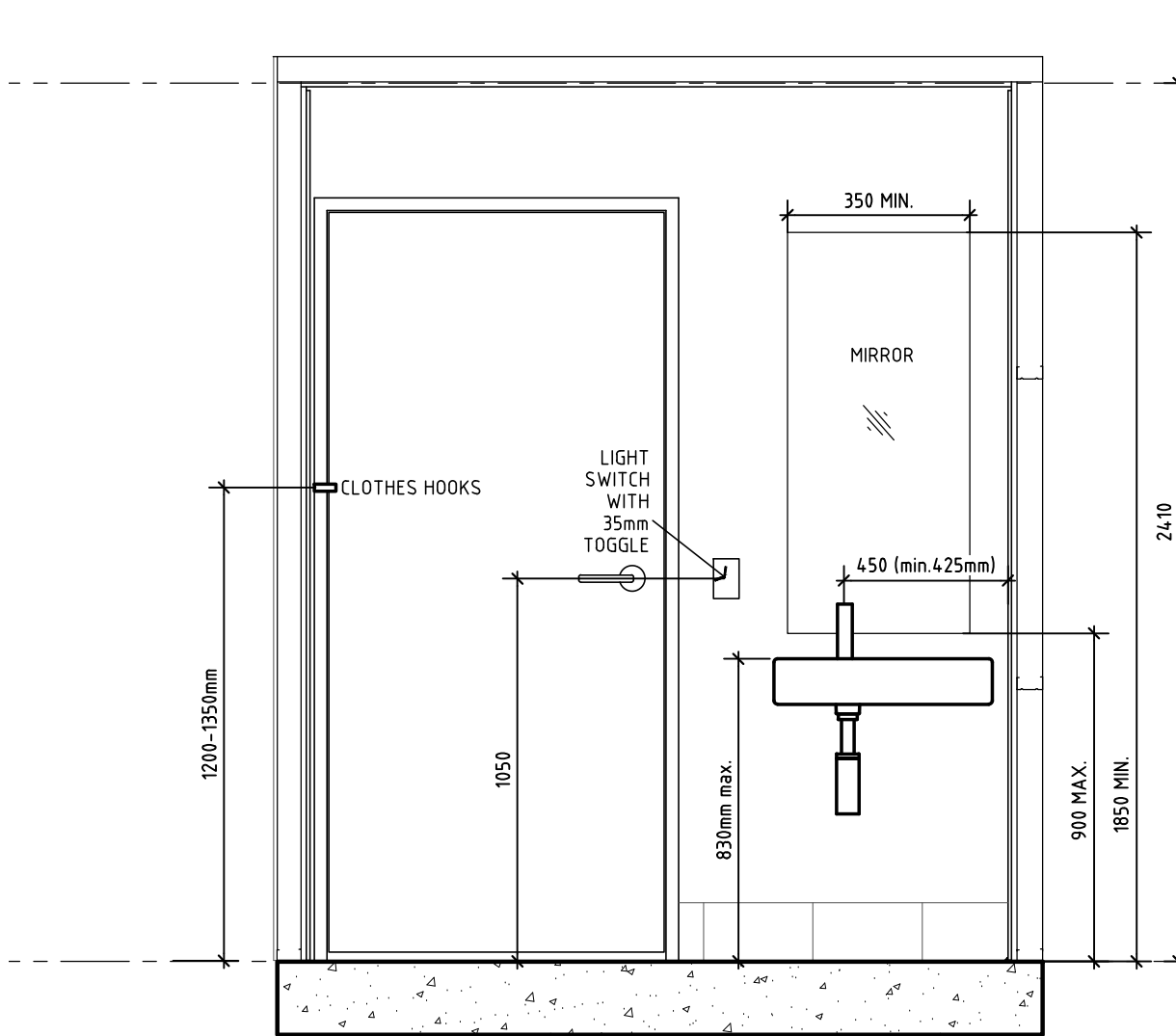

3 ELEVATION 3
SCALE 1:20 @ A3

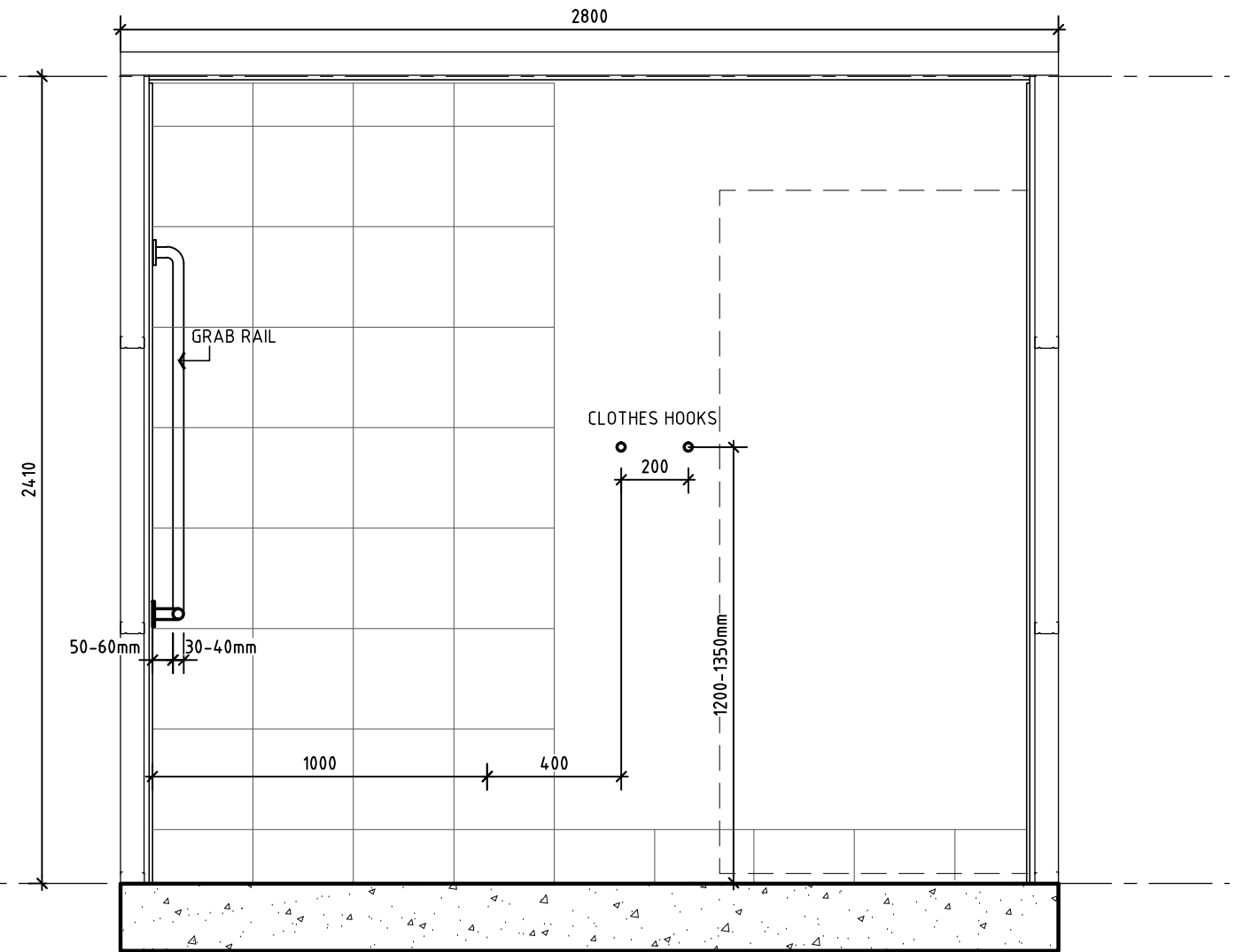

4 ELEVATION 4
SCALE 1:20 @ A3

These drawings & designs are the property of MJ Cassidy & Associates Pty. Limited and shall not be reproduced without explicit written consent of the owner

MJC
M.J.CASSIDY & ASSOC. PTY.LTD. 0437291376

VALLETTA HOMES

Ref.No. 2502_0476
Date FEB. 2025

Location LOT 19 IN DP
No.52 CEDAR MILL DR, JILLIBY NSW

Drawing BATHROOM ELEVATIONS

1	xx/xx/xx	ISSUED FOR APPROVAL
Rev.	Date	Description
Revision		A132
Scale 1:20 @ A3		

NOT FOR CONSTRUCTION

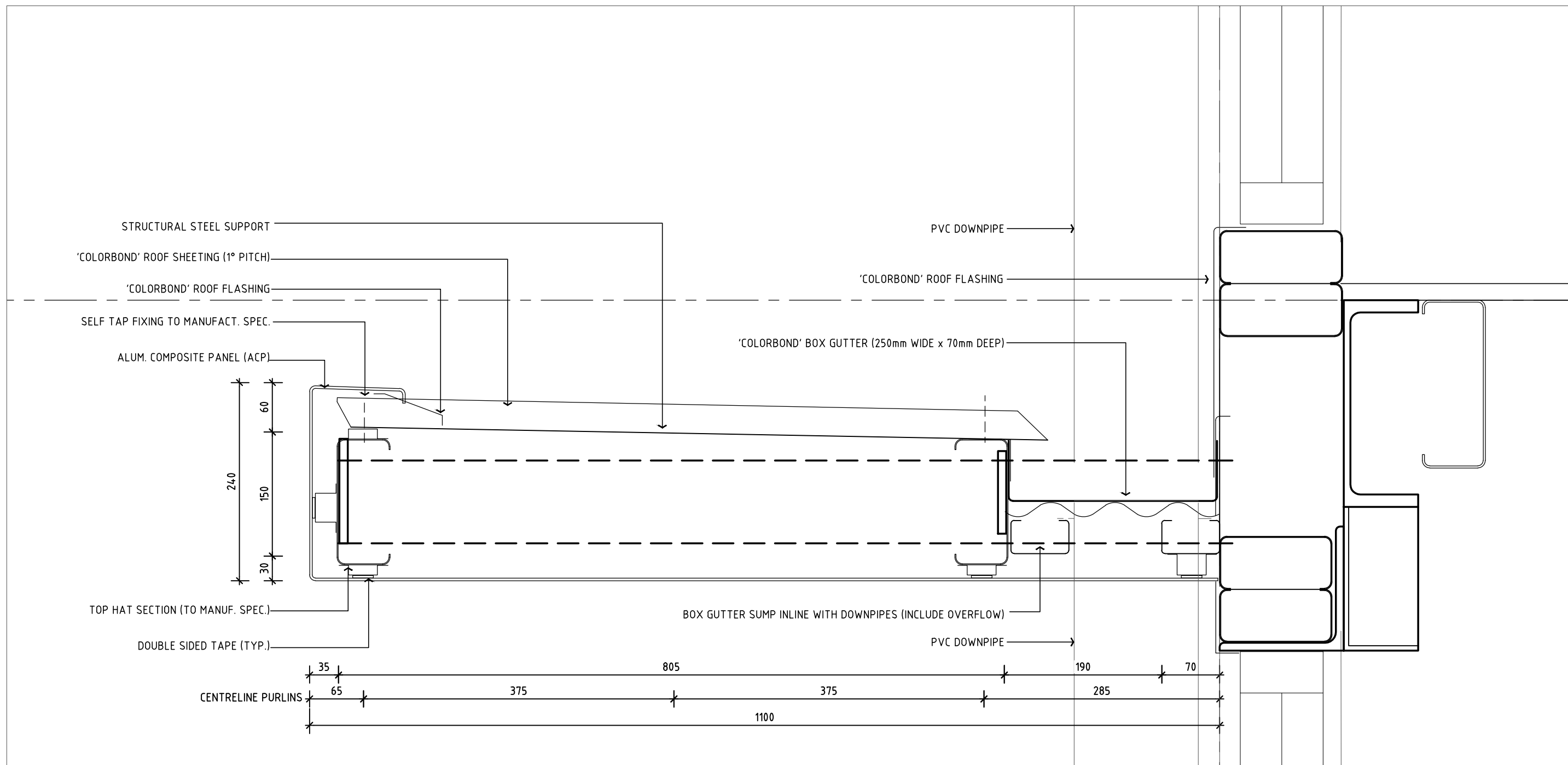

TYPICAL AWNING SECTION
SCALE 1:5 @ A3

NOTE
TO BE READ IN CONJUNCTION WITH THE STRUCTURAL ENGINEER'S DETAILS
AND THE DETAILED STEEL SHOP DRAWINGS.
ACP CLADDING AND WINDOW FIXING TO SUB-CONTRACTOR'S CONFIRMATION

1	xx/x/xx	ISSUED FOR APPROVAL
Rev.	Date	Description
Revision		A140
Scale AS SHOWN		

These drawings & designs are the property of MJ Cassidy & Associates Pty. Limited and shall not be reproduced without explicit written consent of the owner

MJC
M.J.CASSIDY & ASSOC. PTY.LTD. 0437291376

VALLETTA HOMES

Ref.No. 2502_0476
Date FEB. 2025

Location LOT 19 IN DP
No.52 CEDAR MILL DR, JILLIBY NSW

Drawing
AWNING DETAILS

NOT FOR CONSTRUCTION

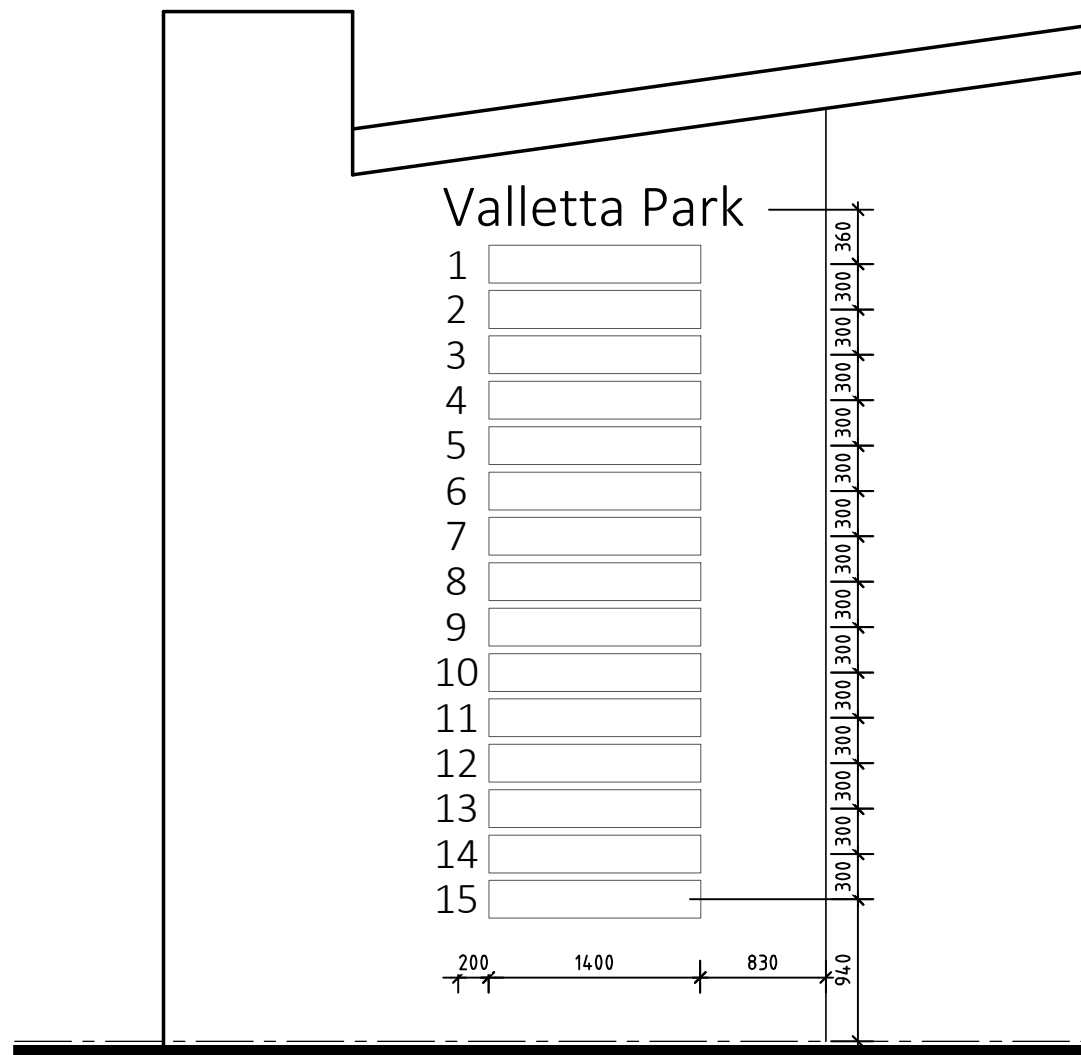

These drawings & designs are the property of MJ Cassidy & Associates Pty. Limited and shall not be reproduced without explicit written consent of the owner

MJC
M.J.CASSIDY & ASSOC. PTY.LTD. 0437291376

VALLETTA HOMES

Ref.No. 2502_0476
Date FEB. 2025

Location LOT 19 IN DP
No.52 CEDAR MILL DR, JILLIBY NSW

Drawing BUSINESS SIGNAGE

1	x/x/x	ISSUED FOR APPROVAL
Rev.	Date	Description
Revision		A150
Scale 1:50 @ A3		