



## HINCHINBROOK SHIRE COUNCIL

Our Ref: GV:HJR SR18\0012

03 December 2018

Mr DB Lawton  
39 Sheerwater Parade  
DOUGLAS QLD 4814

Email: [lawtondrafting@gmail.com](mailto:lawtondrafting@gmail.com)

Dear Sir

### **DECISION NOTICE** *Planning Act 2016*

In relation to your recent request for siting dispensation, Council have assessed your application and it was APPROVED SUBJECT TO CONDITIONS. The decision was made on Tuesday, 27 November 2018.

#### **APPLICATION DETAILS**

Application Number:	SR18\0012
Property ID Number:	103086
Applicant Details:	Bruce Lawton 39 Sheerwater Parade DOUGLAS QLD 4814
Owner Details:	Donald Bruce Lawton 39 Sheerwater Parade DOUGLAS QLD 4814
Property Description:	7 Barramundi Street, Taylors Beach, Queensland, 4850 Lot 80 on RP724089, Parish of Cordelia
Proposal:	Residential Siting Relaxation – Front Boundary Dispensation (6.0m building setback to 3m building setback)  Residential Siting Relaxation – Side Boundary Dispensation (1.5m building setback to 200mm building setback)

Level of Assessment: Code Assessment

### **DEEMED APPROVAL**

The application has not deemed to be approved under s.64 of the *Planning Act 2016*.

### **CONDITIONS OF APPROVAL**

The conditions of this approval are set out in the Schedule of Conditions. The conditions are identified to indicate whether the Assessment Manager or a referral agency (if any) imposed them.

### **REFERRAL AGENCIES**

Not Applicable

### **PROPERTY NOTES**

Not Applicable

### **FURTHER DEVELOPMENT PERMITS REQUIRED**

This approval does not authorise any filling of land or building work, and a development permit for carrying out any filling of land and/or building work must be obtained.

This approval also does not authorise any works within Council's Road Reserve (e.g. new/additional access, repair/modifications to existing access or works to footpaths), or any filling of land permits.

If this is required the relevant application will need to be lodged with Council or other relevant authority.

### **RIGHTS OF APPEAL**

You may appeal against any matter stated in the Decision Notice. Chapter 6, Part 1 and Part 2 of the *Planning Act 2016* detail appeal rights afforded to the applicant and submitter/s (if any) to the Planning and Environment Court or Building and Development Dispute Resolution Committee. Attached are the relevant provisions of the *Planning Act 2016* relating to the Rights of Appeal.

### **APPROVAL CURRENCY PERIOD**

All building works to be completed within two (2) years, commencing the date the decision is made, unless otherwise stated in the conditions of approval.

### **APPROVED PLANS & SPECIFICATIONS**

In accordance with the *Planning Act 2016*, a copy of the approved plans and specifications (if relevant) are attached.

### **FURTHER INFORMATION**

The development must be carried out in accordance with the approved plans and specifications and the requirements of all relevant laws, and any deviation there from must have the prior approval of the Chief Executive Officer.



Should you have any questions or seek clarification with regard to any aspect of this notice, I encourage you to contact Council's Development, Planning and Environmental Services on telephone 4776 4609.

Yours sincerely



Rosemary Pennisi  
Executive Manager Development, Planning and Environmental Services

Enclosed:      Approved Plans/Documents  
                    Appeal Rights



## **NOTICE ABOUT DECISION – STATEMENT OF REASONS**

### *PLANNING ACT 2016 & THE PLANNING REGULATION 2017*

This Notice is prepared in accordance with s.63(5) and s.83(7) of the *Planning Act 2016* to inform the public about a decision that has been made in relation to a development application. The purpose of the Notice is to enable a public understanding of the reasons for the planning decision, specifically having regard to:

- the relevant parts of the Planning Scheme and Assessment Benchmarks against which the application was assessed; and
- any other information, documents or other material Council was either required to, or able to, consider in its assessment.

All terms used in this Notice have the meanings given them in the *Planning Act 2016*.

### REASONS FOR THE DECISION

Council approve the front boundary siting relaxation from the permissible 6m to 3m and side boundary siting relaxation from the permissible 1.5m to 200mm, for the construction of an open carport extension on Lot 80 on RP724089 and located at 7 Barramundi Street, Taylors Beach, subject to conditions.

The reasons for approval are:

- The structure (open carport) will not obstruct daylight and ventilation to habitable rooms on the adjoining properties and will not impede on the privacy of neighbouring residences;
- The structure (open carport) is to be sited of a sufficient distance from the road frontage as not to impede on traffic or pedestrian safety and visibility;
- The structure (open carport) will not have an overshadowing effect on neighbouring residences;
- The structure (open carport) will not negatively impact the amenity of the adjoining land or the residential character of the locality; and
- Adjoining neighbours have consented to the residential siting relaxation for the structure.



**CONDITIONS OF APPROVAL**

Conditions	Compliance timing									
<b>Administration</b>										
<p>(1) The developer is responsible to carry out the approved development and comply with relevant requirements in accordance with:-</p> <ol style="list-style-type: none"> <li>The specifications, facts and circumstances as set out in the application submitted to Council, including recommendations and findings confirmed within the technical reports;</li> <li>The development must unless otherwise stated, be designed, constructed and maintained in accordance with the relevant Council policies, guidelines and standards</li> <li>The conditions of approval, the requirements of Council's Planning Scheme and best practice engineering.</li> </ol>	At all times									
<b>Currency Period</b>										
<p>(2) The currency period applicable to this approval.</p> <ul style="list-style-type: none"> <li>Siting Relaxation – Two (2) years until 5 December 2020</li> </ul>	As per condition									
<b>Approved plans</b>										
<p>(3) The development of the site is to be generally in accordance with the following plans that are to be the approved Plans of Development, except as altered by any other condition of this approval:</p> <table border="1"> <thead> <tr> <th>Plan / Document Name</th> <th>Number</th> <th>Date</th> </tr> </thead> <tbody> <tr> <td>Site Plan - Proposed construction</td> <td>-</td> <td>25/10/2018</td> </tr> <tr> <td>Proposed Car Port Proposed construction</td> <td>-</td> <td>25/10/2018</td> </tr> </tbody> </table>	Plan / Document Name	Number	Date	Site Plan - Proposed construction	-	25/10/2018	Proposed Car Port Proposed construction	-	25/10/2018	At all times
Plan / Document Name	Number	Date								
Site Plan - Proposed construction	-	25/10/2018								
Proposed Car Port Proposed construction	-	25/10/2018								
<p>(4) Where there is any conflict between the conditions of this approval and the details shown on the approved plans and documents, the conditions of approval must prevail.</p>	At all times									
<p>(5) Where conditions require the above plans or documents to be amended, the revised document(s) must be submitted for endorsement by Council prior to the submission of a Development Application for Operational Works</p>	As per condition									
<b>Lawful Point of Discharge</b>										
<p>(6) All stormwater from the property must be directed to a lawful point of discharge such that it does not adversely affect surrounding properties or properties downstream from the development, all to the requirements and satisfaction of the Chief Executive Officer.</p>	At all times									
<p>(7) The structure (open carport) must include guttering which directs all stormwater to a legal point of discharge within the confines of the boundary to which the attached dwelling resides.</p>	At all times									

Conditions	Compliance timing
<p><b>(8)</b> Where retaining walls, fences, buildings or other barriers, which would cause a “damming effect” and produce a concentrated flow at an outfall are constructed, a drainage system is installed to discharge the surface water such that it does not adversely affect surrounding properties or properties downstream from the development.</p>	At all times
<b>Building</b>	
<p><b>(9)</b> The class 10a (open carport) structure requires a development permit for building works.</p>	At all times
<p><b>(10)</b> The Applicant is to seek and comply with all relevant building approvals to be issued by a qualified Building Certifier</p>	At all times
<p><b>(11)</b> The class 10a (open carport) structure requires compliance to relevant Fire Safety regulations as reflected in s.3.7.1.6 of the Building Code of Australia (Volume Two).</p>	At all times
<b>Construction and Operations</b>	
<p><b>(12)</b> Any construction work associated with this development shall be carried out in accordance with sound engineering practice. In particular, no nuisance is to be caused to adjoining residents by way of smoke, dust, stormwater discharge or siltation of drains, at any time, including non-working hours. Where material is to be carted to or from the site, loads are to be covered to prevent dust or spillage. Where material is spilled or carried on to existing roads, it is to be removed forthwith so as to restrict dust nuisance and ensure traffic safety.</p>	At all times
<p><b>(13)</b> Any construction work associated with the access arrangements to the property from the road reserve is subject to a Private Works in a Road Reserve application and approval.</p>	Prior to any construction work commencing
<b>Damage to Infrastructure</b>	
<p><b>(14)</b> In the event that any part of Council’s existing sewer, water, channel and kerbing, or road infrastructure is damaged as a result of construction activities occurring on the site, including but not limited to, mobilisation of heavy earthmoving equipment, stripping and grubbing, the applicant/ owner must notify Council immediately of the affected infrastructure and have it repaired or replaced by Council, at the developer’s cost.</p>	At all times



APPROVED PLANS/DOCUMENTS

File Ref: SR18\0012

For visual purposes only



 Proposed Carport (6m x 7.9m)  
 Site Location



Data Sources & Acknowledgments

While every care is taken to ensure the accuracy of the data used on this map, the Council nor any data providers make no representation or warranty about its accuracy, reliability, completeness or suitability for any particular purpose and disclaims all responsibility and all liability for all expenses, losses, damages and costs which you might incur as a result of the data being provided or its omission in any way for any reason. Copyright Hinchinbrook Shire Council 2018

Geospatial information obtained from Department of Natural Resources and Mines is current as at 2018 and to accuracy 1:50,000. Copyright Department of Natural Resources and Mines 2018

"This map is not to be resold or re-made as part of a commercial product"



Application for Residential Siting Relaxation - Front/Side Boundary Dispensation (Donald Lawton)

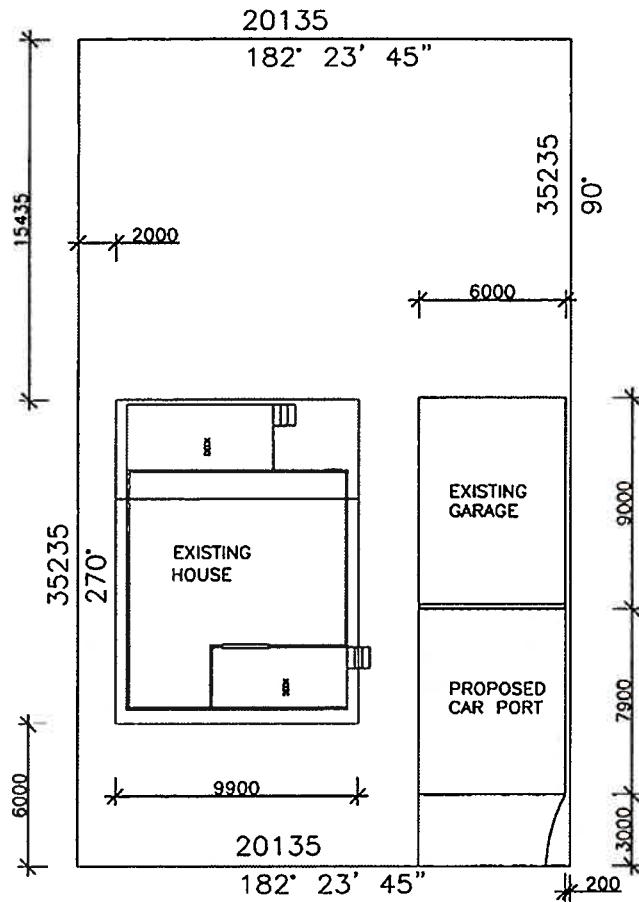

BARRAMUNDI STREET

**HINCHINBROOK SHIRE COUNCIL**

Residential Siting Relaxation  
**APPROVED**

*Rosemary Pennisi*

Rosemary Pennisi  
03 December 2018

SITE PLAN  
SCALE 1:200

REAL PROPERTY DESCRIPTION  
LOT 80 ON PLAN No 24089  
PARISH OF CORDELLIA  
COUNTY OF CARDWELL

ACKNOWLEDGEMENTS:  
DRAWN: OWNER    CHKD:  
DATE: 25/010/18

PROPOSED CONSTRUCTION FOR MR & MRS LAWTON,  
7 BARRAMUNDI STREET TAYLOR BEACH

TITLE: SITE PLAN

C2    DRAWING NUMBER: ONE

SCALE: 1:200    SHEET 1 OF 2



A3

ZONE	REF	REVISION	BY	CHK	DATE

All dimensions in MM unless otherwise stated.  
Linear and Angular tolerances as specified.  
Do Not Scale.



STEELWORK  
TO COMPLY WITH A.S. 4100 & A.S. 4800  
ALL STEELWORK TO BE PRIMED AND PAINTED  
ALL WELDS TO BE 6mm CONTINUOUS FILLET  
WELDS (CFW)

NOTE  
ALL WELDS TO BE COLD GALVANIZED COATED

TRUCK COLOUR RIBB ROOF SHEET  
FIXED TO MANUFACTURERS SPECIFICATIONS

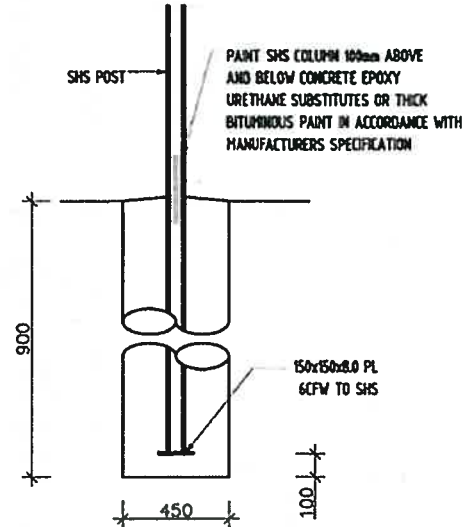
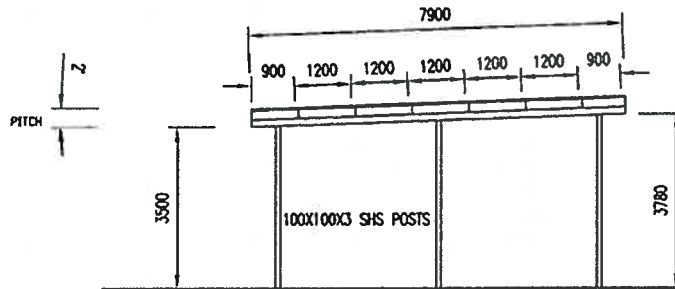

P1 FOOTING DETAIL  
SCALE 1:20

BRACING 30X1.0 CS50 GALV. STRAP  
2/No 14 TECK SCREW EACH END  
STANDARD CLEAT WELDED 6mm FILLET  
TO BEAM 2 M12 BOLTS TO C PURLINS

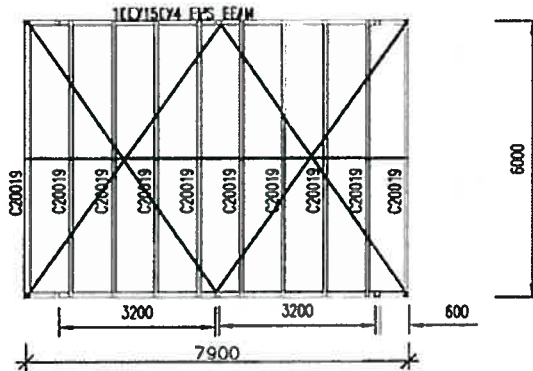

PURLIN LAYOUT PLAN  
SCALE 1:100

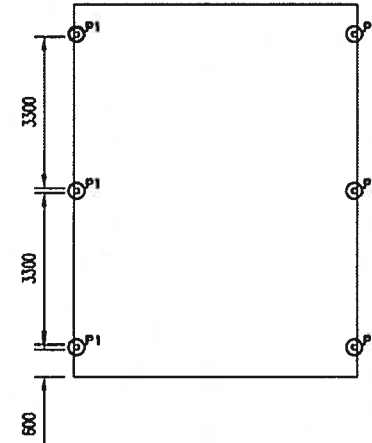

HINCHINBROOK SHIRE COUNCIL

Residential Siting Relaxation  
APPROVED

*Rosemary Pennisi*

Rosemary Pennisi  
03 December 2018

NOTES  
THIS DRAWING IS ONLY INTENDED TO OBTAIN A LOCAL  
AUTHORITY BUILDING PERMIT  
COMPLY WITH ALL RELEVANT AUTHORITY REG. AS A  
FIGURED DIMENSIONS TO TAKE PRECEDENCE OVER  
SCALE DIMENSIONS TO NOT SCALE DRAWING  
VERIFY ALL ON SITE DIMENSIONS & LEVELS PRIOR TO  
THE COMMENCEMENT OF ANY CONSTRUCTION

ZONE	REF	REVISION	BY	CHK	DATE

ACKNOWLEDGEMENTS:  
DRAWN: OWNER CHKD:  
DATE: 25/10/18

All dimensions in MM unless otherwise stated.  
Linear and Angular tolerances as specified.  
Do Not Scale.

PROPOSED CONSTRUCTION FOR MR & MRS LAWTON,  
7 BARRMUNDI STREET TAYLOR BEACH

TITLE:  
PROPOSED CAR PORT

C2 DRAWING NUMBER: ONE  
SCALE: 1:50 SHEET 2 OF 2



A3

**APPEAL RIGHTS***PLANNING ACT 2016 & THE PLANNING REGULATION 2017***Chapter 6 Dispute resolution****Part 1 Appeal rights****229 Appeals to tribunal or P&E Court**

- (1) Schedule 1 of the *Planning Act 2016* states –
- (a) Matters that may be appealed to –
    - (i) either a tribunal or the P&E Court; or
    - (ii) only a tribunal; or
    - (iii) only the P&E Court; and
  - (b) The person-
    - (i) who may appeal a matter (**the appellant**); and
    - (ii) who is a respondent in an appeal of the matter; and
    - (iii) who is a co-respondent in an appeal of the matter; and
    - (iv) who may elect to be a co-respondent in an appeal of the matter.

(Refer to Schedule 1 of the *Planning Act 2016*)

- (2) An appellant may start an appeal within the appeal period.
- (3) The **appeal period** is –
- (a) for an appeal by a building advisory agency – 10 business days after a decision notice for the decision is given to the agency; or
  - (b) for an appeal against a deemed refusal – at any time after the deemed refusal happens; or
  - (c) for an appeal against a decision of the Minister, under chapter 7, part 4, to register premises or to renew the registration of premises – 20 business days after a notice is published under section 269(3)(a) or (4); or
  - (d) for an appeal against an infrastructure charges notice – 20 business days after the infrastructure charges notice is given to the person; or
  - (e) for an appeal about a deemed approval of a development application for which a decision notice has not been given – 30 business days after the applicant gives the deemed approval notice to the assessment manager; or
  - (f) for any other appeal – 20 business days after a notice of the decision for the matter, including an enforcement notice, is given to the person.

*Note –*

*See the P&E Court Act for the court's power to extend the appeal period.*

- (4) Each respondent and co-respondent for an appeal may be heard in the appeal.
- (5) If an appeal is only about a referral agency's response, the assessment manager may apply to the tribunal or P&E Court to withdraw from the appeal.
- (6) To remove any doubt. It is declared that an appeal against an infrastructure charges notice must not be about-
- (a) the adopted charge itself; or
  - (b) for a decision about an offset or refund-
    - (i) the establishment cost of trunk infrastructure identified in a LGIP; or
    - (ii) the cost of infrastructure decided using the method included in the local government's charges resolution.

**230 Notice of appeal**

- (1) An appellant starts an appeal by lodging, with the registrar of the tribunal or P&E Court, a notice of appeal that-
- (a) is in the approved form; and
  - (b) succinctly states the grounds of the appeal.
- (2) The notice of appeal must be accompanied by the required fee.
- (3) The appellant or, for an appeal to a tribunal, the registrar must, within the service period, give a copy of the notice of appeal to –
- (a) the respondent for the appeal; and
  - (b) each co-respondent for the appeal; and
  - (c) for an appeal about a development application under schedule 1, table 1, item 1 – each principal submitter for the development application; and
  - (d) for an appeal about a change application under schedule 1, table 1, item 2 – each principal submitter for the change application; and
  - (e) each person who may elect to become a co-respondent for the appeal, other than an eligible submitter who is not a principal submitter in an appeal under paragraph (c) or (d); and
  - (f) for an appeal to the P&E Court – the chief executive; and
  - (g) for an appeal to a tribunal under another Act – any other person who the registrar considers appropriate.
- (4) The *service period* is –
- (a) if a submitter or advice agency started the appeal in the P&E Court – 2 business days after the appeal has started; or
  - (b) otherwise – 10 business days after the appeal is started.
- (5) A notice of appeal given to a person who may elect to be a co-respondent must state the effect of subsection (6).

- (6) A person elects to be a co-respondent by filing a notice of election, in the approved form, within 10 business days after the notice of appeal is given to the person.

#### 231 Other appeals

- (1) Subject to this chapter, schedule 1 and the P&E Court Act, unless the Supreme Court decides a decision or other matter under this Act is affected by jurisdictional error, the decision or matter is non-appealable.
- (2) The *Judicial Review Act 1991*, part 5 applies to the decision or matter to the extent it is affected by jurisdictional error.
- (3) A person who, but for subsection (1) could have made an application under the *Judicial Review Act 1991* in relation to the decision or matter, may apply under part 4 of that Act for a statement of reasons in relation to the decision or matter.
- (4) In this section –
- decision* includes–
- (a) conduct engaged in for the purpose of making a decision; and
  - (b) other conduct that relates to the making of a decision; and
  - (c) the making of a decision or failure to make a decision; and
  - (d) a purported decision ; and
  - (e) a deemed refusal.
- non-appealable*, for a decision or matter, means the decision or matter–
- (a) is final and conclusive; and
  - (b) may not be challenged, appealed against, reviewed, quashed, set aside or called into question in any other way under the *Judicial Review Act 1991* or otherwise, whether by the Supreme Court, another court, a tribunal or another entity; and
  - (c) is not subject to any declaratory, injunctive or other order of the Supreme Court, another court, a tribunal or another entity on any ground.

#### 232 Rules of the P&E Court

- (1) A person who is appealing to the P&E Court must comply with the rules of the court that apply to the appeal.
- (2) However, the P&E Court may hear and decide an appeal even if the person has not complied with the rules of the P&E Court.

