

# SPENCER

Australian designed  
& manufactured



## Spencer 3.5 seater

### Dimensions

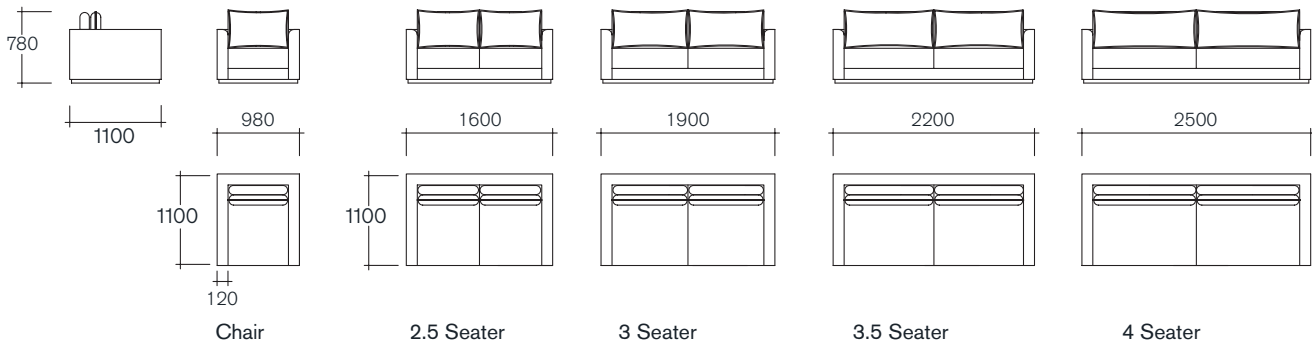

Available in alternative sizes, as a modular or with chaise.

### Specifications



<b>Materials</b> solid timber	<b>Insert</b> premium foam with dacron wrap or feather comfort wrap	<b>Upholstery</b> fabric, leather	<b>Guarantee</b> 10 year structural guarantee	<b>GECA certified manufacturer</b>
	<b>Leg</b> timber plinth	<b>Stain</b> various		

arthur**G**

arthurg.com.au  
sales@arthurg.com.au

**Head Office**  
1 Stafford Street  
Huntingdale  
Victoria 3166  
T+61 3 9543 4633

**Melbourne**  
618 Church Street  
Richmond  
Victoria 3121  
T+61 3 9429 6696

**Sydney**  
1/8 Hill Street  
Surry Hills 2010  
New South Wales  
T+61 2 9332 1488

**Perth**  
207 Stirling Hwy  
Claremont 6010  
Western Australia  
T+61 8 9286 1433

**Adelaide/Transforma**  
21 Kensington Road  
Norwood 5067  
South Australia  
T+61 8 8332 4044