



# Workstation Organiser

## Assembly Instructions

### 1. THE SHELL

Open out to form a cube.  
To make up the front of the cube first, fold flaps in the sequence shown, locking the long flaps into place last.

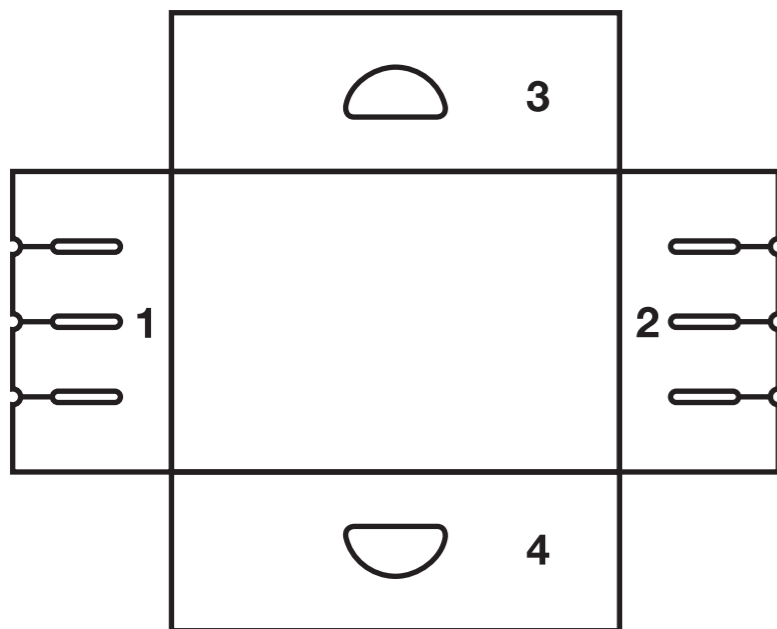

2. Turn cube over and carefully separate the perforations of the locking pieces on the base of the cube.

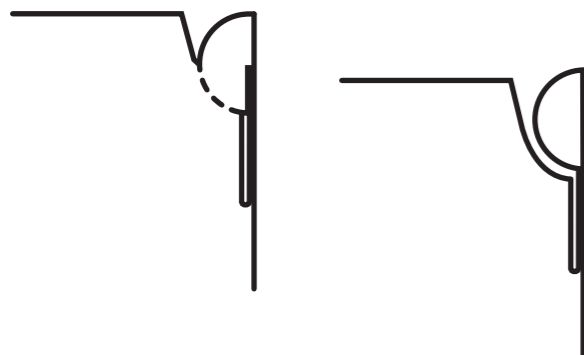

### 3. The shelves

Fold in half, ensuring the scores at the front of the shelf form a square edge as shown (A). Bend tabs as shown (B).

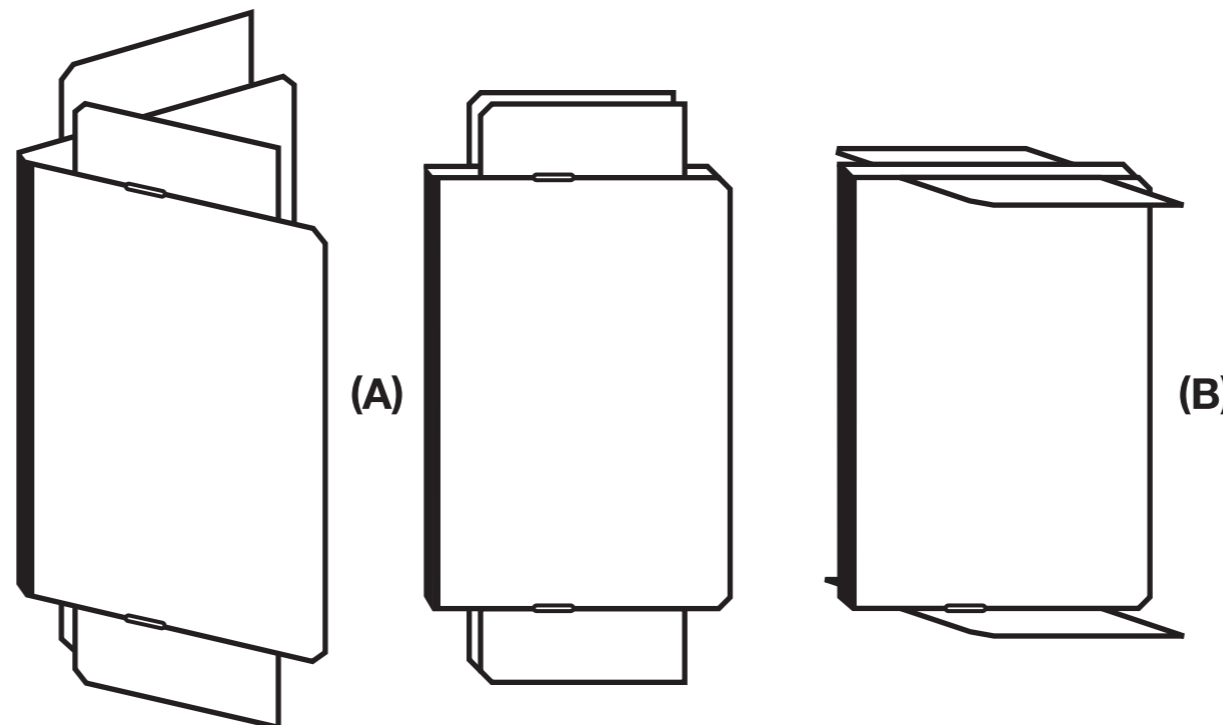

### 4. INSERTING SHELVES

Place the cube on a flat surface with the open base facing up. Insert the shelves from the base of the cube with the black end in first. Lift the flaps inside the front of the cube so that the flaps on the shelves are behind these. Push the shelf into place carefully (C). Repeat with the remaining shelves, inserting the middle shelf last.

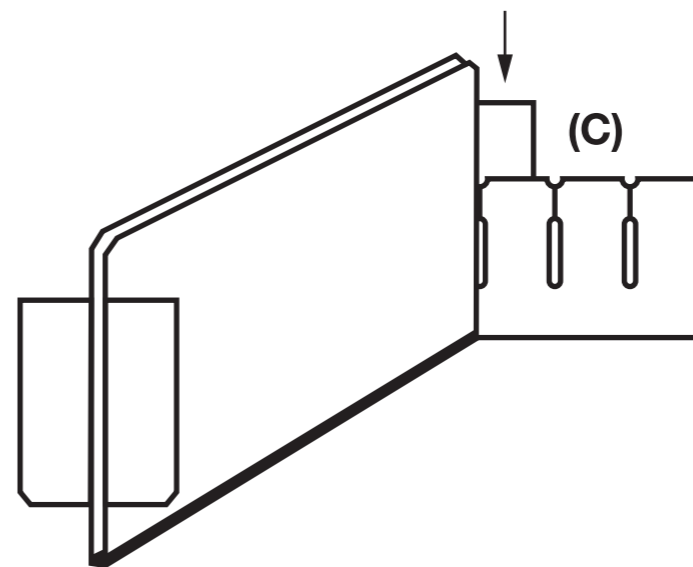

### 5. LOCKING BASE

Fold short flaps in first. To fold the long flaps in, first fold the score near the perforated locking pieces, outwards (D). Fold the flap in, inserting the locking pieces into the slots on the short side of the base (E).

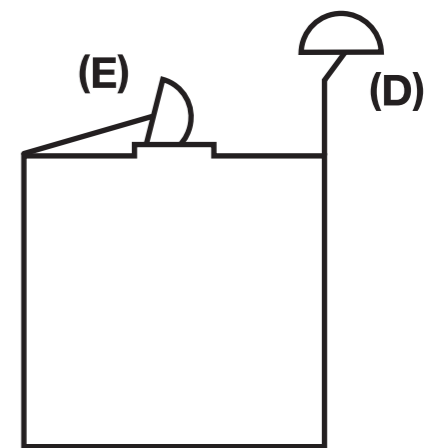

### 6. FINISHED WORKSTATION ORGANISER

