

OTTO

ASSEMBLY INSTRUCTIONS

OSLO LARGE 1500MM DESK

OTOSLODESK



This design and instruction booklet is subject to copyright.
www.officeworks.com.au

1 Carton

For spare parts or hardware call (03) 9310 3011 or email hardware@kyvas.com.au

Important

Estimated Assemble Time: 30min

- To view an assembly video, go to <https://www.officeworks.com.au/>
- Search the product by item code or name:

- Click on the icon to watch the video.



People Required



CAUTION
More Than One Person
Is Required To Safely
Assemble The Item

Customer Service Contact Details



HOTLINE
(03) 9310 3011

General Advice

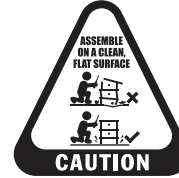

CAUTION
Assemble On A Clean
Flat Surface

Tools Required

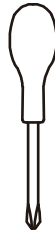

CAUTION: Do not use tools other than those required, as this can damage your new item.

NOTE

- Please check you have all hardware before assembling.
- If you are missing any hardware, please contact Kyvas on (03) 9310 3011 or email hardware@kyvas.com.au
- Please ensure you have the item, required hardware part and quantity.
- Please retain your receipt as proof of purchase to validate your warranty.

CAUTION

- Do not tighten screws before all screws are in the right place.
- Do not use this product unless all bolts, screws and knobs are firmly secured.
- Check that all bolts, screws and knobs are securely tightened at least every 4 months.

WARNING

- If parts are missing, broken, damaged or worn stop using the product until all repairs are made using manufacturer authorised parts.
- Keep children and animals away from the assembly area.
This furniture contains small parts that could cause choking if swallowed.
- Keep all plastic wrapping materials away from babies and children to avoid danger of suffocation.
- This item is not for outdoor use – unless stated otherwise.
- Failure to follow these warnings could result in serious injury.

DANGER

CHILDREN MUST BE SUPERVISED.

Part Overview

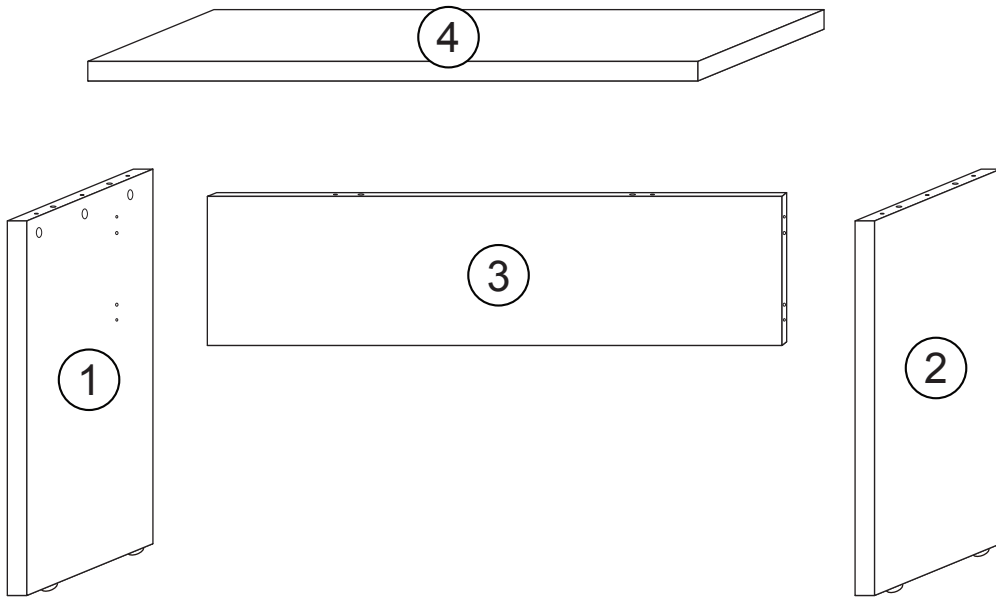

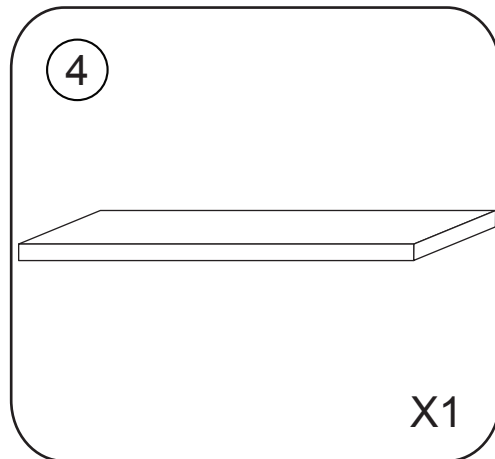
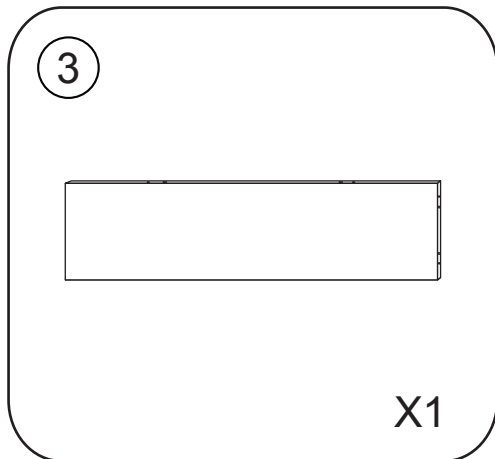
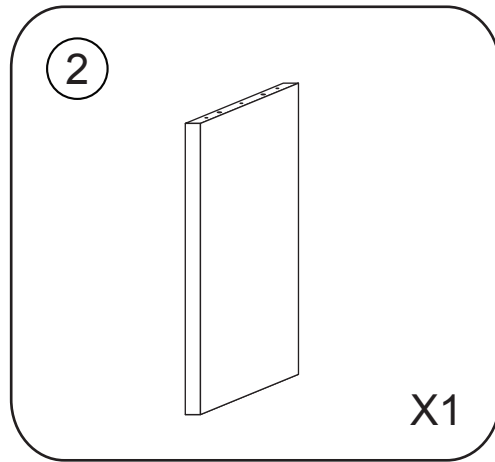
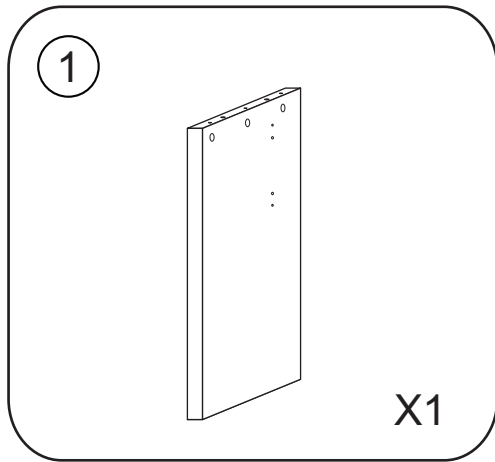

Part List

Parts located in Carton - OTOSLODESK

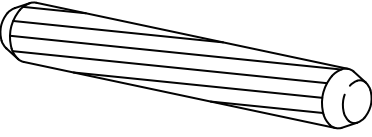

Hardware List

Hardware Pack located in Carton - OTOSLODESK

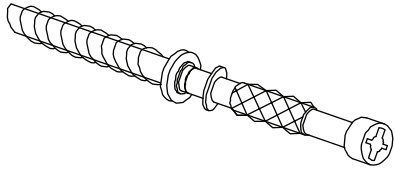
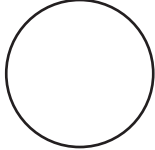
<p>A</p>  <p>(8 x 50mm) X 11pcs (extra 1pc)</p>	<p>B</p>  <p>(15 x 12mm) X 12pcs</p>	<p>C</p>  <p>(7 x 54mm) X 12pcs</p>
<p>D</p>  <p>Sticker X 12pcs</p>		

For missing hardware, please contact Kyvas on (03) 9310 3011 or email hardware@kyvas.com.au

Assembly

Step 1

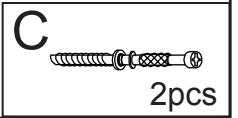
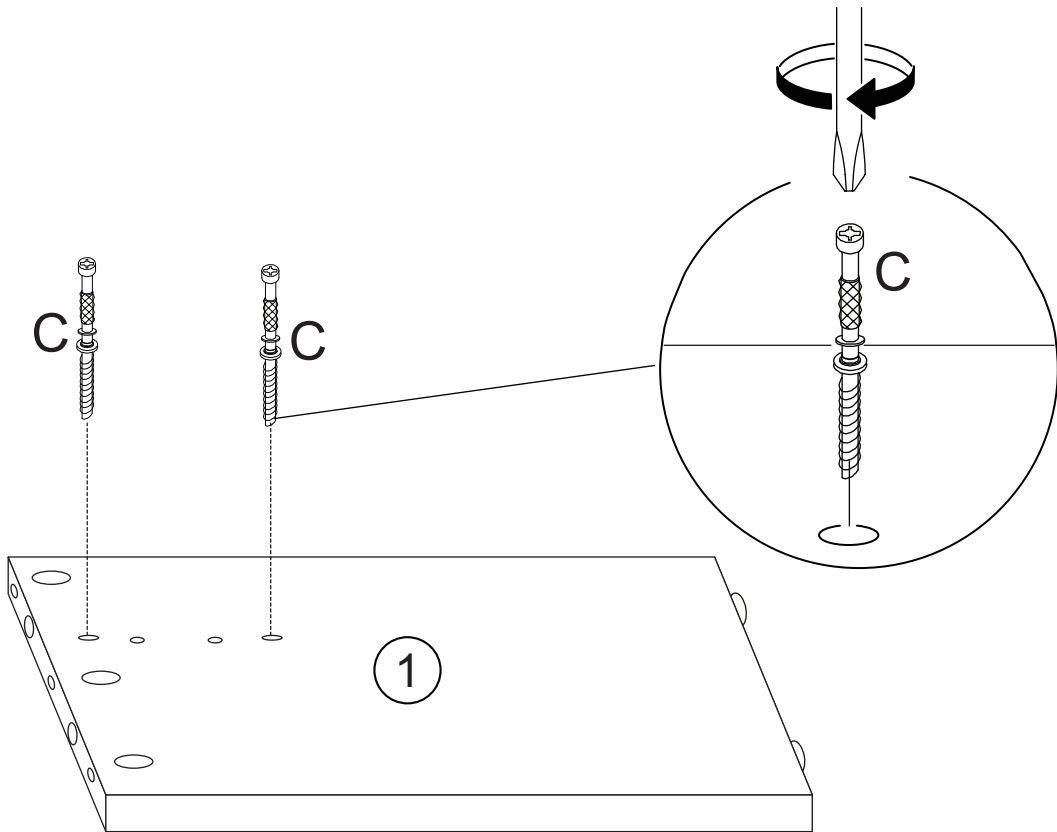

Step 2

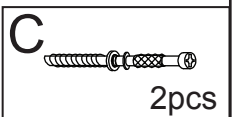
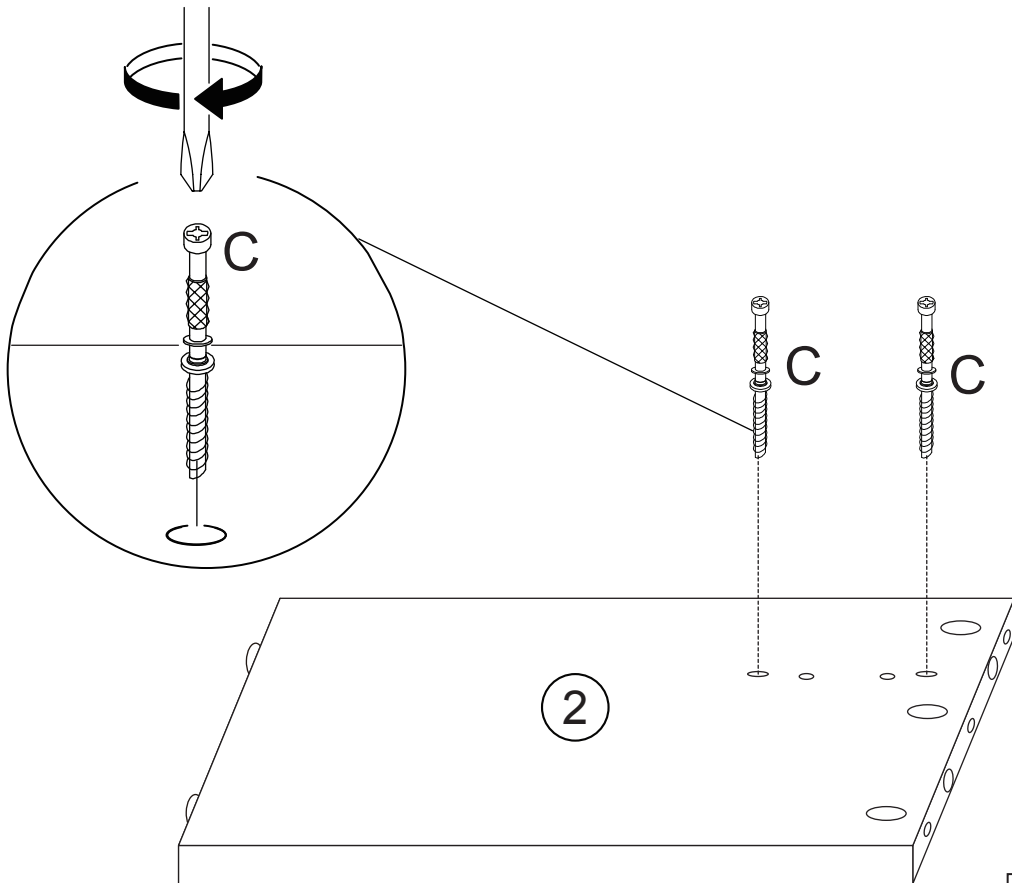

Step 3

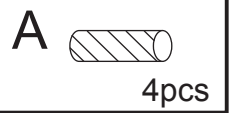
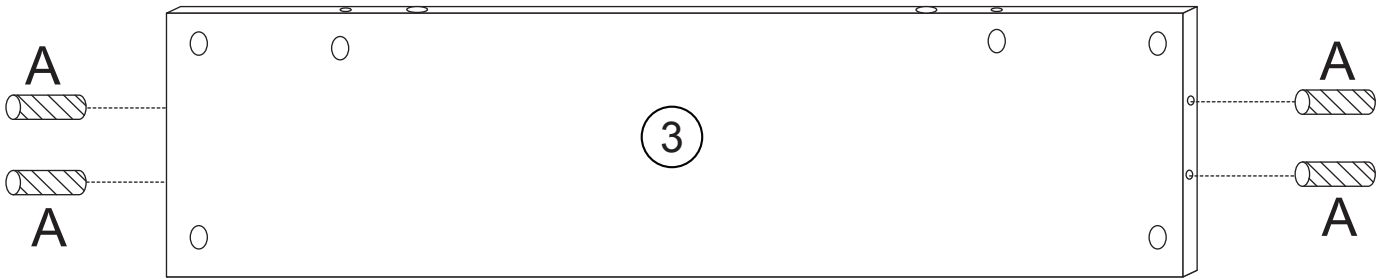

Step 4

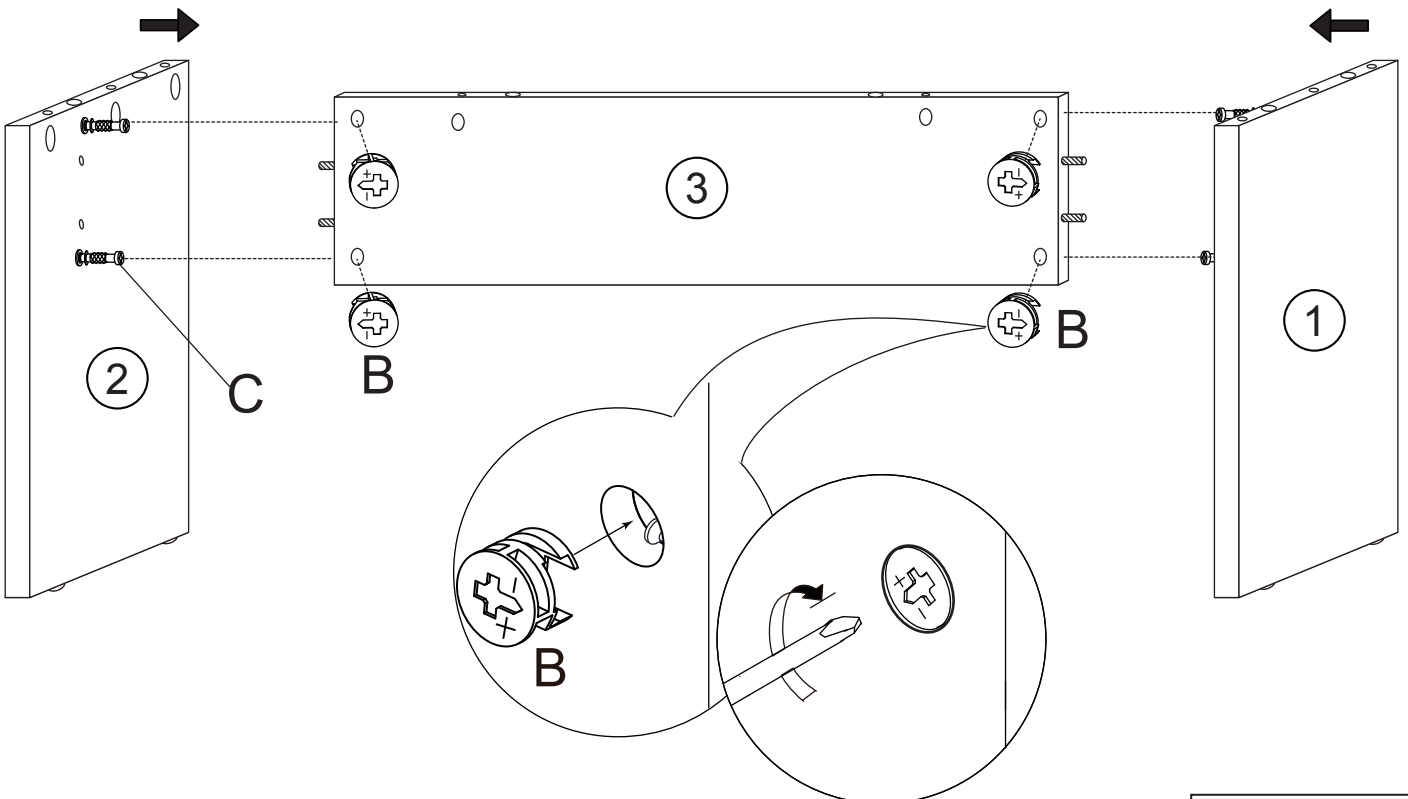

Tighten cam locks once panel (1) and (2) is in place.



Step 5

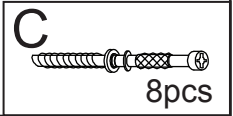
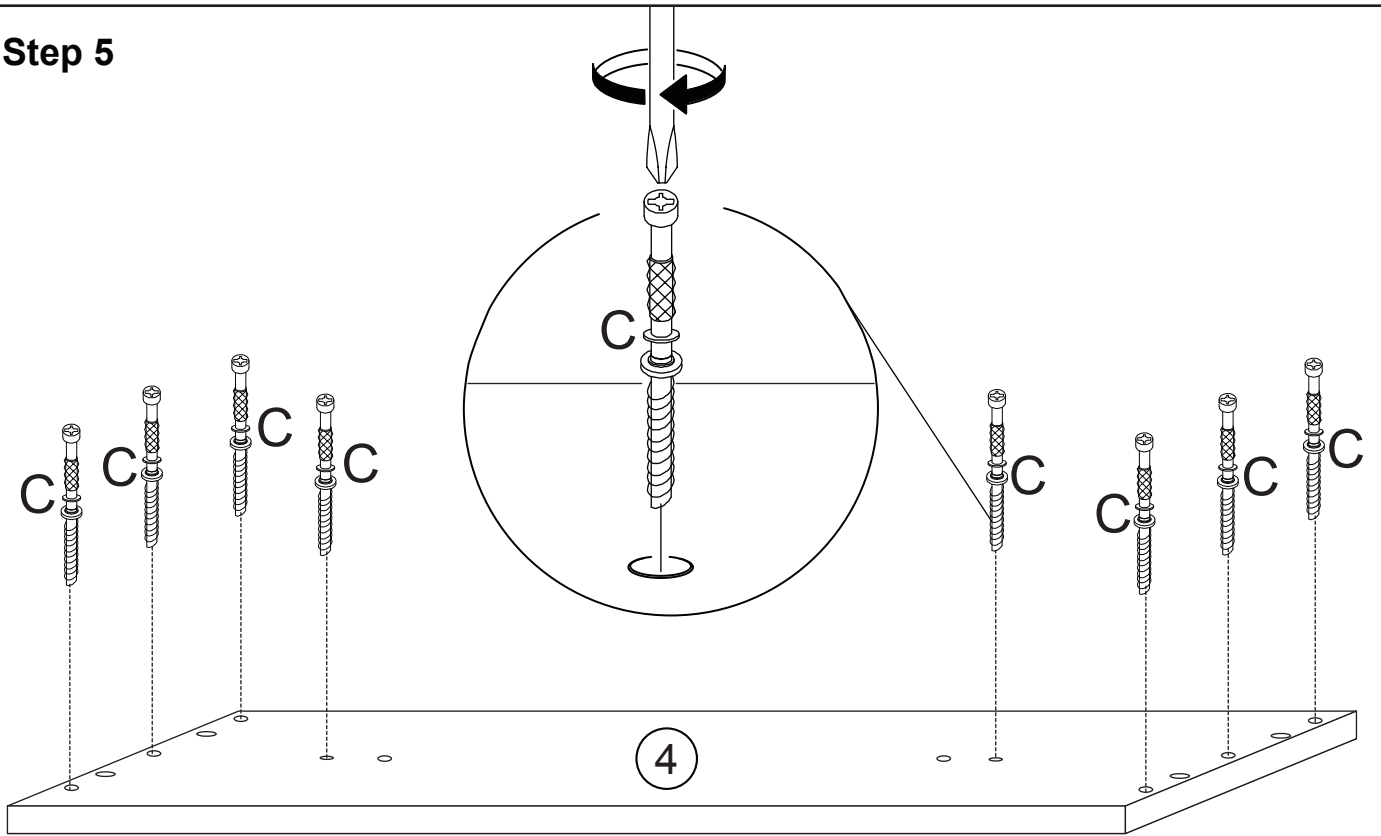

Step 6

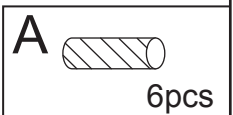
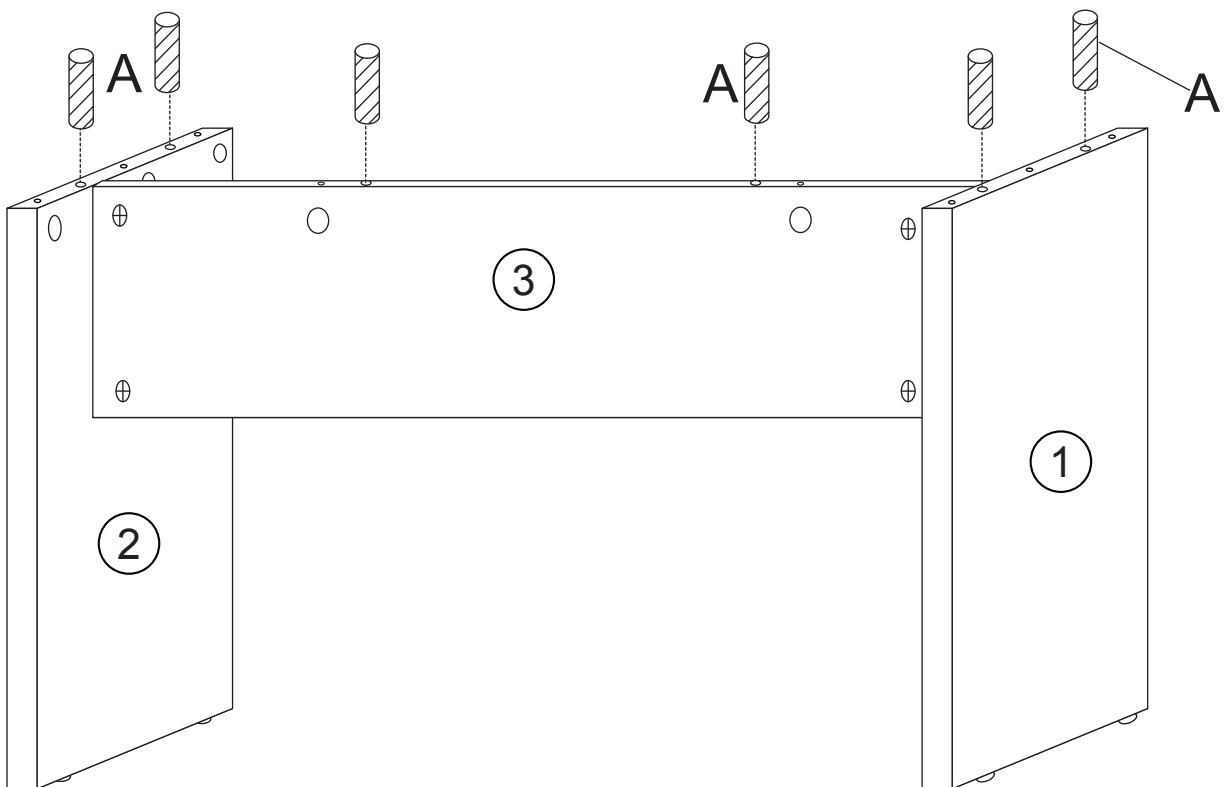

Step 7

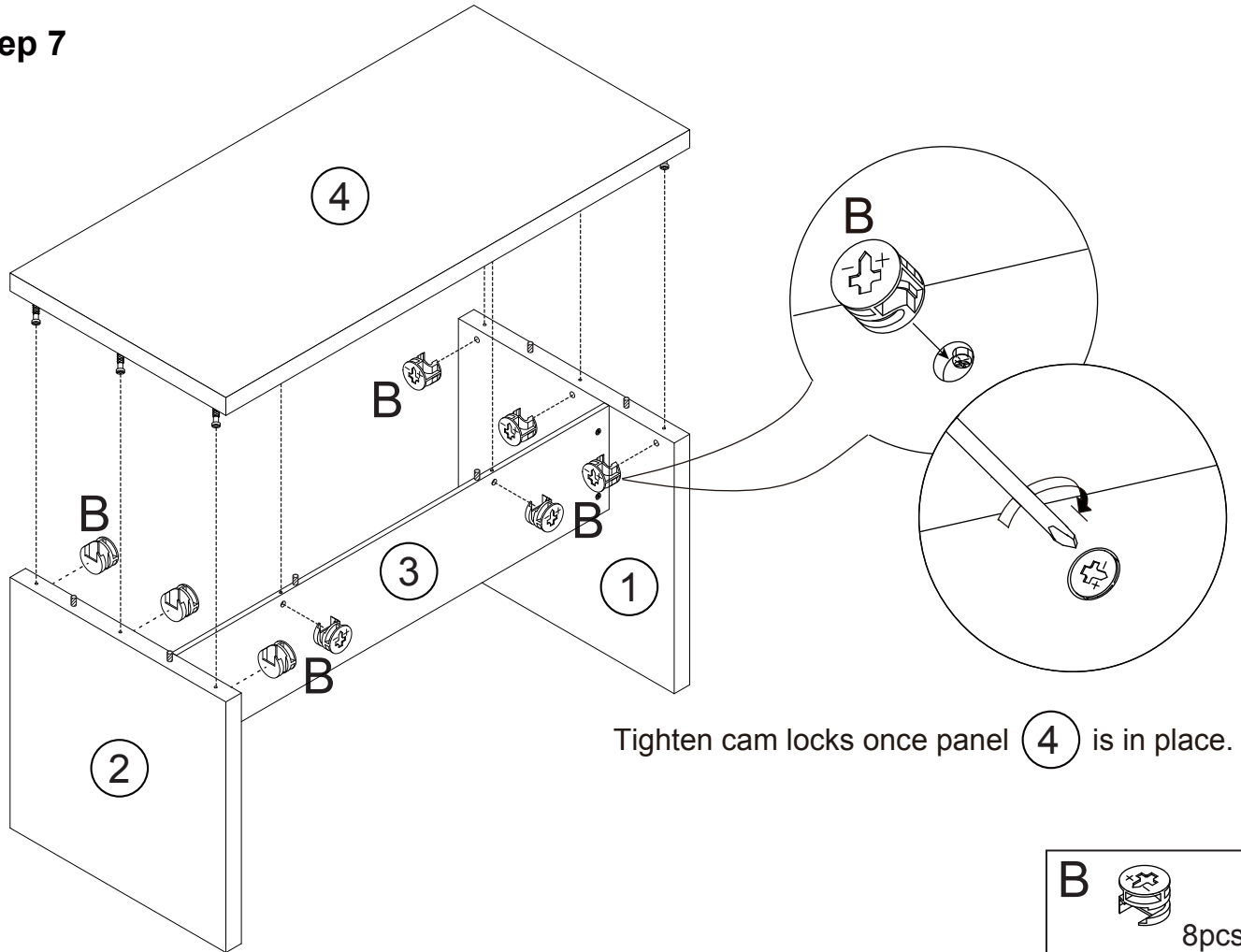

B  8pcs

Step 8

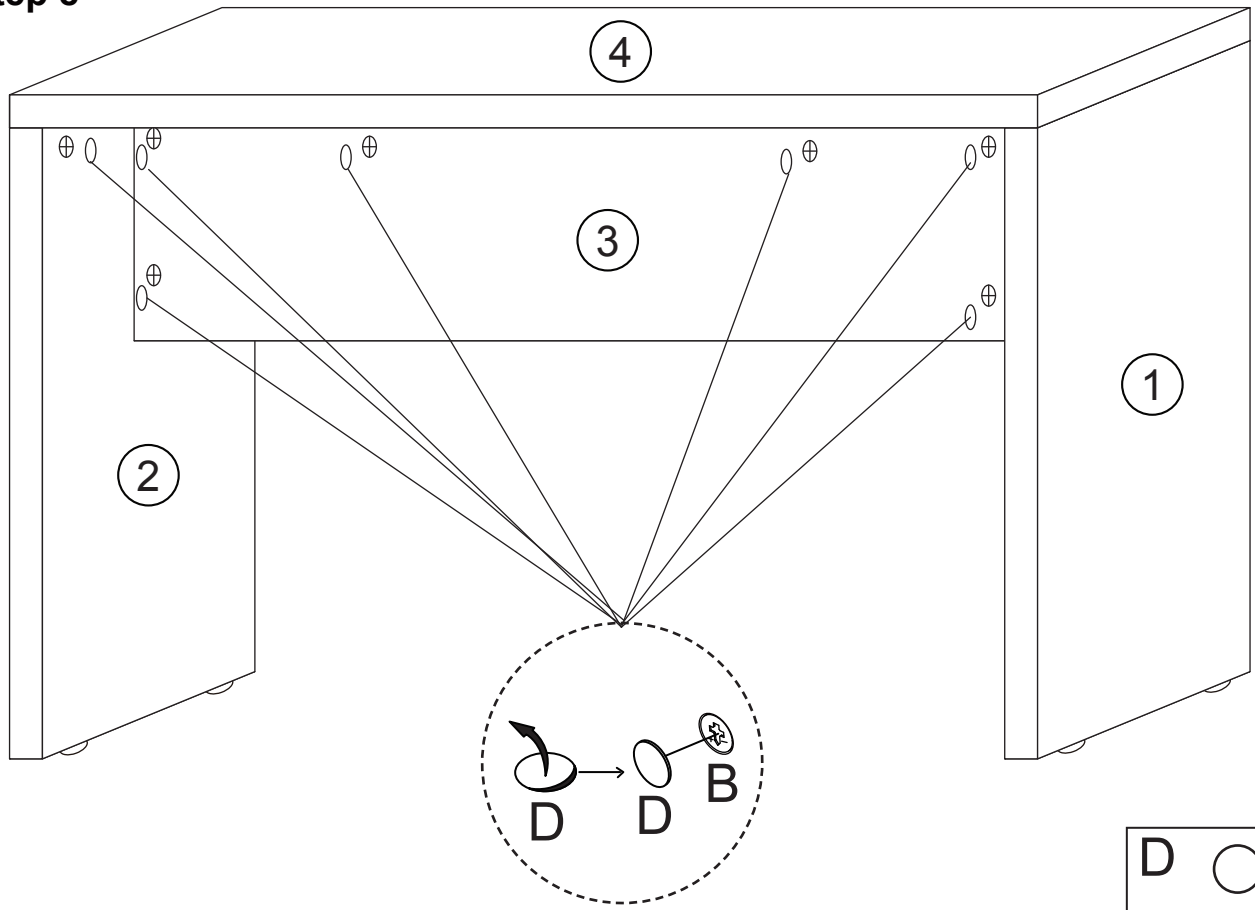

Maximum Load Capacity: 40kg



Your OSLO LARGE 1500MM DESK is now complete and ready for use

Care Advice

Care Instructions - PVC/ Melamine Finish Desk

- Keep away and protect from direct sunlight and heat.
- Do not place sharp materials(knife, fork, etc) directly onto your furniture as sharp material may scrape and damage the finish.
- Clean up spills quickly. Water left over a prolonged period of time may cause damage. Alcohol, perfume, nail polishes, aftershave and some medication may cause severe finish damage if not cleaned immediately.
- Use a clean, soft, dry, lint free absorbant cloth to clean your furniture. Do not use any detergent as they may contain ingredients that may react and damage the finish.
- Clean, check and tighten all parts regularly.

Safety Warning

- **CAUTION** – This product is intended to hold the maximum weight indicated. Exceeding the maximum weight will result in instability and may cause injury.

Warranty 3 years

Product Warranty – valid for Australian customers only

Officeworks Ltd warrants that this product will be free from defects and work as intended for 3 years from the date of purchase by the original customer.

If the product has any defects or does not work as intended during the Warranty Period, Officeworks will, at its election and at its expense, repair or replace the product.

This warranty does not apply:

- to cosmetic damage;
- to damage caused by consumables used in connection with the product (such as cleaning products);
- where the product has not been used in accordance with all provided instructions;
- to damage arising from fair wear and tear;
- where the product has not been subject to reasonable use;
- where the product has been intentionally or negligently damaged; and/or
- if the customer has attempted to repair the product.

To make a claim under this warranty, please return your product with your receipt or proof of purchase to your nearest Officeworks store or contact 1300 633 423.

This warranty is provided in addition to any rights you may be entitled to under the Competitions & Consumer Act 2010.

Our goods come with guarantees that cannot be excluded under the Australian Consumer Law. You are entitled to a replacement or refund for a major failure and compensation for any other reasonably foreseeable loss or damage. You are also entitled to have the goods repaired or replaced if the goods fail to be of acceptable quality and the failure does not amount to a major failure.



Thank you for your purchase. Please retain your receipt to validate warranty.
If you would like to know more about our furniture products, please visit www.officeworks.com.au