



Kestrel Defiant Roller Blind KR20T/F-KR22T/F KR41T/F

Fitting Instructions

KR20/22/41 - Roller Blinds

Fig 1.

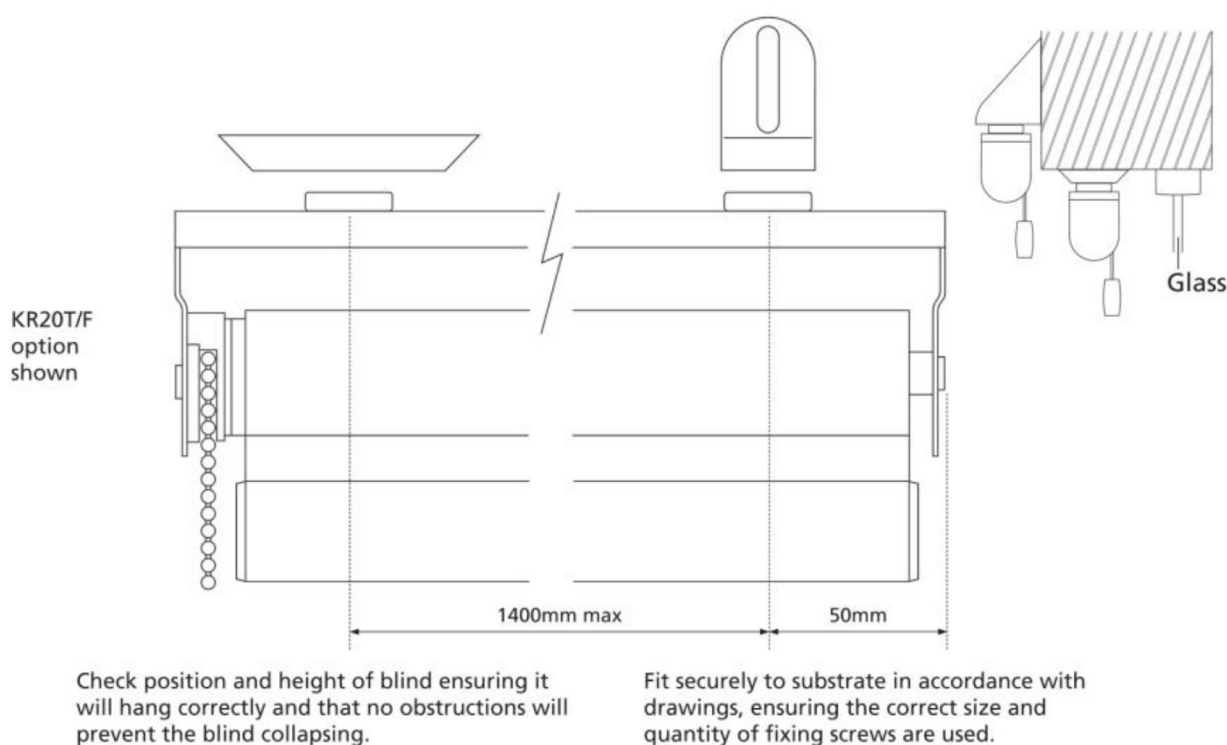

1. Check position and height of blind ensuring it will hang correctly and that no obstructions will prevent the blind collapsing.
2. Fit securely to substrate in accordance with drawings, Fig 1, ensuring the correct size and quantity of brackets are used.
3. Fix top or face brackets to ceiling or wall using suitable fixing screws/plugs as per shown below. It is important that the bracket is securely fixed to the substrate using TWO fixing screws and care must be taken to ensure that no ligature points are left once installation has been completed. If a degree of float is required in the magnet, the packing disc may be discarded.



K558PC

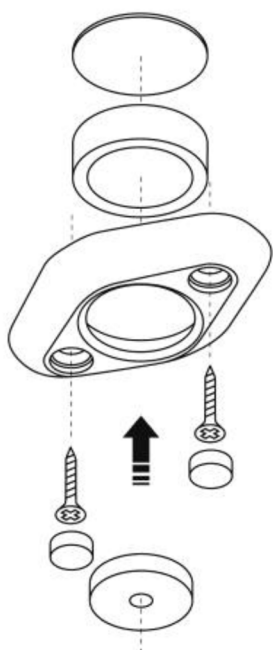

K555PC

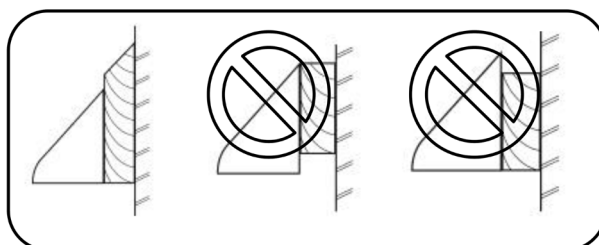
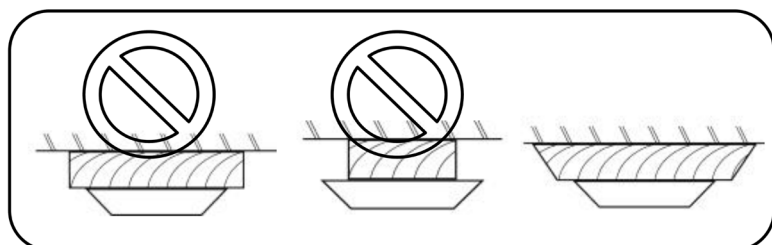
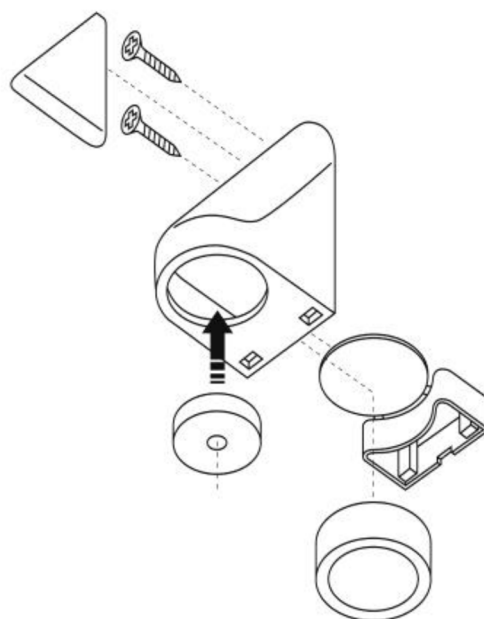

4. Lift blind into position.
5. Once blind is fitted and bracket positioning has been confirmed by testing, the push-in screw cover **MUST** be fitted ensuring that it is flush with the bracket body. The push-in screw cover is intended to be a tight fit to prevent unauthorised access to fixings.



ALL BRACKETS

Discs should be horizontal and centre of gravity of load should be directly beneath centre-line of discs. Test completed installation. The downward force needed to part the brackets should never be more than 400N [40kg static load] at any point.

WARNING

The magnetic element of the Kestrel bracket is **POWERFUL**. Handle with care. If allowed to attach to a flat steel surface it may be difficult to remove. **DO NOT PLACE NEAR SENSITIVE ELECTRONIC EQUIPMENT.**

ABOUT HIPAC

We are an Australian healthcare company that guarantees to stand behind all our medical products, both manufactured and imported, because we're here for the life of our products and clients.

PO Box 797, 36 Long St. Goulburn NSW 2580, Australia
P. +61 2 4823 0000 E. info@hipac.com.au

SYDNEY | MELBOURNE | BRISBANE | ADELAIDE | PERTH

hipac.com.au

ABN 27 600 353 688