

**SCAFFOLDING**  
**Basic to Advanced**



## Review Log

Version Number	Date Updated	Details of Updates	Reviewed by	Authorised By
1.0	11.06.2019	Created	Keith Finnie Todd Arnold Dorothy Kononen	Stewart Rizzi

## Copyright Notice

© Cape Australia Onshore Pty Ltd

All rights are reserved. No part of this work may be reproduced or copied in any form or by any means, electronic or mechanical, including photocopying, without the written permission of the publisher.

Any enquiry relating to these materials should be made to:

Cape Australia Onshore Pty Ltd  
39 Cutler Rd Jandakot WA 6164

Email

Atradservicesau.infotrain@capeplc.com

## Table of Contents

<b>PREFACE.....</b>	<b>7</b>
LEGAL OBLIGATIONS.....	7
DISCLAIMER.....	7
<b>INTRODUCTION.....</b>	<b>8</b>
<b>THE SCAFFOLDING BASICS.....</b>	<b>9</b>
<i>Parts of a Scaffold.....</i>	<i>9</i>
<i>Bays and Lifts.....</i>	<i>9</i>
TYPES OF SCAFFOLDING.....	9
<i>Basic Level Scaffolds.....</i>	<i>10</i>
<i>Intermediate Level Scaffolds.....</i>	<i>11</i>
<i>Advanced Level Scaffolds.....</i>	<i>13</i>
SCAFFOLD DUTY.....	13
<i>Scope and General.....</i>	<i>14</i>
IDENTIFY FORCES AND LOADS.....	14
<b>OCCUPATIONAL / WORK HEALTH &amp; SAFETY.....</b>	<b>15</b>
OHS/WHS REQUIREMENTS.....	15
<i>Harmonisation of Work Health &amp; Safety Legislation.....</i>	<i>15</i>
CONSULTATION AND COMMUNICATING WITH OTHERS.....	16
IDENTIFY AND CONTROL HAZARDS.....	16
WORKING NEAR POWER LINES.....	18
<i>State Distance Information.....</i>	<i>18</i>
<i>Tiger Tails.....</i>	<i>20</i>
TASK-RELATED HAZARDS.....	20
RISK ASSESSMENT.....	21
<i>Risk Analysis.....</i>	<i>21</i>
<i>Risk Evaluation.....</i>	<i>22</i>
RISK & HAZARD CONTROLS.....	23
<i>Hierarchy of Controls.....</i>	<i>23</i>
<b>PREPARE A SCAFFOLDING PLAN.....</b>	<b>23</b>
<b>IDENTIFY, SELECT AND INSPECT EQUIPMENT.....</b>	<b>24</b>
SCAFFOLD BASIC LEVEL EQUIPMENT.....	25
<i>Footings.....</i>	<i>25</i>
<i>Scaffold Tubes.....</i>	<i>25</i>
<i>Scaffold Planks.....</i>	<i>26</i>
<i>Ladders.....</i>	<i>26</i>
<i>Tie Tubes.....</i>	<i>27</i>
<i>Gin Wheels.....</i>	<i>27</i>
<i>Static Safety Lines.....</i>	<i>27</i>
<i>Safety Nets.....</i>	<i>28</i>
SCAFFOLD INTERMEDIATE LEVEL EQUIPMENT.....	29
<i>Couplers and Fittings.....</i>	<i>29</i>

<b>ASSOCIATED EQUIPMENT .....</b>	<b>29</b>
SCAFFOLD BASIC LEVEL EQUIPMENT .....	29
<i>Screening</i> .....	29
<i>Adjustable Props</i> .....	29
<i>Scaffold Belts and Hand Tools</i> .....	29
<i>Materials Hoists</i> .....	30
SCAFFOLD INTERMEDIATE LEVEL EQUIPMENT .....	30
<i>Mast-climbing Work Platforms</i> .....	30
<i>Cantilevered Crane Loading Platforms</i> .....	31
<i>Prefabricated Needles &amp; Counterweights</i> .....	31
<i>Flexible Steel Wire Rope (FSWR)</i> .....	31
SCAFFOLD ADVANCED LEVEL EQUIPMENT (INCLUDING RIGGING EQUIPMENT) .....	39
<i>Beam Clamps</i> .....	39
<i>Beam Trolleys</i> .....	39
<i>Synthetic Slings</i> .....	39
<i>Chain Slings</i> .....	41
<i>Sling Arrangements and Sling Factors</i> .....	48
<i>Shackles</i> .....	49
<b>IDENTIFY SAFETY EQUIPMENT REQUIREMENTS .....</b>	<b>52</b>
VARIOUS SAFETY EQUIPMENT .....	52
<i>Safety Harnesses</i> .....	52
<i>Lanyards and Energy Absorbers</i> .....	53
<i>Inertia Reels</i> .....	53
ISOLATE DEFECTIVE EQUIPMENT .....	54
<b>SETTING UP FOR THE TASK.....</b>	<b>55</b>
CHECK GROUND SUITABILITY AND LOAD LIMITS FOR STRUCTURES .....	55
FIT SAFETY EQUIPMENT .....	56
PREPARE AND POSITION SCAFFOLDING EQUIPMENT.....	56
<b>ERECTING SCAFFOLD.....</b>	<b>57</b>
WORK SAFELY AT HEIGHTS .....	57
SCAFFOLD BASIC LEVEL .....	58
<i>Erecting A Scaffold</i> .....	58
SCAFFOLD INTERMEDIATE LEVEL .....	59
<i>Scaffold Task Requirements</i> .....	59
<i>Scaffold Drawings</i> .....	62
<i>Erecting A Tube and Fitting Scaffold</i> .....	65
<i>Platform Requirements</i> .....	67
<i>Erecting A Spurred Scaffold</i> .....	67
<i>Erecting A Barrow Ramp or Sloping Platform</i> .....	68
SCAFFOLD ADVANCED LEVEL .....	69
<i>Erecting A Hung (Tube and Fitting) Scaffold</i> .....	69
<i>Suspended Scaffolds</i> .....	73
<b>ERECTING SCAFFOLD EQUIPMENT .....</b>	<b>84</b>
SCAFFOLD - ALL LEVELS.....	84
<i>Installing A Static Line</i> .....	84
<i>Anchor Points</i> .....	84

SCAFFOLD BASIC LEVEL .....	86
<i>Installing a Materials Hoist</i> .....	86
<i>Scaffold Work Platform Requirements</i> .....	87
<i>Platform Brackets</i> .....	87
<i>Tank Brackets</i> .....	88
<i>Guardrail and Edge Protection Requirements</i> .....	88
<i>Installing Ladder Access</i> .....	89
<i>Bracing and Ties</i> .....	89
<i>Tie Examples</i> .....	91
SCAFFOLD INTERMEDIATE LEVEL .....	94
<i>Cantilevered Scaffold</i> .....	94
<i>Erecting A Cantilevered Scaffold</i> .....	94
<i>Cantilevered Crane Loading Platforms (CCLP)</i> .....	96
<i>Installing A Cantilevered Crane Loading Platform</i> .....	96
<i>Relocating a Cantilevered Crane Loading Platform</i> .....	98
<i>Safe Use of a Cantilevered Crane Loading Platform</i> .....	99
<i>Installing Perimeter Safety Screens and Shutters</i> .....	100
<i>Setting Up A Mast Climber</i> .....	101
<i>Putlogs</i> .....	102
<i>Toe boards</i> .....	103
<i>Catch Platforms</i> .....	103
<i>Access and Egress</i> .....	103
<i>Standards</i> .....	103
<i>Ledgers, Joints and Transoms</i> .....	104
<b>INSPECTION AND MAINTENANCE OF SCAFFOLDS.....</b>	<b>105</b>
MODIFYING OR INSPECTING A SCAFFOLD .....	105
COMPLETING A HANDOVER CERTIFICATE .....	106
<b>ACCIDENTS AND INCIDENTS .....</b>	<b>106</b>
INCIDENTS RELATING TO THE USE OF FALL ARREST SYSTEMS .....	106
<i>Suspension Trauma</i> .....	107
<i>Preventing Suspension Trauma</i> .....	107
<i>First Aid for Suspension Trauma</i> .....	108
<b>CONCLUDE SCAFFOLDING OPERATIONS.....</b>	<b>108</b>
TIDY THE WORK AREA .....	108
<i>Isolate Faulty Equipment and Report Defects</i> .....	108
REMOVE HAZARD CONTROL MEASURES.....	108
<b>APPENDIX A – OCCUPATIONAL/WORK HEALTH &amp; SAFETY COMMON TERMS AND DEFINITIONS .....</b>	<b>109</b>
<b>APPENDIX B – SCAFFOLDING COMMON TERMS AND DEFINITIONS.....</b>	<b>110</b>
<b>APPENDIX C – REFERENCED DOCUMENTS INFORMATION.....</b>	<b>115</b>
<b>APPENDIX D – EXCERPTS FROM THE STANDARDS .....</b>	<b>116</b>
SCAFFOLD BASIC LEVEL .....	116
SCAFFOLD INTERMEDIATE LEVEL .....	118
SCAFFOLD ADVANCED LEVEL .....	120
<b>APPENDIX E - HARNESS INSPECTION CHECKLIST.....</b>	<b>121</b>
<b>APPENDIX F – HANDOVER CERTIFICATE .....</b>	<b>122</b>

---

<b>APPENDIX G – SUPPLEMENTARY INFORMATION .....</b>	<b>123</b>
INCREASED FIRST LIFT HEIGHT .....	123
SPUR SCAFFOLDS .....	124
AS/NZS 1576.6: 2000 5.4 SLOPING WORKING PLATFORMS .....	126
RAMPS .....	127
CANTILEVERED CATCH PLATFORM (FAN) .....	128
CANTILEVERED SCAFFOLDS .....	129

## Preface

This study guide has been developed to serve as 'Refresher' tool for Candidates who already hold the High-Risk Work Licence for the units, and are required to undertake a Verification of Competence (VOC) for the HRW classification. The information contained may assist with completing the Theory component of the VOC.

## Legal Obligations

Cape Australia Onshore Pty Ltd will at all times abide by the principles of access and equity to persons regardless of cultural background, gender, sexuality, disability or age. Cape Australia Onshore Pty Ltd shall endeavour to solve all matters of appeal, grievance or complaint nature to a satisfactory conclusion and have an established process for complaints and appeals.

If required, Cape Australia Onshore Pty Ltd shall provide a service to support the language, literacy and numeracy skills of a participant and shall provide a flexible learning strategy to suit the participant's specific needs.

Cape Australia Onshore Pty Ltd will at all time when engaged in assessment practices, conduct assessments to the Australian Skills Quality Authority (ASQA) standards. Additionally, these assessments shall be of a high quality to satisfy the requirements of the relevant training packages and the level of competence expected within the relevant industry domain.

Cape Australia Onshore Pty Ltd, applies the principles of assessment based on the 'rules of evidence' - validity, reliability, fairness and flexibility.

All forms and policies shall be made available through the course Facilitator or Cape Australia Onshore Pty Ltd, Management upon request for the perusal of the course participant.

Comments or suggestions for the improvement of this Training Manual are welcomed and made in writing.

## Disclaimer

This study guide provides information to those who have previously achieved competence in the High Risk Work Licence Unit, however are required to undertake a Verification of Competence (VOC) and may need revision in areas of learning.

The guide was developed by Cape Australia Onshore Pty Ltd, and while every effort has been made to ensure that these materials are accurate, Cape Australia Onshore Pty Ltd accepts no responsibility for loss or damage resulting from any omissions or inaccuracies.

## Introduction

A scaffold (HRWL) is needed where working platforms are at a height where a person or object could fall more than 4 metres.

There are three certificate levels involved in scaffolding:

- ▶ Basic scaffolding
- ▶ Intermediate scaffolding
- ▶ Advanced scaffolding

This guide outlines the competency based skills needed to carry out basic, intermediate and advanced scaffolding safely.

### Basic Scaffolding

Those qualified in basic scaffolding must know how to carry out work associated with:

- ▶ Erection, alteration and dismantling of modular and prefabricated scaffolds
- ▶ Erection of cantilevered materials hoists with a maximum working load limit of 500 kilograms
- ▶ Installation and use of ropes and gin wheels
- ▶ Installation of safety nets
- ▶ Installation and use of static lines
- ▶ Erection of bracket scaffolds (tank and formwork)

While a person with a basic level scaffold HRWL is not allowed to erect tube and coupler or more advanced scaffolds (hung and suspended), they are allowed to use tube and coupler components for the following purposes:

- ▶ Ties
- ▶ Internal ledger bracing
- ▶ Handrails
- ▶ Mid-rails
- ▶ Security of toe boards/kickboards
- ▶ Installation and security of gin wheels



### Intermediate Scaffolding

Those qualified in intermediate scaffolding must know how to carry out work associated with all basic scaffolding competencies and:

- ▶ Erection, alteration and dismantling of tube and coupler scaffolds including tube and coupler covered ways and gantries
- ▶ Erection and dismantling of cantilevered and spurred scaffolds
- ▶ Erection and dismantling of barrow ramps and sloping platforms
- ▶ Installation of cantilevered crane loading platforms
- ▶ Erection and dismantling of mast climbers
- ▶ Scaffolds associated with perimeter safety screens and shutters

### Advanced Scaffolding

Those qualified in advanced scaffolding must know how to carry out work associated with all basic and intermediate scaffolding competencies and:

- ▶ Erection of hung scaffolds
- ▶ Erection of suspended scaffolds

## The Scaffolding Basics

There are many different types of scaffolds that can be erected (depending on your licence level).

These scaffolds are made up of a number of components.

In order to correctly erect scaffolds it is important that you have an understanding of what each of these components are called (especially when interpreting a scaffolding plan).

### Parts of a Scaffold

The following diagrams outlines the parts of a scaffold:

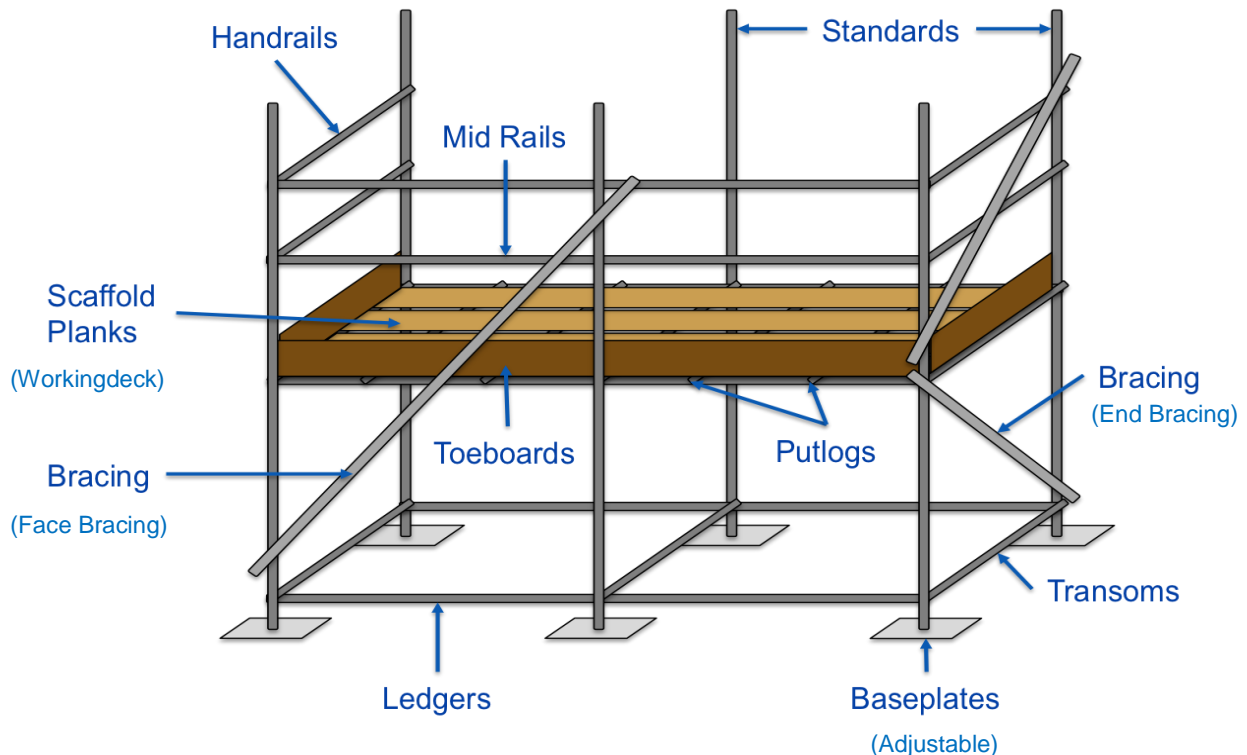

### Bays and Lifts

A **BAY** is the section of a scaffold created by four standards, ledgers and transoms placed at right angles.

A **LIFT** is the vertical distance between two ledgers or transoms

A **PANEL** is the area within two vertical standards and either two ledgers or two transoms.

The first lift is called a **BASE LIFT**.

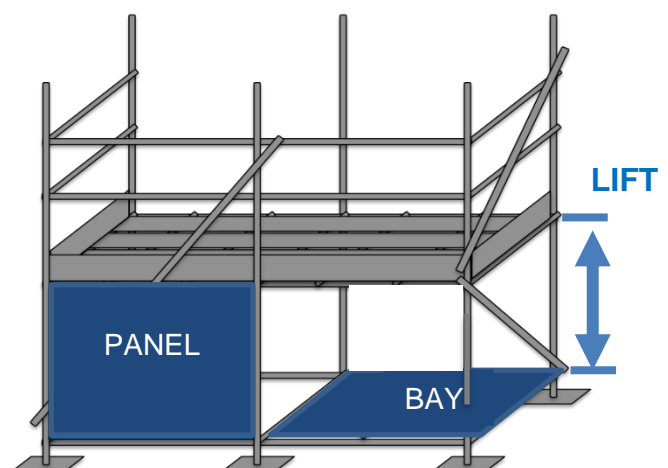





### Types of Scaffolding

When selecting a scaffold, the specified building's design, shape, and location should be considered. The scaffold's ability to adapt to the structure's contours should also be taken into account.

In addition, the purpose for which the scaffold will be used should be a factor in making the decision about which type of scaffold should be selected. You will need to decide what type of scaffold construction is the most appropriate for the tasks you need to perform.

## Basic Level Scaffolds

The following table outlines the main types of basic level scaffolds.



Name	Description	Example
Tower Scaffold	<p>A <b>Tower Scaffold</b> can be a mobile, modular, or tube and coupler variety. Tower scaffolds are generally fitted with a single work platform with ladder access and have only 2 rows of standards. Tower scaffolds are popular where there is a limited amount of space to erect a scaffold.</p>	
Modular (Steel) or Aluminium Frame Scaffolding	<p>A <b>Modular or Frame Scaffolding</b> (steel, fibreglass or aluminium) is assembled from prefabricated frames, braces and accessories. It can only be built to a height of 3x the smallest base size or 9 metres, unless otherwise specified by an engineer, or the manufacturer.</p>	
Birdcage Scaffold	<p>A <b>Birdcage Scaffold</b> consists of more than two rows of standards, connected by ledgers and transoms. It is intended for use on one level only, and is commonly used for working on a ceiling.</p>	
Bracket Scaffold	<p>A <b>Bracket Scaffold</b> is a scaffold that has a platform carried on frames attached to or supported by a permanent or temporary construction.</p> <p>Bracket scaffolds are often used for maintenance work.</p>	
Mobile Scaffold	<p>A <b>Mobile Scaffold</b> is an independent, free-standing, movable scaffold mounted on castors. It is useful for maintenance where multiple points must be accessed.</p>	







### Mobile Scaffold Specifications:

- ▶ Must have plan bracing to keep the scaffold square and rigid, as close to the ground as possible
- ▶ Must have internal access
- ▶ Maximum height 2x the smallest base width, with a maximum height of 9 metres unless otherwise specified by an engineer or the manufacturer
- ▶ Must be a minimum of 1m away from penetrations or open edges
- ▶ Must be tied as close as possible to the ground (no ties on mobiles)
- ▶ Should only be used on hard / flat level surfaces
- ▶ Wheels must have a SWL, brakes and locking devices
- ▶ Not have a pneumatic tyre
- ▶ It is illegal for persons to be on the scaffold whilst it is being moved

### Intermediate Level Scaffolds



The following table outlines the main types of Intermediate level scaffolds.

Name	Description	Example
Single Pole Scaffold	<p>A Single Pole Scaffold contains a single row of standards, and is completely dependent on the structure it is placed against for support.</p> <p>A single pole scaffold is often used for bricklaying or other masonry work.</p>	
Tube and Coupler	<p>A Tube and Coupler Scaffold is erected using scaffold tubes connected with couplers.</p> <p>These are useful where the scaffold must be erected in a specific shape to match a structure, or prefabricated scaffolds will not meet the requirements of the task.</p>	
Spurred Scaffold	<p>A Spurred Scaffold is partially supported by inclined load-bearing members called 'spurs'.</p> <p>They are used where there is insufficient load bearing capability for standards, or where the scaffold must be configured in a way that does not have all standards resting on the ground/supporting structure. An example of this is a scaffold that is built around and above an entryway.</p>	

Name	Description	Example
Sloping Scaffold / Barrow Ramp	<p>Sloping platforms: formed when scaffolding is erected at an angle on or from a conventional level scaffold. For the purposes of this unit standard sloping platforms include barrow ramps.</p> <p>Barrow ramps: a specific type of sloping platform. They are cleated and house a running board for maximum efficiency when moving up and down the slope</p>	
Cantilever Scaffold	<p>A Cantilever Scaffold is a scaffold that is supported by cantilevered load-bearing members.</p> <p>It is commonly used where surface conditions are unacceptable, or the required height of the work platform makes conventional scaffolds unsuitable.</p>	
Cantilevered Crane Loading Platform	<p>CCLP's are to be lifted by cranes and controlled by riggers, however intermediate scaffolders are to be involved in the propping, securing and bracing elements of the internal supporting structures</p>	
Gantries (covered walkways)	<p>A structure which is constructed from structural steel, scaffolding or structural timber, that is primarily intended to support a protection deck or portable building such as amenity sheds.</p>	
Perimeter Safety Screens & Shutters	<p>Perimeter safety screens and shutters are designed and installed to prevent persons from falling whilst working aloft, and also to ensure that equipment and materials can be contained and not dislodge and fall to the ground.</p>	
Mast Climber	<p>A mast climber consists of vertical structural sections (mast) that can be secured to a structure to enable a horizontal platform, that workers can be positioned in to access elevated work locations.</p> <p>The mechanical device utilized to enable the platform to climb the mast is a ratchet pinion system.</p>	

## Advanced Level Scaffolds

The following table outlines the main types of advanced level scaffolds.

Name	Description	Example
Suspended or Swing Stage Scaffold	<p>A Suspended or Swing Stage Scaffold can be either raised or lowered whilst in use, as it has a suspended platform.</p> <p>These types of scaffolds are commonly associated with window washers.</p>	
Hung Scaffolds	<p>Hung Scaffolds are temporary structures suspended by tube and fittings, wire ropes or chains from a permanent structure and are used to access areas that would otherwise be difficult or unsafe to access by other means.</p> <p>They are usually made from steel, aluminium or timber components.</p> <p>Hung scaffolds CANNOT be raised or lowered when in use. Some can, however, travel horizontally with the aid of girder trolleys or mobile suspension rigs.</p> <p>Maximum of 2.4m bay length for hung scaffold.</p>	

## Scaffold Duty

Scaffolds have different rated capacities according to their duty:

Duty	Minimum Width	Maximum Width	Maximum Length	Maximum Load Allowed on Platform when distributed
Light	450mm (2 boards)	2.4m (10 boards)	3m	225kg per bay
Medium	675mm (3 boards)	1.8m (8 boards)	2.4m	450kg per bay
Heavy	900mm (4 boards)	1.125M (5 boards)	1.8m	675kg per bay

The configuration and the parts that make it up generally determine the duty of a scaffold.

You need to make sure the scaffold you intend to erect will be the correct duty depending on the requirements of the job and the types of loads that will be resting on the scaffold while it is erected.

You should check the manufacturer's or supplier's specifications for the exact WLL of the working platforms of a scaffold at the planning stage to make sure it will be able to support the weight of any workers, tools, equipment and materials, debris and impact forces required for the job when the load is distributed.

Duty	Maximum Total Load for persons and Materials	Maximum Mass of any Single Concentrated Load of Materials or Equipment (as part of total load)
	KG per platform per bay	KG
Light *	225	100
Medium	450	150
Heavy	675	200

\* Materials must not be stored on light duty working platforms that have the minimum allowable width.

## Scope and General

The height of scaffolding as specified by the scope, has been reduced from 45m to 33m for tube and coupler steel scaffold.

The standard specifies requirements for unsheeted metal tube-and-coupler scaffolding that does not exceed 33m in height and is deemed to comply with the performance requirements of AS/NZS 1576.3 for light, medium and heavy duty loads.

For further information regarding referenced documents, refer to Referenced Documents Information section in Appendix.

## Identify Forces and Loads

A 'load' is any type of force exerted on an object. It is important to understand the relevant forces and loads that are associated with the scaffolding work you will be doing.

Forces and loads apply to scaffolds and the structures they are attached to.

When constructing a scaffold there are a range of forces and loads you may need to consider.

- ▶ **Dead Loads** – The weight of a scaffold or hoist and its components before it is loaded.
- ▶ **Live Loads** – The weight of the equipment and personnel on the scaffold (in each bay).
- ▶ **Static Load** – A load that is not moving (consistent load).
- ▶ **Dynamic Load** – Force made by a moving load on a resisting structure or component.
- ▶ **Wind Load** – The force made by wind on a structure or its components.
- ▶ **Environmental Load** – The weight of environmental factors such as water, dust and debris that may be on the scaffold.

Each standard is designed to hold at least 1/3 of the duty live load per bay. For example a medium duty scaffold that can hold 450kg per bay requires each standard to hold at least 150kg.

The maximum load that can be placed on a right-angle coupler is 630kg (AS/ NZS 1576.2 2: 2009) unless otherwise specified by the manufacturer.

It is important to know the weight of any material you place on a scaffold.

If you place too much weight on a scaffold it may collapse.

Some loads may have the weight marked on them or they may come with a consignment note or weighbridge certificate.

You may have to calculate the weight of a load using appropriate mathematical procedures and formulas. Remember to add the weight of pallets, boxes and drums when lifting loads.

Material	Weight
Cubic metre of concrete	2.4 metric tonnes
Cubic metre of water	1 metric tonne
Cubic metre of earth or clay	1.9 metric tonnes
Cubic metre of mild steel	7.84 metric tonnes
1000 common bricks	4 metric tonnes

## Occupational / Work Health & Safety

### OHS/WHS Requirements

Occupational Health & Safety/Work Health & Safety (OHS/WHS) is defined as laws and guidelines to help keep your workplace safe.



These can be broken down into four main types:

Law	Explanation
Acts	Laws to protect the health, safety and welfare of people at work.
Regulations	Gives more details or information on Specific parts of the Act.
Codes of Practice	Are practical instructions on how to meet the terms of the Law.
Australian Standards	Give you the minimum levels of performance or quality for a hazard, work process or product such as AS/NZS 1576. Note: other valid Australian Standards may also apply.

### Harmonisation of Work Health & Safety Legislation

In response to industry calls for greater national consistency, the Commonwealth, states and territories have agreed to implement nationally harmonised Occupational/Work Health & Safety (OHS/WHS) legislation.

While not all states and territories have actually implemented the model OHS/WHS legislation as of the start of 2012, it is important to be aware of these changes, as all states and territories will eventually implement them.

At all times during scaffolding operations, Commonwealth, State or Territory Legislation must be adhered to.

Harmonisation aims to develop consistent, reasonable and effective safety standards and protections for all Australian workers through uniform OHS/WHS laws, regulations and codes of practice.

The following OHS/ WHS legislative requirements will affect the way that you work:

- ▶ Duty of Care
- ▶ Australian Standards (AS/ NZS 1576)
- ▶ Industry OHS/ WHS Standards and Guidelines
- ▶ Health & Safety Representatives, Committees and Supervisors
- ▶ Job Safety Analysis/Job Hazard Analysis (JSA/JHA) and Safe Work Method Statements (SWMS)
- ▶ Licences, Tickets or Certificates of Competency
- ▶ National safety standards
- ▶ OHS/WHS and Welfare Acts and regulations
- ▶ Safety Codes of Practice



Talk to your OHS/WHS officer or representative if you have any questions about OHS/WHS legislation.

## Consultation and Communicating with Others

Communication and consulting with others is an important part of the risk management process and should take place at all stages.

Identifying risks and hazards and coming up with ways of controlling them includes talking to the people with knowledge of the situation, or who are directly affected by any action you may take.

Controlling a hazard can be a team effort and it's important that everybody knows what they need to do and how/if they need to change their work process to suit.

Make sure you talk to the following people about hazards before you start work:

- ▶ Safety officers.
- ▶ Site engineers (where applicable).
- ▶ Supervisors.
- ▶ Colleagues.
- ▶ Managers who are authorised to take responsibility for the workplace or operations.
- ▶ Health and safety representatives.

It is important to communicate with workplace personnel and safety officers before starting on a worksite to ensure that the scaffold team is aware of any workplace policies, site-specific procedures and hazards.

## Identify and Control Hazards



**Hazards create risk. Check for hazards.**

A **RISK** is the chance of a hazard hurting you or somebody else or causing some damage.

A **HAZARD** is the thing or situation that causes injury, harm or damage.

If you can remove or at least control a **HAZARD** you can reduce the **RISK** involved.

Before conducting a risk assessment at a worksite, check to see what systems and procedures are in place as they may affect the outcomes of the risk assessment.

It is important that suitably knowledgeable personnel/workers are involved in the risk identification process.

Common workplace hazards include:

- ▶ Ground conditions:
  - ◊ Non-weight bearing surfaces
  - ◊ Underground services
- ▶ Poor lighting.
- ▶ Overhead hazards:
  - ◊ Power lines
  - ◊ Overhead service lines
  - ◊ Obstructions
  - ◊ Falling objects
- ▶ Surrounding structures:
  - ◊ Buildings
  - ◊ Obstructions
  - ◊ Facilities
  - ◊ Trees
  - ◊ Equipment
- ▶ Traffic:
  - ◊ Pedestrians
  - ◊ Personnel
  - ◊ Vehicles
  - ◊ Mobile plant
- ▶ Weather:
  - ◊ Wind
  - ◊ Lightning
  - ◊ Rain
- ▶ Workplace-specific hazards:
  - ◊ Dangerous materials
  - ◊ Falling from heights



Part of your job is to look around to see if you can find any hazards before you start.

When identifying hazards always remember to look:

- ▶ **Above head height** – remember that scaffolding may be above your head.
- ▶ **At eye level** – look around to see if there is anything in the way of where you want to place the scaffold.
- ▶ **On the ground (and below)** – Have a look at the ground conditions - will it support the weight of the scaffold and load?

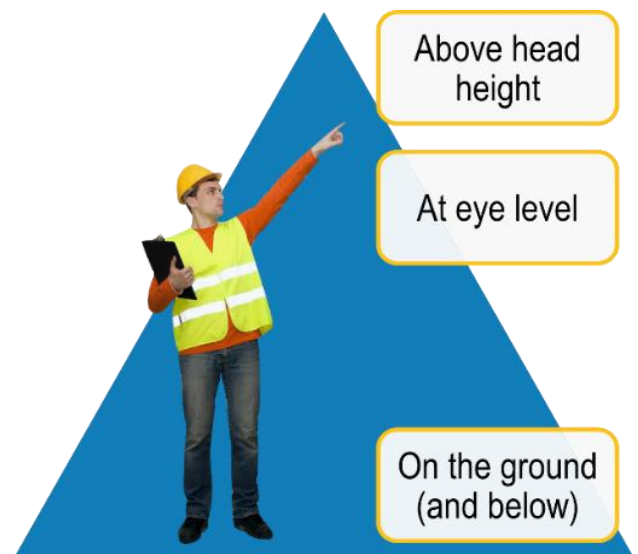

Make a note of any hazard you identify in the area. Remember, a hazard can also be a situation so keep an eye on how the people around you are working too.

Each task/ procedure/ function needs to be evaluated for risks, as well as the work area where the work is being carried out.

You should also check records of injuries and incidents, safety tags and talk to other workers.

Material Safety Data Sheets (MSDS), now known as a Safety Data Sheet (SDS) can be a useful tools in identifying potential hazards so make sure you check the MSDS/ SDS documents for your site.

Talk to other workers, your manager, supervisor, team leader or health & safety representative to find out if the risk has already been addressed, and what techniques are available to you to resolve it.

If you find that there is no documentation or guideline in place to resolve an identified risk, you need to assess the risk and identify a feasible course of action to deal with it.

It is important that all records, policies and procedures are kept up to date so that the most relevant information is available and used.

## Working Near Power Lines

Working near power lines can be extremely dangerous.

It is very important that you know the safe operating distances for different types of power lines and the steps you must take if your job needs you to work closer than the safe distances.

Generally, if you need to work closer than the safe work distance you must:

- ▶ Contact the local electrical authority for permission to work closer (this is called an exemption).
- ▶ Have the power lines shut off. If this is not possible then have the power lines insulated.
- ▶ Use a spotter (depending on local laws and rules).



Distances are different depending on the state or territory you are working in and the voltage of the power lines. You should check with the local electrical authority for information and advice to find out the voltage of power lines in your work area.

## State Distance Information

### Western Australia

In Western Australia, this falls under **Regulation 3.64 from the OSH Regulations** and states the following as the minimum distances:

Power Line Type	Distance
Up to 1kV or 1000v (insulated)	0.5m
Up to 1kV or 1000v (uninsulated)	1.0m
Above 1kV or 1000v and up to 33kV or 33,000v	3.0m
Above 33kV or 33,000v	6.0m

**\*NOTE: Regulation 5.28 of the Mines Safety Inspection Act requires at 10m powerline corridor. Insulation sleeves must extend a minimum of 5m past each end of the scaffold.**

## Queensland

The Queensland Electrical Safety Regulation breaks down the distances in detail. Exclusion zones are broken down not only by size of power line but also by the competency level of the operator. This means that the requirements should be clarified with the electrical authority before work commences even if the distance appears to be outside the zones.

The following minimum distances are provided as guidance:

Power Line Type	Distance
Up to 132kV	3.0m
132kV up to 330kV	6.0m
330kV and above	8.0m

## Northern Territory

In the Northern Territory equipment must not be closer than the following distances to power lines:

Power Line Type	Distance
Up to and including 132kV (distribution lines)	6.4m (or 3m with a spotter)
Greater than 132kV (transmission lines)	10m (or 8m with a spotter)

## Australian Capital Territory

In the ACT, mobile plant operators and persons erecting or working from scaffolding must maintain a safe minimum distance to power lines as outlined in the table below:

Power Line Type	Distance
Less than 33kv	4.0m
33kV or more (transmission lines)	5.0m

## Victoria

In Victoria, the Framework for Undertaking Work Near Overhead and Underground Assets states that equipment must not be closer than the following distances to power lines:

Power Line Type	Distance
Distribution lines up to and including 66kV (power poles)	6.4m (or 3.0m with a qualified spotter)
Transmission lines greater than 66kV (towers)	10m (or 8m with a qualified spotter)

## Tasmania

In Tasmania equipment must not be closer than the following distances to power lines:

Power Line Type	Distance
Up to and including 133kV (poles)	6.4m (or 3m with a safety observer)
Greater than 133kV (towers)	10m (or 8m with a safety observer)

## South Australia

In South Australia, mobile plant operators and persons erecting or working from scaffolding must maintain a safe minimum distance to power lines as outlined in the table below:

Power Line Type	Distance
Up to 132kv (including 132kv poles)	6.4m (or 3.0m with a spotter)
132kv or more (including 132kv towers)	10.0m (or 8.0m with a spotter)

## New South Wales

In New South Wales, for anyone who is not accredited, equipment operation may not be any closer than the following distances to power lines:

Power Line Type	Distance
Up to and including 132kV	3.0m
Above 132kV up to and including 330kV	6.0m
Above 330kV	8.0m

To work closer than these distances requires authority from the relevant electrical authority and adherence to cl.64(2)(e) of the regulations.



### Tiger Tails

Tiger tails are used to visually and clearly indicate the location of overhead power lines. Tiger tails **DO NOT** insulate the power lines, so exclusion zones and safe operating distances must still be used, even when tiger tails are in use.

## Task-Related Hazards

There may be other factors that you need to consider when planning out the task, **other than site hazards**, relating to the way the task is carried out.

When planning out the task, some things you may consider are:

- ▶ Location of task
- ▶ Task plans & Schedules
- ▶ Height & length and width of the scaffold
- ▶ Load the scaffold needs to support
- ▶ Weights or relevant information to carry out the task
- ▶ Access and egress
- ▶ Plant & equipment required
- ▶ Availability of plant & equipment
- ▶ Site rules and procedures
- ▶ Permits required
- ▶ SWMS and JHA's
- ▶ Induction/training

## Risk Assessment

A Risk Assessment must be conducted prior to commencing all scaffolding operations.

It involves completing a Risk Analysis and a Risk Evaluation.

By assessing the likelihood and consequence of the risk you are able to understand the situation better and respond in an appropriate way.

### Risk Analysis

Once you have identified the hazards on site or related to the work you will be doing you need to assess their risk level.

Risk analysis involves considering what are the causes and sources of risks and comprises 3 factors:

<b>Consequence</b>	What would be the outcome of the event occurring? How severe would the outcome be?
<b>Likelihood</b>	What is the chance of the event/consequence occurring? Has the event happened before? Is it likely to happen again?
<b>Risk Level</b>	The combined result of likelihood and consequence.

Using a table similar to the one shown here you can analyse how high the risk level is:

<b>SEVERITY (HARM POTENTIAL)</b>	<b>MAJOR</b>	5	<b>5</b>	<b>10</b>	<b>15</b>	<b>20</b>	<b>25</b>
	<b>HIGH</b>	4	<b>4</b>	<b>8</b>	<b>12</b>	<b>16</b>	<b>20</b>
	<b>MEDIUM</b>	3	<b>3</b>	<b>6</b>	<b>9</b>	<b>12</b>	<b>15</b>
	<b>LOW</b>	2	<b>2</b>	<b>4</b>	<b>6</b>	<b>8</b>	<b>10</b>
	<b>NEGLIGIBLE</b>	1	<b>1</b>	<b>2</b>	<b>3</b>	<b>4</b>	<b>5</b>
	<b>Score</b>		<b>1</b>	<b>2</b>	<b>3</b>	<b>4</b>	<b>5</b>
			<b>RARE</b>	<b>UNLIKELY</b>	<b>PROBABLE</b>	<b>MORE LIKELY</b>	<b>ALMOST CERTAIN</b>
			<b>LIKELIHOOD</b>				

## Risk Evaluation

Risk evaluation is based upon the outcomes and results of the risk analysis.

Risk evaluation involves making decisions about which risks need to be treated and the order in which they should be treated. It should take into consideration the context of the risks in relation to:

- ▶ The organisation.
- ▶ The worksite.
- ▶ The relevant laws.
- ▶ Regulations.
- ▶ Other policies, procedures and requirements.

Using a table similar to the one shown you can evaluate how soon you should act to remove or control the hazard to achieve an acceptable level of risk:

RISK LEVEL	ACTION
VERY HIGH	<p><b>This is an unacceptable risk level</b></p> <p>The task, process or activity <b>must not proceed</b>.</p>
HIGH	<p><b>This is an unacceptable risk level</b></p> <p>The proposed activity can only proceed, provided that:</p> <ol style="list-style-type: none"> <li>1. The risk level has been reduced to as low as reasonably practicable using the hierarchy of risk controls.</li> <li>2. The risk controls must include those identified in legislation, Australian Standards, Codes of Practice etc.</li> <li>3. The risk assessment has been reviewed and approved by the Supervisor.</li> <li>4. A Safe Working Procedure or Work Method Statement has been prepared.</li> </ol> <p>The supervisor must review and document the effectiveness of the implemented risk controls.</p>
MEDIUM	<p><b>This is an acceptable risk level</b></p> <p>The proposed activity can only proceed, provided that:</p> <ol style="list-style-type: none"> <li>1. The risk level has been reduced to as low as reasonably practicable using the hierarchy of risk controls.</li> <li>2. The risk assessment has been reviewed and approved by the Supervisor.</li> <li>3. A Safe Working Procedure or Work Method Statement has been prepared.</li> </ol>
LOW	<p>The proposed task or process needs to be managed by documented routine procedures, which must include application of the hierarchy of controls.</p>

Any task with a risk level that is Very High is absolutely unacceptable to carry out. Steps must be taken to reduce the risk level.

The action you take will depend on:

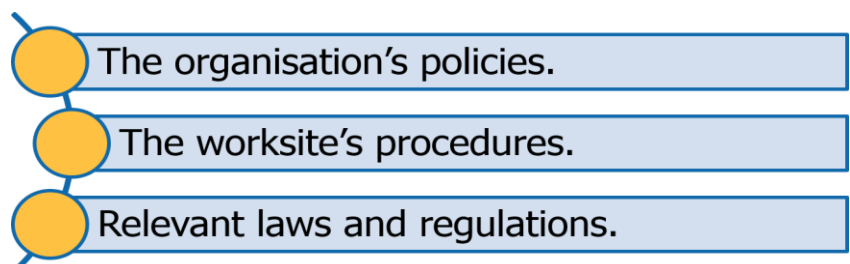

## Risk & Hazard Controls

Once hazards and risks have been identified and assessed you need to work out what the best way to manage them will be.

The Hierarchy of Hazard Control is the name given to a range of control strategies used to eliminate or control hazards and risks in the workplace.

You may need to use a range of control measures to reduce the risk to an acceptable level.

Hazard controls need to be implemented before you start work or as soon as a hazard is identified during the work.

### Hierarchy of Controls

The Hierarchy has 6 levels.

Always start at the top of the list and work your way down.

Hierarchy Level	Explanation
<b>1. Elimination</b>	Completely remove the hazard. This is the best kind of hazard control.
<b>2. Substitution</b>	Swap a dangerous work method or situation for one that is less dangerous.
<b>3. Isolation</b>	Isolate or restrict access to the hazard.
<b>4. Engineering Controls</b>	Use equipment to lower the risk level.
<b>5. Administrative Controls</b>	Site rules and policies attempt to control a hazard. Includes Safe Work Practices.
<b>6. Personal Protective Equipment (PPE)</b>	The least effective control. Use PPE while you work. This should be selected at the planning stage of your work, and checked before starting the job.

It is important to consider all of the options available when deciding on the best course of action.

Not all options are feasible or possible under some circumstances.

Your plan should clearly identify the order in which to implement the individual risk treatments.

## Prepare A Scaffolding Plan

When you are planning out the scaffolding task and the use of scaffolding equipment it is very important to consult with other people involved in the job. You may need to talk to supervisors, colleagues, managers responsible for workplace/operations, and other scaffolders/site workers.

The procedures and techniques you plan to use to complete your tasks should conform with all legal requirements related to scaffolding work including:

- ▶ Relevant commonwealth, state or territory Occupational Health & Safety/Work Health & Safety (OHS/ WHS) legislation.
- ▶ Local government regulations.
- ▶ Scaffolding standards and codes of practice.
- ▶ Australian Standard AS/ NZS 1576.
- ▶ Guidelines for scaffolding AS/NZS4576.

This Australian Standard outlines the performance requirements and methods of structural and general design for access and working scaffolds. In general these requirements also apply to other types of working scaffolds.

The purpose of a working scaffold is to provide a safe place of work with safe access suitable for the work being done. The Australian Standard sets out the structural and operational requirements for working scaffolds.

Your plan should include information on how you intend to carry out the task (sequence), how you intend to deal with any unidentified hazards and what components you will use to complete the scaffold.

The details of the scaffold plan may include:

- ▶ The number of bays, lifts and platforms
- ▶ The location of the scaffold
- ▶ The location of ties and bracing
- ▶ Details of scaffold access
- ▶ The duty of the scaffold (light medium or heavy)

Your plan should refer to the scaffold plans/drawings and any other relevant documentation such as work method statements or site procedures.

These drawings can be used as a reference to determine the scaffold elements/parts that are required to erect it and the configuration of work platforms, ladder access and other components or associated equipment.

Make sure everybody involved in the scaffolding work is familiar with the plan and understands what they need to do.

## Identify, Select and Inspect Equipment

A scaffolding task may require the use of a wide range of scaffolding, associated and safety equipment to be used and installed.

Part of completing the planning for the scaffolding job is to identify what equipment you will need, then select and inspect that equipment to make sure it is safe for use.

It is very important that you check all equipment before you use it to ensure that it is safe to use and suitable for the task.

You may need to consult with other people involved in the job such as supervisors, colleagues, managers, other scaffolders, and site personnel when identifying the equipment needed to carry out the scaffolding task.

The erection, alteration and dismantling of scaffolds requires you to use a range of associated equipment.

Associated equipment includes:

- ▶ Pre-fabricated/modular components
- ▶ Scaffold tubes/tube fittings/couplers and boards
- ▶ Adjustable props and screening
- ▶ Prefabricated needles & Counterweights
- ▶ Ladders and stairways
- ▶ Cantilevered crane loading platforms (CCLP's)
- ▶ Mast climbers and material hoists
- ▶ Perimeter safety screens and shutters
- ▶ Fibre Ropes (for handlines or gin wheels) and Flexible Steel Wire Rope (FSWR) (for guy wires)
- ▶ Gin wheels
- ▶ Hand tools
- ▶ Cradles, hoists, hoist ropes

Check the drawing/design or the manufacturer's manual to make sure you have all of the parts you need. To ensure the correct quantities and types of equipment required are correct, measure and calculate all components.

## Scaffold Basic Level Equipment

### Footings

There are 2 main types of footing for a scaffold:

- ▶ Base plates.
- ▶ Adjustable base plates (screw jacks).

Footings are used to provide a stable foundation for the scaffold and to prevent unwanted movement. Depending on the ground conditions, soleplate or sole boards may be used under the base plates to provide a more stable surface. Make sure the soleplates are strong and rigid enough to distribute the load.

The minimum size of a square baseplate is (150mm x 150mm) and it should be at least 6mm thick.

The maximum extension on an adjustable baseplate is 600mm.

**The shank (unthreaded part) of an adjustable base plate should extend at least 150mm, or ¼ of the total length of the tread (whichever is greater) past the maximum extension.** This is to ensure that there is enough of the shank sitting within the standard to keep the scaffold stable.

The maximum load to be placed on an adjustable base plate depends on the design of the scaffold.

Check all footings for damage or wear before use. Check that adjustable base plates wind and unwind smoothly and they are not bent or warped. Do not use any equipment that is faulty or damaged.

### Scaffold Tubes

Scaffold tubes shall comply with AS/NZS 1576.3

Scaffold tubes may be made from aluminium or steel.

The minimum outside diameter of a common scaffold tube is 48.3mm.

The minimum wall thickness of a common steel scaffold tube is 4mm.

The common steel scaffold tube weights 4.5kg per metre.

The minimum wall thickness of a common aluminium scaffold tube is 4.47mm.

The minimum outside diameter of a common aluminium scaffold tube is 48.4mm.

### Mixing of Tubes

Aluminium and steel tubes shall not be mixed in the one scaffold except for guardrails, midrails or other members that are not structural members.

### Scaffold Tubing Sizes

Scaffold tubing sizes available in lengths are: (meters)

0.3    0.6    0.9    1.2    1.5    1.8    2.1    2.4    2.7    3.0    3.3    3.6    3.9    4.2  
 4.5    4.8    5.1    5.4    5.7    6.0    6.3

Possible scaffold tube defects:		
Pitted	Flame cut	Cross cut
Split ends	Mushroom headed	Bent
Tube wall thickness less than minimum requirements		

If any of these are present then the scaffold tube **MUST NOT BE USED!**

## Scaffold Planks

Shall comply with AS/NZ 1577

Planks are used to construct working platforms.

They can be made of timber, aluminium or steel.

Planks should have the correct information displayed upon them.

The minimum width of a scaffold plank is 225 mm. The minimum thickness of a hardwood solid timber scaffold plank is 32 mm.

The weight of a hardwood scaffold board is 7kg per metre.



### Scaffold Plank Sizes

Scaffold plank sizes available in lengths are: (meters)

0.3 0.6 0.9 1.2 1.5 1.8 2.1 2.4 2.7 3.0 3.3 3.6 4.2

Do not use scaffold planks with any of the following faults:

Possible timber plank defects:		
Warped	Split	Broken
Twisted	Knots	Moisture / Chemical
Possible metal plank defects:		
Twisted	End cap missing	Crushed
Distorted	Broken weld reinforcing strap	Rust / Corrosion

If any of these are present then the plank **MUST NOT BE USED!**

It must be tagged out of service, quarantined and reported to your supervisor.

## Ladders

Ladders are used to access a scaffold.

All ladders used shall be a single length, industrial grade and must comply with AS/ NZS 1892 and have a SWL of a minimum of 120kg.

It is not acceptable to use a personnel hoist as the only way to access a scaffold's working platform. If there is an emergency or mechanical breakdown, all workers on the scaffold need an alternate and safe means of exiting the scaffold.

**DO NOT** use a domestic grade ladder.

It is vital that you only use ladders that are in good working order.

Possible ladder defects:	
Timber stiles are warped, splintered, cracked or bruised	Metal stiles are twisted, bent or kinked
Crushed damaged welds or damaged feet	Ropes, braces or brackets are missing, worn or broken
Rungs are missing, worn, damaged or loose	Missing or unreadable / illegible tag
Ladder is painted	Ladder is not industrial strength

If any of these are present then the ladder **MUST NOT BE USED!**

## Tie Tubes

Tie tubes are used to fix a scaffold to the structure to provide support and stability. A structural engineer should be consulted regarding the structure the scaffold is being tied into, to ensure its integrity and strength. This keeps the scaffold erect, level and stable. Generally, they are connected to the scaffold using a right-angle coupler. They must be connected to a minimum of 2 standards of the scaffold. *For further information see 'Bracing and Ties' section from pg 89.*

Check that they are not damaged or worn and that the scaffold tubes connect properly.

Check that all components are not damaged or worn. Check that all components fit together securely.

The supplier of prefabricated scaffolding needs to provide written information about the systems.

Do not mix different components from different prefabricated scaffold systems without consent from the supplier or a qualified engineer.

## Gin Wheels

Gin wheels are used to raise and lower loads. They may be a 'hook type' or a 'ring type' depending on the way it is attached to a scaffold tube.

- ▶ There must be a data plate on the gin wheel's head stock stating its SWL and serial number.
- ▶ The minimum diameter of non-conductive fibre ropes you would use for a gin wheel 16mm.
- ▶ The maximum load you would lift with a gin wheel 50kg.
- ▶ Do not use gin wheels that are not fitted with rope guides.

## Static Safety Lines

Static lines are horizontal or substantially horizontal lines to which a lanyard may be attached and which is designed to arrest a free fall.

These provide a suitable anchor point for a fall-arrest system, while still allowing a limited range of movement along the path of the line.

The parts of a static line need to be checked periodically while the system is in use.

You should be checking for faults such as:

Component	Condition/fault to be checked
<b>FSWR</b>	<ul style="list-style-type: none"> <li>▶ Kinks or fractures from bending or reeving.</li> <li>▶ Crushed or damaged strands.</li> <li>▶ Damaged splice.</li> <li>▶ Exposure to high temperatures.</li> <li>▶ Wear and abrasion.</li> <li>▶ Broken wires.</li> <li>▶ Damage to the ferrule.</li> <li>▶ Damage to the eye.</li> <li>▶ Damage to the thimble.</li> <li>▶ Core collapse.</li> <li>▶ Bird-caging where strands loosen from their proper tight lay.</li> <li>▶ High stranding.</li> <li>▶ Corrosion indicated by loose springy wires.</li> <li>▶ Knotting.</li> <li>▶ More than 10% wear in the diameter of the rope.</li> <li>▶ Broken wires exceeding the allowable limit.</li> </ul>

<b>Anchors and Connectors</b>	<ul style="list-style-type: none"> <li>▶ Damage.</li> <li>▶ Wear.</li> <li>▶ Irregular or excessive movement.</li> <li>▶ Security of parts.</li> <li>▶ Capacity markings or information are present.</li> <li>▶ Any indication that the component may fail during use.</li> </ul>
-------------------------------	---

If any of these are present then the static safety lines **MUST NOT BE USED!**

### Safety Nets

Industrial safety nets are sometimes used as an effective means of fall protection for those working at heights where it is not practicable to provide scaffolds or temporary guard railings.

When combined with overlay nets of finer mesh size, they can also be used to contain falling debris.

Safety nets may be installed where there is a risk of tools, equipment and materials falling from a height on other workers, plant, machinery, structures or pedestrians.

Before installing a safety net you need to make sure it is in safe working condition.

Common faults to check for are:

- ▶ Missing or illegible tag
- ▶ Damage.
- ▶ Stretching.
- ▶ Frayed fibres.

You also need to check the safety net to make sure that it has been used, handled and stored correctly.

<b>Before using a net look for any signs that may indicate the following:</b>
Dragging the net over rough surfaces or edges.
Contact of chords with sharp edges.
Stacking of materials on net.
Accumulation of debris in the net.
Indications of people jumping or throwing things into the net.
Indications of contact with flames or sparks from welding or oxy cutting equipment.
Contact with hot gasses from blowtorches.
Contact with ashes from chimneys or furnaces.
Chemical attack.
Damage to the supporting framework from collisions or being struck by moving loads.

If any of these are present then the safety nets **MUST NOT BE USED!**

**If anything looks unsafe or out of order you must not use it, tag it out of service and quarantine the component, log the issue and report it to your Supervisor immediately.**

## Scaffold Intermediate Level Equipment

### Couplers and Fittings

Couplers and accessories shall comply with AS/NZS 1576.2

Couplers may be used in conjunction with the modular components of a prefabricated scaffold in a number of ways including:

- ▶ Connecting ties to the scaffold.
- ▶ Attaching bracing to the scaffold.
- ▶ Keeping scaffold equipment in place (for example gin wheels).
- ▶ Preventing scaffold components from dislodging or coming apart.



A right angle (90°) coupler is rated to a maximum loading of 630kg.

## Associated Equipment

### Scaffold Basic Level Equipment

#### Screening



Sheeting or screening is used to protect workers from environmental hazards such as dust and sunlight.

Do not use flammable material such as hessian for sheeting.

An engineer should always check the design of a sheeted scaffold, this is due to wind and environmental loads which could affect the scaffold's stability, and advise of further tying in of the scaffold.

#### Adjustable Props

**All adjustable props must be marked with an SWL.**

**Basic scaffolding** work involving formwork or reinforcing structures, prior to erecting modular scaffolding or material hoists on a concrete slab.

Adjustable props are also used to support temporary beams (needles) for cantilevered scaffolds and similar equipment, such as cantilevered crane loading platforms (CCLP), **intermediate scaffolding**.

They can also be used to secure suspension rigs/ prefabricated needles that are located within a structure (floor above and below), **advanced scaffolding**.

Generally, adjustable props come with two mechanisms for adjustment:

- ▶ A pin (sometimes called a prop or "G" pin) is used for coarse adjustments.
- ▶ A threaded collar is used for fine adjustments.

Make sure that all parts move and lock properly and that the prop is rated for the job. If you are unsure check with the manufacturer.



#### Scaffold Belts and Hand Tools

There are many different tools and maintenance equipment you can use for the various tasks needed to construct a scaffold including:

- |                             |                       |
|-----------------------------|-----------------------|
| ▶ Scaffold keys or ratchets | ▶ Podgers & wrenches  |
| ▶ Open end or ring spanners | ▶ Cutters & wire nips |
| ▶ Spirit and torpedo levels | ▶ Hammers             |
| ▶ Tape measures             |                       |

A scaffold belt can be used to carry hand tools while working.

All tools and equipment used for the erection, alteration and dismantling of scaffolds must be used in accordance with the manufacturers specifications, organisational policies and procedures and safe work practices.

Read the operators manual before using any equipment for the first time.

Do not exceed the limitations of the equipment – it could be extremely dangerous and could damage the equipment.

Always check that all tools and equipment are functioning correctly and that they do not show any signs of damage or wear. This may also require attaching tool lanyards to restrain tools from being dropped.



## Materials Hoists

Materials hoists are used to lift and lower materials between the ground and a working platform. Materials hoists run up and down the outside of a tower using a rack and pinion or wire rope hoisting system for raising and lowering the platform.

They are designed to transport materials only, and personnel/ workers must never ride on the hoist unless is otherwise specified by the manufacture. This can include the installation, adjusting, inspection and dismantling of the equipment.

This would then require the scaffolder to wear a full body harness in conjunction with an adjustable lanyard and hook up to the designed and approved anchor point, which is located inside the platform and which is clearly marked.

For inspection, check that all parts are present. Check for any signs of damage or wear.

Always refer to the manufacturer's instructions when inspecting the materials hoist components.



## Scaffold Intermediate Level Equipment

### Mast-climbing Work Platforms

Mast-climbing work platforms are available for use as either freestanding units or in single or multiple tower configurations progressively ties to the supporting structure as they are erected.

Mast-climbing systems in Australia must have their design registered with a regulatory authority.

The supplier's information for a particular model of mast-climbing work platforms should:

- ▶ Confirm that its design has been registered according to regulatory requirements
- ▶ Provide sufficient information that will enable the scaffolder or rigger to erect, alter and dismantle the unit safely within design limitations
- ▶ Include testing requirements, pre-operation checks and servicing requirements



## Cantilevered Crane Loading Platforms

Cantilevered Crane Loading Platforms (CCLPs) are used to place loads with a crane into work areas high up off the ground.

These platforms may only be installed by a person with the following licences:

- ▶ A Basic Rigging High Risk Work Licence.
- ▶ An Intermediate Scaffolding High Risk Work Licence.



## Prefabricated Needles & Counterweights

Prefabricated needles are used to support a cantilevered scaffold. These are purpose built and designed to support a specific amount of weight.

Some needles may be mounted to a rail allowing lateral (sideways/horizontal) movement.

These needles are often used in conjunction with purpose designed counterweights.

Counterweights may be used to help support a cantilevered scaffold that is attached to prefabricated needles.

It is important that these counterweights are secured to prevent any accidental removal while the scaffold is in use.

## Flexible Steel Wire Rope (FSWR)

### Guy Wires and Static Lines

Flexible steel wire ropes (FSWR) can be used for the termination of static lines and as guys for scaffolds.

To determine the rated capacity of FSWR , **for this purpose only** use the formula:

$$\text{Rated Capacity} = D^2 \text{ (mm)} \times 8$$

OR

$$\text{Rated Capacity} = \text{Diameter (mm)} \times \text{Diameter (mm)} \times 8$$

You must check any FSWR carefully before using it. The checklist below outlines what you are looking for. If a FSWR shows any of these then it is unsuitable for use.

Possible FSWR defects:	
Missing or illegible rated capacity markings	Excessive number of broken wires
Bird-caging (Strands loosened from proper tight lay)	Severe kinking or fractures from bending or reeving
More than 10% wear in the rope diameter	Crushed/ damaged strands
Splice, ferrule, eye or thimble damage	Abrasion wear
Squashed	Stretched or overloaded
Knotted	Core collapse
Severe/ serious corrosion (indicated by loose and springy wires)	High stranding
Chemical exposure	High temperature exposure

If any of these are present then the rope **MUST NOT BE USED!**

## Hung Scaffolding

Flexible Steel Wire Rope (FSWR) has been in use in the Construction and Mining Industries for many years.

Its main use is in lifting applications from cranes to drag lines, however can also be utilised to install both hung and suspended scaffolding.

- ▶ FSWR comes in a great range of sizes and configurations.
- ▶ All FSWR Slings must be stamped with the WLL stamped on the ferrule or have a WLL tag.
- ▶ The minimum diameter for a hung scaffold is 11mm (AS/NZS4576:1995)
- ▶ The minimum FSWR construction used by industry is 6 strands x 24 wires construction for a hung scaffold.
- ▶ FSWR must not be exposed to temperatures over 95°C

## Rope Lay Types

Lay is the direction the wires are formed into strands and the strands are formed into the finished rope.

The strands can be laid either left or right around the core. In left hand lay the strands are laid anti-clockwise and in right hand lay they are laid clockwise.

Ordinary lay is where the wires are laid in the opposite direction to the strands.

Lang's lay is where the wires are laid in the same direction as the strands.

**Ordinary lay (not Lang's Lay) is the main and best rope construction to use for hung scaffolding purposes.**

FSWR can be laid in:

- ▶ Right Hand Ordinary Lay - RHOL
- ▶ Left Hand Ordinary Lay - LHOL

## FSWR Characteristics

- ▶ The Tensile strength of the wire rope is not affected by the lay of the rope.
- ▶ As a wire sling is subjected to tension the rope tends to twist – not an issue with lifting slings as they are relatively short.

As a rule, these types of ropes are used in the following applications.

- ▶ **Ordinary lay fibre core** is used mainly for slings for a hung scaffold when crushing is not a factor (i.e. single layer hoist drum).
- ▶ **Fibre core** is more flexible but is prone to crushing and deformation.

## FSWR Construction

FSWR is constructed of wires and strands laid around a central core which make up the rope.

It is important not to confuse wires and strands. If a strand is broken, the rope is unusable. A single broken wire in a sling is not as important unless broken immediately below a metal fitting or anchorage.

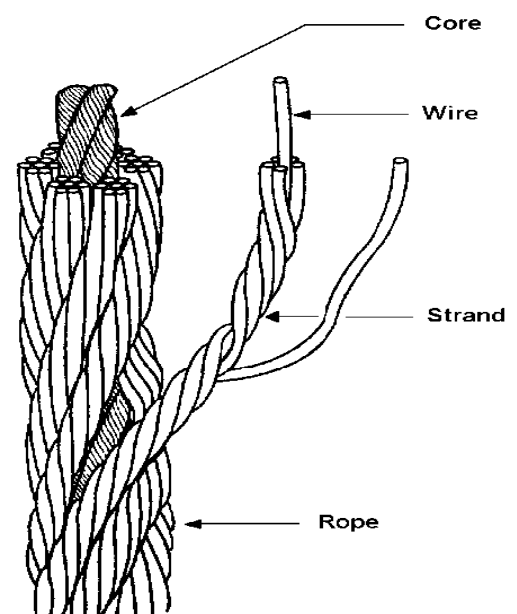

FSWR is made up of three major components:

- ▶ Wires.
- ▶ Strands.
- ▶ Core.

FSWR is described by its size, construction and its lay, i.e.

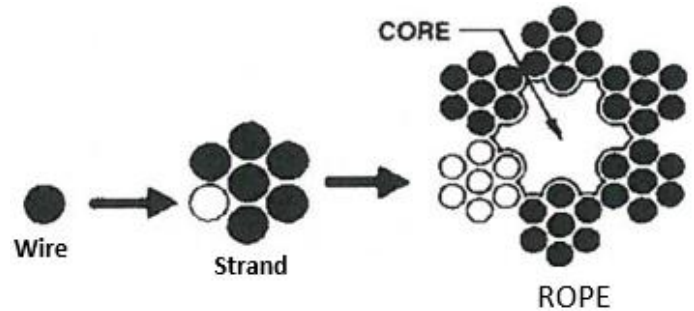

Ropes are referred to by diameter size. The correct way to measure FSWR is shown below.

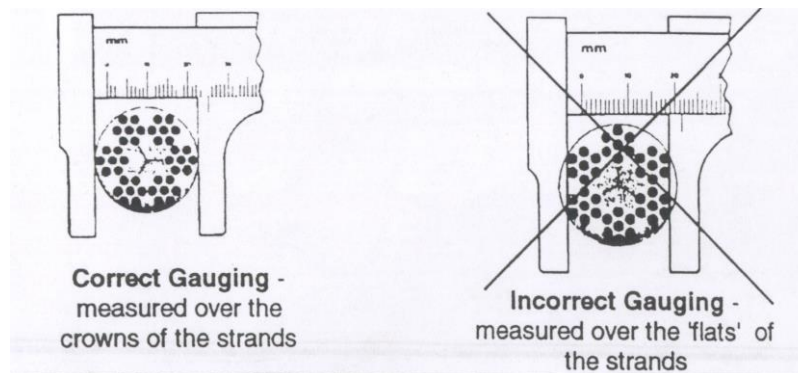

### Core Types

The core can be:

- ▶ Fibre Core (FC)
- ▶ Independent Wire Rope Core (IWRC)
- ▶ Plastic Core (PC)

### Types of FSWR

The tensile strength of wire ranges from 1220 megapascals (MPa) to 2250 MPa. The most commonly used tensile strengths are 1770 MPa and 1570 MPa.

A 6/24 (six strands of 24 wires each) is the minimum FSWR construction that can be used for slings for a hung scaffold.

The size of a rope is determined by its diameter. The smallest diameter FSWR that can be used for a hung scaffold is 11mm.

### FSWR Inspection

FSWR slings must be inspected before and after use, to ensure it is suitable for its purpose.

Check for -

- |  |                     |
|--|---------------------|
| ▶ Missing or illegible SWL/WLL tag or stamp marking                | ▶ Abrasion wear     |
| ▶ Kinks or fractures from bending or reeving                       | ▶ Damage to ferrule |
| ▶ Crushed or damaged strands                                       | ▶ Damage to eye     |
| ▶ Damaged splice   | ▶ Damage to thimble |
| ▶ Exposure to high temperatures                                    | ▶ Core collapse     |
| ▶ Stretched or overloading   | ▶ High stranding    |
| ▶ Corrosion  | ▶ Broken wires      |
| ▶ Bird-caging where the strands loosen from their proper tight lay |                     |



**Kinks**

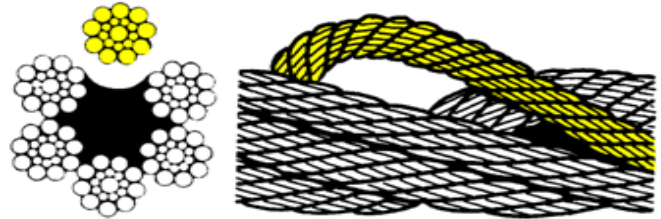

**Birdcaging**

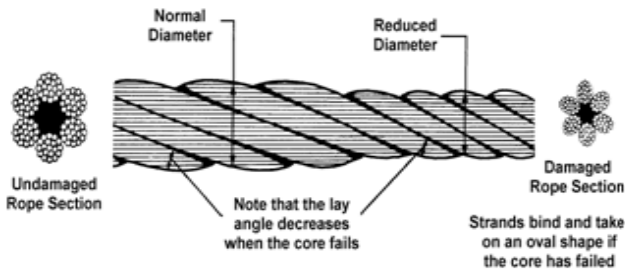

**Core Collapse**

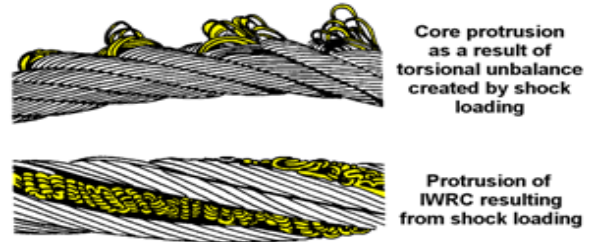

**Core Protrusion**

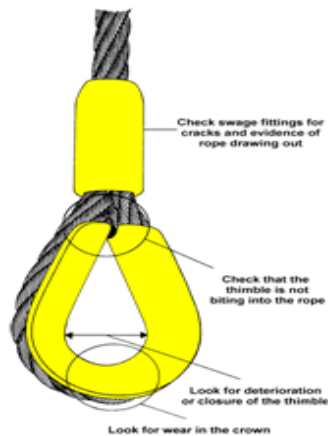

**Swaged Thimble Eye**



**High Stranding**  
(Only on non-rotating crane winch ropes)

## Broken Wires

To determine if a rope with broken wires is un-serviceable, the following should be considered:

- ▶ The rope must be replaced when the total number of broken wires exceeds 10% of the total number of wires in any given length equal to 8 rope diameters or 1 rope lay.
- ▶ A rope lay length is the distance that one strand takes to spiral 360° of the rope.

As the rope lays into a sheave friction occurs and the outside of the wires wear and become flat. Lang's lay ropes are much less prone to outer wire wear than ordinary lay.

As outer wires wear and the wire rope is bent over sheaves the fatigue caused will start to break them.

### Broken Wires Formula:

$$\frac{10\% \text{ of total wires}}{\text{over } 8 \times \text{rope diameter}}$$

The maximum number of broken wires allowed in a FSWR is 10 per cent of the total number of wires over a length 8 times the diameter of the rope.

### EXAMPLE:

Calculate the maximum allowable broken wires in a 20 mm FSWR with a construction of 6 x 19. Same as the diagram below.

Step 1. Calculate how many wires there are in the rope (6 x 19 = 114) now calculate 10% of that number of strands x number of wires in each strand x 10%

The formula is	$6 \times 19 \times 10\%$
Answer is =	11.4 wires (always round down) = 11 wires

Step 2. Calculate the distance to be used in checking. (i.e. diameter of rope x 8)

The formula is	$20 \text{ mm} \times 8$
Answer is =	160 mm

Therefore, when the number of broken wires is 11 over 160 mm of rope length, the rope must be condemned.



Condemn any FSWR showing broken wires in the valleys between the strands (an indication of extreme fatigue).

Condemn a FSWR where there is one broken wire at the start of any anchorage. This is a sign of localised fatigue.

If there are three or more broken wires in eight rope diameters the pendant rope should be inspected by a rope expert.

External wear on the individual wires is caused by friction.

Where the rope diameter has reduced to 85 per cent or less of the original diameter, the rope should be discarded even if there are no broken wires.

Fibre rope cores can be crushed and broken if the rope is bent over sheaves while the core is frozen. Under these conditions the FSWR can eventually lose its shape with serious internal corrosion.

The anchorage should be inspected. One broken wire at an anchorage condemns the rope at that point.

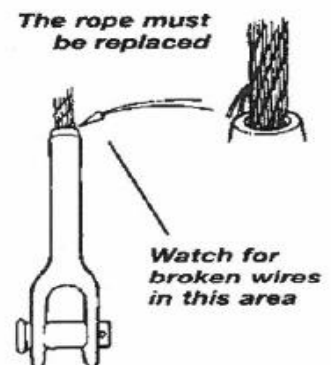

### Thimbles and Ferrules

Thimbles are used to create hard eyes, which provide greater strength and safety in hung scaffold operations by protecting the load bearing area inside the eye from distortion or chaffing.

Thimbles prolong the life of a sling as kinks or flattening in the lifting eyes are avoided.

A ferrule is used to make the eye in a rope and is positioned and pressed onto the FSWR. A defective swage fitting (ferrule) could involve tail slippage, a broken wire either side of swage, loose fitting thimble or ferrule.

The sling is then tested and the WLL is stamped on the ferrule.

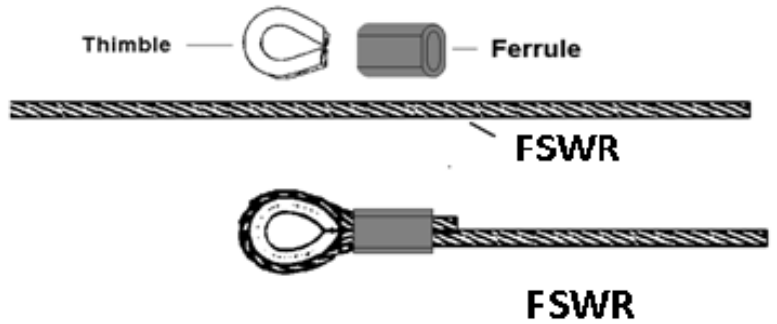

### Wire Rope Sling Protection

Must be used when applied to a square load.

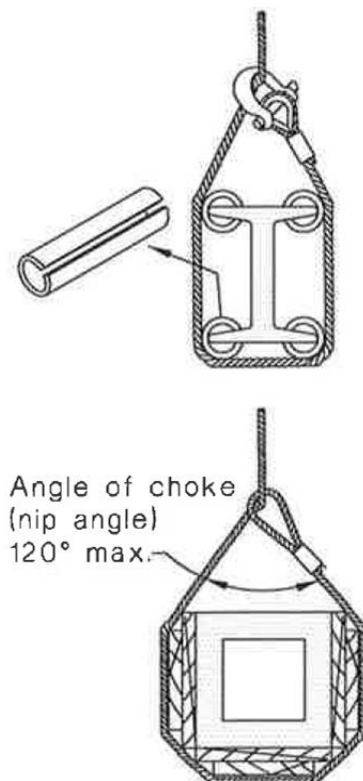
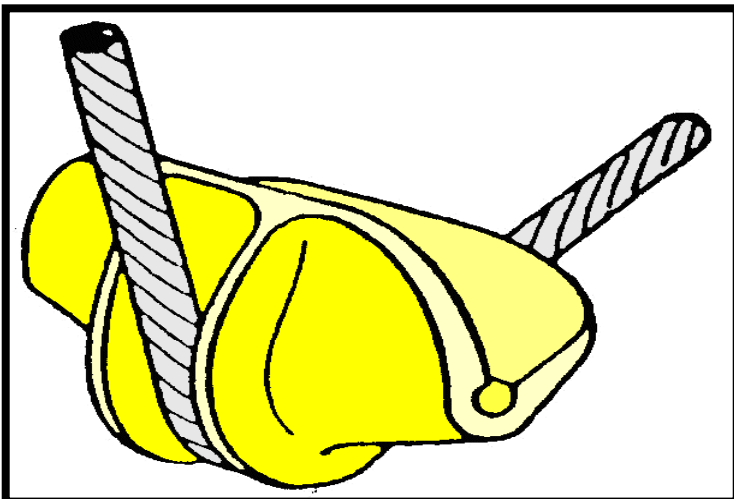

## Wedge Sockets / Bulldog Grips

The use of bulldog grips for hung scaffold or suspended scaffold operations is NOT permitted, except in the following application.

The use of bulldog grips for hung scaffold or suspended scaffold operations is NOT permitted, except in the following application.

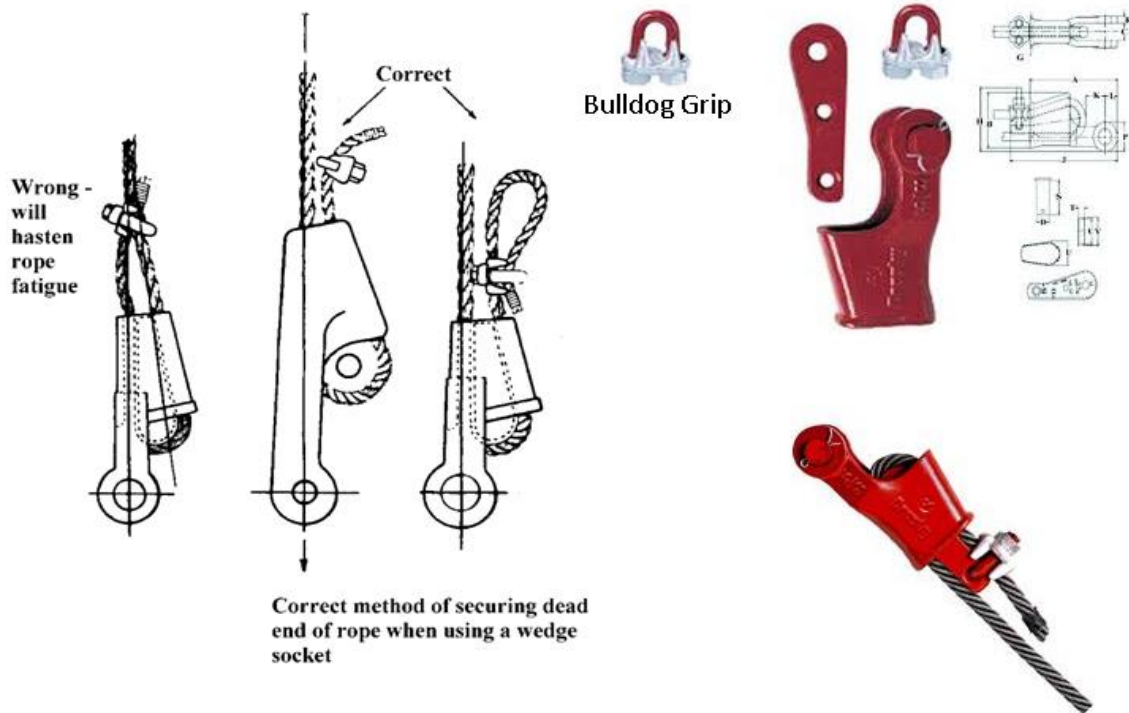

Wedge sockets must comply with AS 2740 Wedge-type sockets.

Wedge sockets are used to terminate the end of a wire rope.

Examples:

- ▶ Hung scaffold operations
- ▶ Guy ropes
- ▶ Static lines
- ▶ Span lines

There are many dangers associated with wedge-type sockets and **riggers** should ensure that they are set up correctly.

The advantages of using wedge rope sockets as anchorages are simplicity, ease and speed of applying and detaching, and that they do not damage the rope when fitted correctly.

The tail is approx. 200mm in length.

A wire rope grip must be applied to the tail (only) below the socket, a space of approx. 25mm is required, and acts as a slippage indicator.

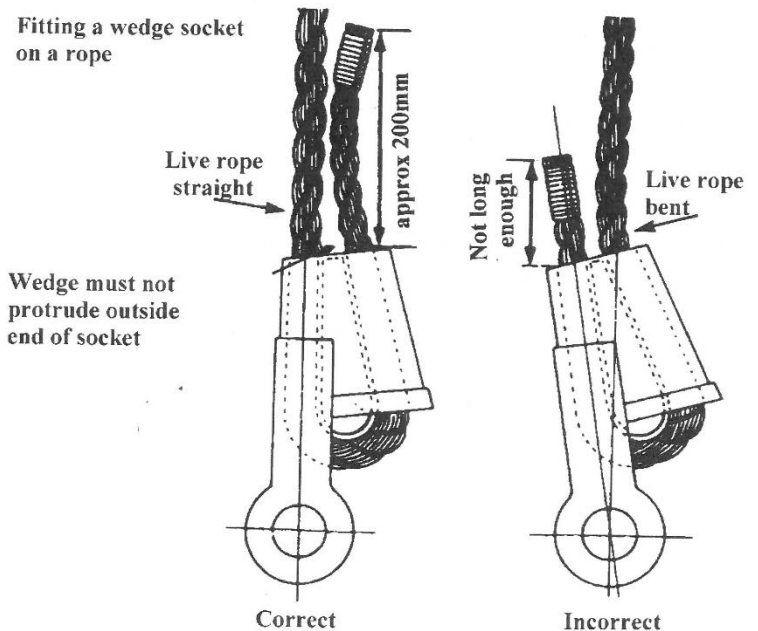





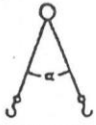

# WIRE ROPE SLINGS AS 1666

**1570 GRADE F.C.  
Single Leg**

**WORKING LOAD LIMIT (WLL)**

**1570 GRADE F.C.  
Two, Three and Four Leg**

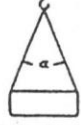
Method of Loading	Direct loaded	Choke Hitch		Basket Hitch				Direct loaded			Choke hitch	
		Round load	Rectangular load	Round Load		Other than round load						
						0° to 60°	90°				90°	120°
Included Angle $\alpha$	-	-	-	60°	90°	60°	90°	0° to 60°	90°	120°	0° to 45°	0° to 45°
Loading factors	1	0.75	0.5	1.73	1.41	0.87	0.71	1.73	1.41	1	1.30	0.87
Nominal rope diameter (mm)												
8	0.55	0.41	0.27	0.96	0.78	0.48	0.39	0.96	0.78	0.55	0.72	0.48
9	0.70	0.52	0.35	1.21	0.99	0.61	0.50	1.21	0.99	0.70	0.91	0.61
10	0.86	0.65	0.43	1.50	1.22	0.75	0.61	1.50	1.22	0.86	1.13	0.75
11	1.05	0.78	0.52	1.81	1.48	0.91	0.74	1.81	1.48	1.05	1.36	0.91
12	1.23	0.92	0.61	2.14	1.74	1.07	0.88	2.14	1.74	1.23	1.61	1.07
13	1.47	1.10	0.73	2.54	2.07	1.27	1.04	2.54	2.07	1.47	1.91	1.27
14	1.70	1.27	0.85	2.94	2.40	1.48	1.21	2.94	2.40	1.70	2.21	1.48
16	2.22	1.67	1.11	3.85	3.14	1.93	1.58	3.85	3.14	2.22	2.89	1.93
18	2.80	2.10	1.40	4.85	3.95	2.44	1.99	4.85	3.95	2.80	3.65	2.44
20	3.48	2.61	1.74	6.03	4.91	3.03	2.47	6.03	4.91	3.48	4.53	3.03
22	4.20	3.15	2.10	7.27	5.92	3.65	2.98	7.27	5.92	4.20	5.46	3.65
24	5.01	3.76	2.50	8.67	7.07	4.36	3.56	8.67	7.07	5.01	6.52	4.36
26	5.88	4.41	2.94	10.18	8.30	5.12	4.18	10.18	8.30	5.88	7.65	5.12
28	6.81	5.11	3.40	11.79	9.61	5.93	4.84	11.79	9.61	6.81	8.86	5.93
32	8.90	6.68	4.45	15.41	12.56	7.75	6.32	15.41	12.56	8.90	11.58	7.75

**1770 GRADE W.R.C.  
Single Leg**

**1770 GRADE W.R.C.  
Two, Three and Four Leg**

8	0.78	0.58	0.39	1.35	1.10	0.68	0.55	1.35	1.10	0.78	1.01	0.68
9	0.99	0.74	0.49	1.71	1.40	0.86	0.70	1.71	1.40	0.99	1.29	0.86
10	1.22	0.92	0.61	2.10	1.72	1.06	0.87	2.10	1.72	1.22	1.59	1.06
11	1.48	1.11	0.74	2.60	2.10	1.29	1.05	2.60	2.10	1.48	1.92	1.29
12	1.76	1.32	0.88	3.00	2.50	1.53	1.25	3.00	2.50	1.76	2.30	1.53
13	2.10	1.55	1.04	3.60	2.90	1.80	1.47	3.60	2.90	2.10	2.70	1.80
14	2.40	1.80	1.20	4.20	3.40	2.10	1.71	4.20	3.40	2.40	3.10	2.10
16	3.10	2.30	1.56	5.40	4.40	2.70	2.20	5.40	4.40	3.10	4.10	2.70
18	4.00	3.00	1.98	6.80	5.60	3.40	2.80	6.80	5.60	4.00	5.10	3.40
20	4.90	3.70	2.40	8.40	6.90	4.20	3.50	8.40	6.90	4.90	6.30	4.20
22	5.90	4.40	3.00	10.20	8.30	5.10	4.20	10.20	8.30	5.90	7.70	5.10
24	7.00	5.30	3.50	12.20	9.90	6.10	5.00	12.20	9.90	7.00	9.10	6.10
26	8.30	6.20	4.10	14.30	11.60	7.20	5.90	14.30	11.60	8.30	10.70	7.20
28	9.60	7.20	4.80	16.60	13.50	8.30	6.80	16.60	13.50	9.60	12.40	8.30
32	12.50	9.40	6.30	22.00	17.60	10.90	8.90	22.00	17.60	12.50	16.30	10.90
36	15.80	11.90	7.90	27.00	22.00	13.80	11.20	27.00	22.00	15.80	21.00	13.80
40	19.60	14.70	9.80	34.00	28.00	17.00	13.90	34.00	28.00	19.60	25.00	17.00
44	24.00	17.70	11.80	41.00	33.00	21.00	16.80	41.00	33.00	24.00	31.00	21.00
48	28.00	21.00	14.00	49.00	40.00	24.00	19.90	49.00	40.00	28.00	37.00	24.00
52	33.00	25.00	16.60	57.00	47.00	29.00	24.00	57.00	47.00	33.00	43.00	29.00
56	38.00	29.00	19.20	66.00	54.00	33.00	27.00	66.00	54.00	38.00	50.00	33.00
58	42.00	31.50	21.00	73.00	59.00	36.50	30.00	74.00	60.00	42.00	54.00	36.50
64	52.00	39.00	26.00	90.00	73.00	45.00	37.00	90.00	73.00	52.00	67.00	45.00
75	70.00	52.50	35.00	121.00	99.00	61.00	50.00	121.00	99.00	70.00	91.00	50.00

Nobles Big Lift Division has the capability to produce very large lifting slings in varying configurations. The Big Lift Division also has NATA accredited testing facilities to 1,000 tonne capacity.

If a FSWR sling is choked when applied to a hung scaffold, the maximum load that shall ne applied to the FSWR sling is 40% of its SWL.

## Scaffold Advanced Level Equipment (including Rigging Equipment)

### Beam Clamps

Beam clamps are used to attach slings that are supporting a hung scaffold to a steel beam (RSJ), in conjunction with FSWR, chains and shackles.



### Beam Trolleys

Beam trolleys are used to secure a scaffold to a beam or girder flange, also in conjunction with FSWR, chains and shackles. This allows the scaffold to move laterally (side to side).



### Synthetic Slings

#### All Lifting Equipment

All lifting equipment must be inspected prior to use and after use, by a competent person such as a dogman or rigger.

If any lifting equipment does not have a WLL tag or WLL stamp:

- ▶ Do not use
- ▶ Tag out of service
- ▶ Separate the item from other equipment (quarantine)
- ▶ Report to the supervisor

### Synthetic Slings

Under some conditions synthetic fibre rope can conduct electricity and therefore should not be used near powerlines.

#### Types

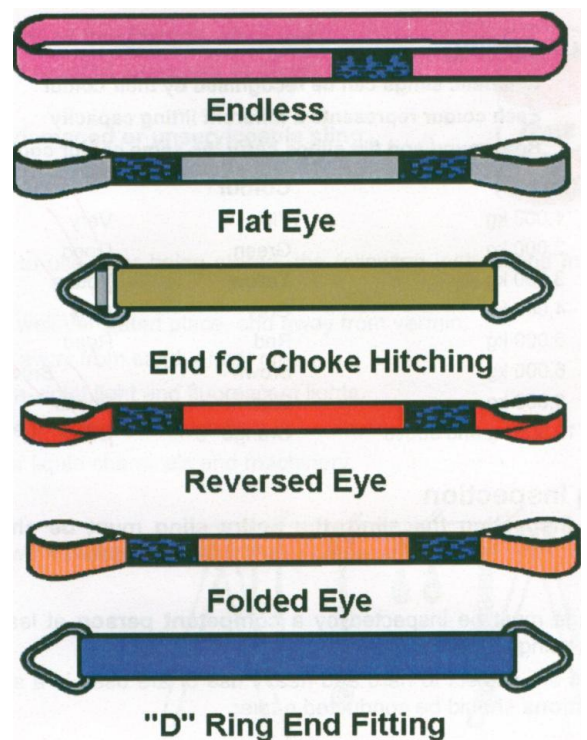
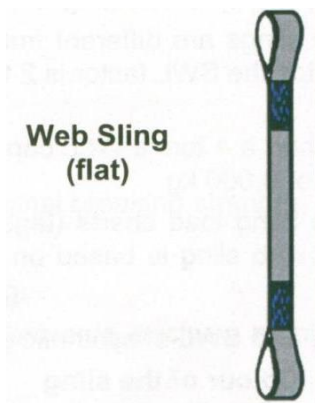

- ▶ All synthetic slings must have a Working Load Limit (WLL) Tag
- ▶ Synthetic slings come in two common types
- ▶ Round slings (rounded in shape)
- ▶ Web slings (flat shape)

Synthetic slings are made from nylon, polyester or arami polyamide.



## Configurations

Synthetic slings come in a variety of configurations, from endless or soft and hard eyes.

Round Synthetic Slings - AS 4497.2 and Flat Webbing Slings - AS 1353.2											
Safe working loads under general conditions of use											
Method of Loading	Basket Hitch						Two leg, three leg and four leg slings				
	Straight Lift	Choked Lift	Parallel							Choke Hitch	
										Single Wrap	Double Wrap
Included Angle ( $\beta$ )	N/A	N/A	N/A	60°	90°	120°	0° to 60°	90°	120°	0° to 45°	0° to 60°
Loading Factor (L)	1	0.8	2	1.73	1.41	1	1.73	1.41	1	1.38	
WLL in basic configuration (tonnes)	Safe working load (tonnes)										
1 (Violet)	1	0.8	2	1.7	1.4	1	1.7	1.4	1	1.3	
2 (Green)	2	1.6	4	3.4	2.8	2	3.4	2.8	2	2.7	
3 (Yellow)	3	2.4	6	5.1	4.2	3	5.1	4.2	3	4.1	
4 (Grey)	4	3.2	8	6.9	5.6	4	6.9	5.6	4	5.5	
5 (Red)	5	4.0	10	8.6	7.0	5	8.6	7.0	5	6.9	
6 (Brown)	6	4.8	12	10.3	8.4	6	10.3	8.4	6	8.2	
8 (Blue)	8	6.4	16	13.8	11.2	8	13.8	11.2	8	11.0	
10 (Orange)	10	8.0	20	17.3	14.1	10	17.3	14.1	10	13.8	
12 (Orange)	12	9.6	24	20.7	16.9	12	20.7	16.9	12	16.5	

## Precautions with Synthetic Slings

- ▶ A synthetic sling should not be twisted when lifting loads as it will decrease its WLL.
- ▶ All slings should be protected around a sharp corner
- ▶ AS 1353.2 states that a sharp corner for a synthetic sling is deemed to be a corner with a radius less than three times the compressed thickness of the sling
- ▶ Care also need to be taken to prevent damage to the outside of the sling whilst under load, e.g. impact with an adjacent structure (steel or concrete) can quickly cut through the sling
- ▶ Slings should be protected inside and outside with a sleeve

## Inspection

Synthetic slings must be inspected before each use. They must also be inspected at least once every three months by a competent person. If a sling is subject to severe conditions the inspections should be more frequent. Send each sling for a proof load test at least every 12 months.

Look for:

- ▶ Any external wear such as abrasion or cuts and contusions
- ▶ Internal wear which is often indicated by a thickening of the sling or the presence of grit and dirt
- ▶ Damage to any protective coating of the sling
- ▶ Damage caused by high temperatures, sunlight or chemicals (indicated by discolouration)
- ▶ Damage to the label or stitching
- ▶ Damage to the eyes or any terminal attachments or end fittings
- ▶ Where the sling is covered by a sleeve, the sleeve must cover the sling for the full length from eye to eye

Discard a synthetic sling if:

- ▶ The label has been removed or destroyed
- ▶ There is any damage to the sleeve or protective coating
- ▶ A nylon sling comes into contact with acid
- ▶ A polyester sling comes into contact with alkaline substances
- ▶ A polypropylene sling comes into contact with an organic solvent such as paint, coal tar or paint stripper
- ▶ There are any visible cuts on the sling

**Note:** A nylon sling will lose more than 10 per cent of its strength when it is wet.

After six months continuous exposure to sunlight send a sling in for testing, to the manufacturer.

Synthetic slings must be stored:

- ▶ In a clean, dry, well ventilated place
- ▶ Away from the ground or floor
- ▶ Away from direct sunlight, ultra-violet light and fluorescent lights
- ▶ Away from extremes of heat
- ▶ Away from sources of ignition
- ▶ Away from atmospheric or liquid chemicals
- ▶ Away from the possibility of mechanical damage

The working life of synthetic slings will be shortened if exposed to any of the above.

## Tags

When inspecting synthetic slings, the tag must be in good condition and legible. The information displayed on the tag includes;

- ▶ WLL
- ▶ Angle factors
- ▶ Reeve factors
- ▶ AS/NZ (Aust/NZ Standard)
- ▶ Serial number
- ▶ Manufacturer
- ▶ Grade/applications
- ▶ Conditions of use
- ▶ Length



## Colour Coding

Some synthetic slings are colour coded; in no way can these colours be relied upon to determine the actual WLL. The colour coding is an indicator only.

## Chain Slings

This section deals with:

- ▶ Lifting material types.
- ▶ SWL calculations.
- ▶ Chain sling assemblies.
- ▶ Advantages and disadvantages of chain.
- ▶ Inspection and storage.

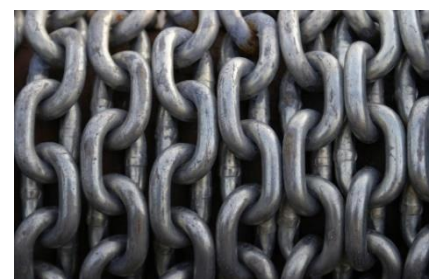

## Some Types of Chain

### Short Link Chain (Un-calibrated) (lifting)

Short link chains may be used to support hung scaffolds. The barrel of short link chain requires a greater force to bend, provides greater strength, reduces the tendency to twist and provides better reeving performance.

These chains must be Grade T and not less than 8mm in diameter. Grade markings or letters denoting the grade are stamped or embossed on the chain at least every metre or every 20 links, whichever is less.

The size of the chain is determined by the material in the actual link. Short link chain is made in short links to provide greater strength. The link length will not exceed 5 times the diameter of the link material long nor 3.5 times the diameter width.

Chains should be checked before and after use to make sure they are in safe working condition.

The checklist below outlines what you are looking for. If a chain shows any of these then it is unsuitable for use.

Possible Chain defects:	
Missing or illegible rated capacity tag.	Incompatible grade and diameter components.
Twists and/or kinks and/or knots.	Squashed/crushed more than 10% of original link diameter.
Cracks in link welds, spot-welding.	Gouged/cut more than 10% of original link diameter.
Exposure to excessive heat.	Severe/excessive rust or corrosion.
Pitting.	Stretching, locked, movement restricted.
Excessive wear on chain (over 10% wear in link diameter).	

### Calibrated

Pitch short link chain has the link sides parallel to prevent stretch under load and is pitched so that the links are a constant and accurate length.

Pitched chain must ride smoothly and be a working fit in the groove of a sheave or drum or the pockets of a load sheave (gypsy) hence any stretch may cause “riding” and slip. Pitched or calibrated chain is principally used on chain blocks.

The outside dimensions of the links of calibrated chain are as follows:

- ▶ Length will not exceed 6 times the diameter of the material used.
- ▶ Width will not exceed 3.5 times the diameter of the material used.

The welds must be smoothly finished free from fins or flashes. The diameter of the weld must not exceed the diameter of the material from which the chain is made.

### Stud Link Chain

Stud link chain has a stud across the centre of each link. It is unsuitable for general lifting purposes and is used mostly for marine purposes.

### Mild Steel Grade

The links are electrically machined welded at mid length of one side with weld area swollen and dressed slightly larger than the normal diameter. Grade L replaced the “old” Grade 30. It is stamped on each 20<sup>th</sup> link or at 1 metre intervals. Grade (L) or 30 mild grade steel can be stamped (L), 30 or 3.

### Chains NOT used for Hung Scaffold

- ▶ Grade 75 (transport lashing chain)
- ▶ Wrought Iron Chain (decorative, swords, axes and cutlery)
- ▶ Proof coil chain (fencing)
- ▶ Mild steel chain (commercial galvanised chain from a hardware store)
- ▶ Approved grade chains under the allowable diameter



### Chains USED for Hung Scaffold

All chains used for lifting must have a WLL tag.

Always check that the grade on the tag matches the grade markings on the chain, a minimum 80(T)

Each chain sling must have a tag stating manufacturer, grade, SWL of different applications and conditions of use.

**The letters L, M, P, T and V are most commonly used as identifying marks on the respective grades of lifting chain.**

Chains are manufactured in various grades although the most common chain used for lifting is grade 80T, with some grade 100 chain also used for hung scaffold.

The lesser grades of chain must never be used for hung scaffold.

The minimum diameter is 8mm and the grade is 80(T) chain used for hung scaffold operations. Lifted below are the main grades manufactured;

Material	Grade	Manufacturer's ID
Mild Steel	30	L, 30 (not lifting chain)
Mild Steel	40	M, 40 (not lifting chain)
Alloy	50	P, 50 (not lifting chain)
Alloy	60	S, 60 (not lifting chain)
Alloy	80	T, CM, 800, 80, 8 (lifting chain) & hung scaffolding (min)
Alloy	100	V, 10 or 100 (lifting chain) & hung scaffolding

The grade and manufacturer's ID can be found stamped on links throughout the length of the chain. Some are marked every link while others are marked every 20th link or every 1 metre whichever comes first. Markings on a lifting chain indicates the grade of the chain.

### Grade T

Most chain being manufactured today for lifting is Grade (T) or 80 alloy steel. It is stamped (T), 800, 80, 8 or HA PWB, or CM and various combinations of the above. It has become the most commonly used chain for lifting in the industry and hung scaffolding operations.

### GRADE MARKINGS



## Chain Sling Assembly



A single chain sling assembly is made up of five major components:

- ▶ Ring
- ▶ SWL tag
- ▶ Two hammerlocks
- ▶ The chain length

Lifting chains which have the SWL tag missing should not be used and returned to the supplier or manufacturer for testing and replacing.

Chain slings should be made up to AS 3775 Chain slings - Grade T or the manufacturer's recommendations. When ordering parts for chain slings ensure that they comply with the appropriate Standard.

Avoid making up slings from different grades of chain or fittings. Try to use only one grade of chain throughout the workplace. This will prevent confusion about the WLL of slings for given diameter chain slings, especially if a WLL tag is missing.

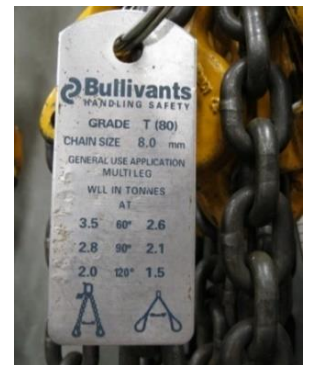

The chain, large oblong link, hammerlocks or couplers should all be of equal capacity or grade. Riggers should have the knowledge and expertise to inspect a chain sling to ensure that the grade and safe working load of all components match.

**Inspect ALL lifting gear BEFORE and AFTER use to ensure it is safe to use.**

**This is done by a competent person such as a dogman or rigger.**

**A CHAIN SLING IS ONLY AS STRONG AS ITS WEAKEST LINK**

- ▶ Never use excessively pitted, corroded, unduly worn, deformed, chipped, nicked, cracked or otherwise damaged chain, also if the SWL/WLL tag is missing or unreadable.
- ▶ The maximum temperature for mild steel chain to be used is 260° C (below red heat). HERC ALLOY 400° C.

When making up a sling, always use chain, links and hammerlocks or couplers of the same grade and SWL and that are in good state of repair.

- ▶ **Do not** apply a load heavier than the SWL of the chain
- ▶ **Do not** use a chain in which the links are stretched, frozen or do not move freely.
- ▶ **Do not** use a chain that is gouged or worn more than 10% of the diameter.
- ▶ **Do not** twist kink or knot chain.
- ▶ **Do not** roll loads over a chain.
- ▶ **Do not** use a chain with a link that is cracked, or that has been spot welded other than by the manufacturer.
- ▶ Use protective padding when using chain around sharp corners.

## Inspection and discard

- ▶ Inspect your chain slings regularly.
- ▶ If necessary clean the chain before inspection.
- ▶ The maximum allowable chain wear is 10%.
- ▶ The maximum allowable elongation of a chain is 10%.
- ▶ Inspect each link for signs of wear, twisting, stretching, nicks or gouging.
- ▶ Links that are frozen together show that the chain has been stretched.
- ▶ Find cracks by dusting chain with fine powder. Dust any link that is suspect and then blow the loose particles away. Dust particles will lodge in any cracks making them more visible. Magnetic particles can also be used.

- ▶ Measure all worn links for the degree of wear. Wear must not exceed that allowed for by the manufacturer.
- ▶ Inspect upper and lower terminal links for signs of wear at their load bearing points and for any signs of distortion.
- ▶ Inspect links and fittings for signs of wear at their load bearing points and for excessive play in the load pin between the body halves.

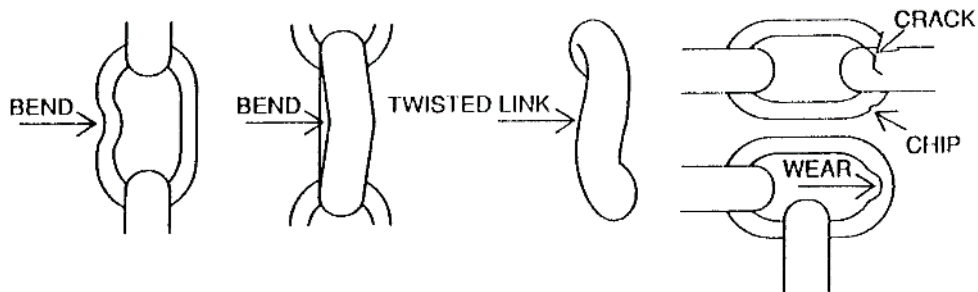

### Defective Chain

- ▶ Withdraw any chain from service immediately if it has defects.
- ▶ Clearly mark the chain with a tag stating that it must not be used until it has been inspected by the manufacturer.
- ▶ Destroy any chain that cannot be repaired, when authorised.
- ▶ If the chains SWL/ WLL tag is not legible or tag is missing, you must:
  - Tag out of service.
  - Must be removed from service and quarantined.
  - Report to supervisor.
- ▶ Follow site procedures.
- ▶ Enter all inspection details on the rigging matrix.

### Care and Maintenance of Chain







- ▶ Do not overload chain
- ▶ Do not use a chain with locked or stretched links or which has links that do not have free movement
- ▶ Do not hammer a chain to straighten a link or force a link into position
- ▶ Do not use an excessively pitted, corroded, unduly worn, deformed, chipped, nicked, cracked, or otherwise damaged chain
- ▶ Do not snatch or jerk loads being handled by chain slings, especially in cold weather. Sudden loading can have the effect of doubling the load in the sling. Chain and chain slings should not be used in temperatures below  $-20^{\circ}\text{C}$  as this extreme cold could make chain brittle
- ▶ Do not cross, twist, kink or knot chain
- ▶ Do not drag a chain by force from under a load
- ▶ Do not drop a chain from a height
- ▶ Do not roll loads over a chain
- ▶ Do not use a chain over sharp edges without proper packing on the edges. Hessian bagging is not good enough. Use cut lengths of rubber car tyre, half rounds of tube or timber. All packing should be secured when sending loads aloft. When the load is landed the slings go slack and the packing can drop out resulting in a potential dropped object.
- ▶ Do not use lifting chain at temperatures over  $400^{\circ}\text{C}$  without consulting the manufacturer. Lifting chain used at temperatures over  $200^{\circ}\text{C}$  requires derating. Refer to table for the reduction factor.

Temperature Range °c	Temporary Reduction of WLL while heated
Up to 200	Nil
200-300	10%
300-400	25%
Over 400	Do Not Use

- ▶ Do not place the links of a chain so that they bear on the hook of a crane or hoist (except an endless chain sling)
- ▶ Do not join chain by using a bolt or a bulldog grip
- ▶ Do not shorten a chain by twisting or wrapping it around a hook
- ▶ When not in use all chain lifting gear should be stored on racks or pegs, under cover
- ▶ Any screw thread used in connection with chain blocks must be securely locked
- ▶ Any repairs to chain should be referred back to the manufacturer or supplier
- ▶ Do not use chain in corrosive environments without reference to the manufacturer

### 'T' Grade Chain Table (80 grade)







**TABLE 1**  
**WORKING LOAD LIMIT (GRADE T)\***

Chain size mm	Working load limit under general conditions of use, t								
	Single leg slings				Slings of 2, 3 or 4 legs			2 leg slings	
	 Straight sling or adjustable sling with no deration	 Adjustable sling with deration see Note 1	 Reeved sling	 Basket sling Max 60°	 Straight sling see Note 2	 Reeved sling see Notes 2 and 3	 Basket sling see Notes 2, 3 and 4	60°	90°
Loading factors	1	0.75	0.75	1.3	1.73	1.41	1	1.3	2.25
Chain size, mm									
6	1.1	0.8	0.8	1.5	1.9	1.6	1.1	1.5	2.5
7	1.5	1.1	1.1	2	2.6	2.1	1.5	2	3.4
8	2	1.5	1.5	2.6	3.5	2.8	2	2.6	4.5
10	3.2	2.4	2.4	4.1	5.5	4.5	3.2	4.1	7.2
13	5.3	4.0	4.0	6.9	9.2	7.5	5.3	6.9	11.9
16	8	6.0	6.0	10.4	13.8	11.3	8	10.4	18.0
19	11.2	8.4	8.4	14.6	19.4	15.8	11.2	14.6	25.2
20	12.5	9.4	9.4	16.3	21.6	17.6	12.5	16.3	28.1
22	15	11.3	11.3	19.5	26.0	21.2	15	19.5	33.8
26	21.2	15.9	15.9	27.6	36.7	29.9	21.2	27.6	47.7
32	31.5	23.6	23.6	41	54.5	44.4	31.5	41	70.9

If a chain sling is choked when applied to a hung scaffold, the maximum load that shall be applied to the chain sling in 40% of its SWL.

## 'V' Grade Chain Table (100 grade)

**TABLE 2**  
**WORKING LOAD LIMIT (GRADE V)\***

Chain size mm	Working load limit under general conditions of use, t								
	Single leg slings				Slings of 2, 3 or 4 legs			2 leg slings	
									
Straight sling or adjustable sling with no deration	Adjustable sling with deration see Note 1	Reeved sling	Basket sling Max 60°	Straight sling see Note 2			Reeved sling see Notes 2 & 3	Basket sling see Notes 2, 3 & 4	
Loading factors	1	0.75	0.75	1.3	60°	90°	120°	Max angle 60°	Max angle 60°
Chain size, mm									
4	0.63	0.5	0.4	0.8	1.1	0.9	0.63	0.8	1.4
5	1	0.8	0.6	1.3	1.7	1.4	1	1.3	2.3
6	1.4	1.1	0.8	1.8	2.4	2.0	1.4	1.8	3.2
7	1.9	1.4	1.1	2.5	3.3	2.7	1.9	2.5	4.3
8	2.5	1.9	1.4	3.3	4.3	3.5	2.5	3.3	5.6
10	4	3.0	2.3	5.2	6.9	5.6	4	5.2	9.0
13	6.7	5.0	3.8	8.7	11.6	9.4	6.7	8.7	15.1
16	10	7.5	5.6	13.0	17.3	14.1	10	13.0	22.5
18	12.5	9.4	7.0	16.3	21.6	17.6	12.5	16.3	28.1
19	14	10.5	7.9	18.2	24.2	19.7	14	18.2	31.5
20	16	12.0	9.0	20.8	27.7	22.6	16	20.8	36.0
22	19	14.3	10.7	24.7	32.9	26.8	19	24.7	42.8
23	21	15.8	11.8	27.3	36.3	29.6	21	27.3	47.3
26	26.5	19.9	14.9	34.5	45.8	37.4	26.5	34.5	59.6
28	31.5	23.6	17.7	41.0	54.5	44.4	31.5	41.0	70.9
32	40	30.0	22.5	52.0	69.2	56.4	40	52.0	90.0

Packing such as wooden blocks may be required where a chain comes into contact with a square load, to protect the chain and the load from damage. Sharp corners of metal or other hard material can bend or damage chain links. The chain can damage the load by high contact pressure.

The working load limit tag must be fixed on all chain assemblies, the tag must detail the SWL under all conditions of loading.

If a tag is missing the sling should be taken out of service, unless the necessary information is marked on the master link. Once the tag is replaced the sling can immediately be returned to service. The tag should be replaced by a competent person.

Coupling links, often branded Hammerlok or Kuplex are used to connect alloy chain to alloy rings and hooks. Make sure that the pin connecting the two halves is firmly in position and that there are no cracks running from the inside corners of the forked part of the links.

Twist the spacer in the centre of the link to ensure that it is free. A jammed spacer is a sign that the chain has been overloaded.

### Working Load Limit (WLL)

The WLL of a chain sling is the direct load configuration.

Once the sling changes, in any way, from this configuration the Safe Working Load (SWL) governs sling capacity.

## Sling Arrangements and Sling Factors

### Single leg reeveable sling

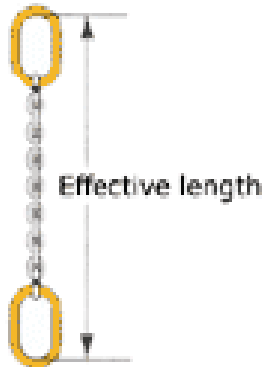

This section deals with sling configuration, common sling arrangements, sling angles and sling load factors and attachment factors.

“LIFTING SLINGS” are detachable lifting gear made from Flexible Steel Wire Rope (FSWR) and chain. Sling lifting gear is made by many manufacturers throughout Australia and overseas. The Australian manufacturers produce lifting gear to the highest quality standards available, i.e.: to Australian Standards. The life of a manufactured sling can be dramatically extended by the rigger and dogman, and scaffolder when authorised who follow the rules for safe use, inspection and storage of lifting gear.

Proper use and handling will also provide user and operators a safety insurance against premature failure. E.g. to prevent sling damage from sharp edges of loads use packing, lagging or dunnage.

All lifting tackle must be inspected prior to use and in addition, a periodic recorded inspection must be conducted by qualified personnel e.g. Dogger, Rigger.

### Storing Lifting Equipment

It should be stored in a place that is:

- ▶ Clean
- ▶ Dry
- ▶ Well ventilated
- ▶ Out of direct sunlight, ultraviolet light or fluorescent lighting
- ▶ Under cover
- ▶ Off the floor
- ▶ Away from chemicals
- ▶ Away from oils
- ▶ Away from sand/grit
- ▶ Away from machinery
- ▶ Vermin free
- ▶ In accordance with manufacturers specifications

### Special Note:

If any component is found to be faulty it must be withdrawn from use:

1. Do not use
2. Tagged out of service
3. Report to your supervisor
4. Quarantine equipment
5. Update rigging matrix

**Slings which cannot be repaired must be destroyed with approval from your supervisor and recorded.**

LOADING OF CONNECTING LINKS TO FORM A BASKET SLING

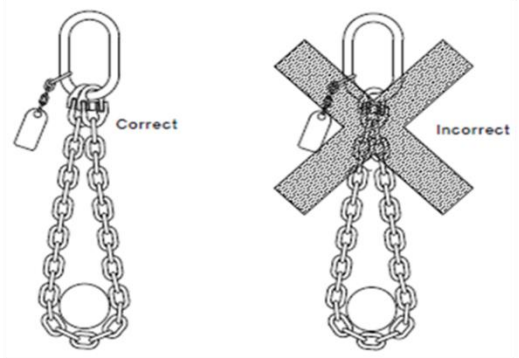

## Sling/Lifting Attachments

Lifting attachments cover all equipment used in the connection of lifting slings to a load and cover a wide variety of items, they include:

- ▶ “Dee” and “Bow” shackles
- ▶ Lifting eyes or eyebolts

## Shackles

Shackles are a portable link, used for joining various pieces of lifting equipment.

The two main shapes for load lifting are:

- ▶ Dee Shackle
- ▶ Bow Shackle

“Dee” and “Bow” shackles are mostly used to connect a sling or slings to the load or the crane hook, however they can also be utilised to install either hung or suspended scaffolding.

Although all “Dee” and “Bow” shackles may look similar **ONLY CERTIFIED** shackles must be used when lifting.

Certified shackles have a larger diameter pin than, commercial grade shackles.

Commercial grade shackles are a mild steel shackle you would purchase from a hardware store e.g. Bunnings etc.

Almost all shackles are made of round bar and have circular eyes. The pin of the common shackle screws directly into one eye and should preferably have a collar. In some shackles, the pins pass clear through both eyes and are secured by a split pin forelock (i.e. split flat cotter pin) or nut and split pin.

The pin diameter on certified shackles are usually larger than the shackle body diameter – making them easily identifiable (see diagram below).

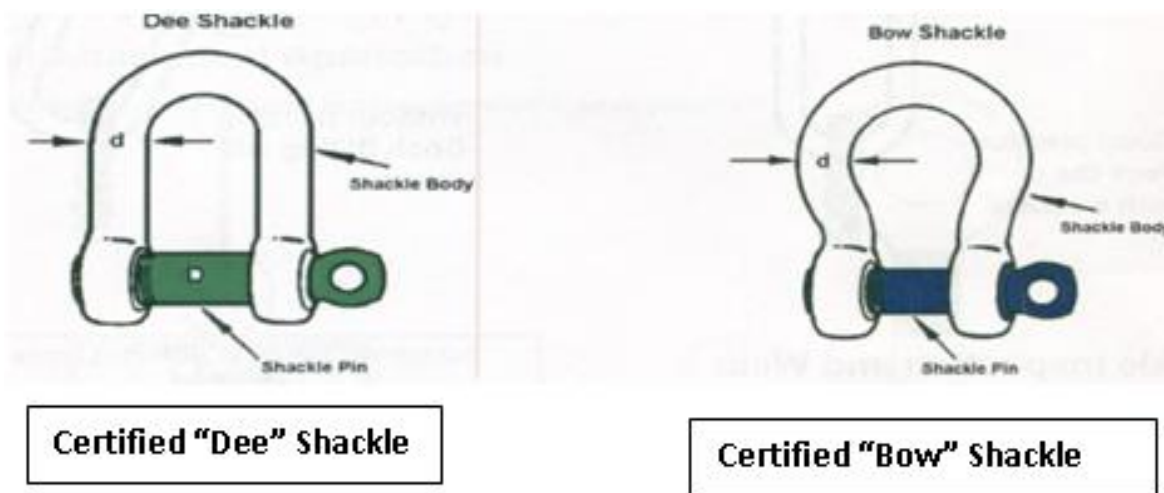

Although very similar in appearance both types of certified shackles shown above are used for different applications.

Shackles are made to AS 2741 Shackles. The grades range from grades L and M for small dee and bow shackles to grades S and T for large dee and bow shackles.

To eliminate projections, shackle pins are sometimes counter sunk flush with the eyes.

The pin and forelock shackle is a safe shackle but is mainly used for standing rigging such as guys.

Always use the correct size shackle pin. Do not use a nut and bolt in place of the proper shackle pin. A pin that does not fit tightly is likely to bend and break.

Screw shackle pins should be tightened then loosened very slightly, so that the shackle pin can be unscrewed when the weight is released. If the pins are tightened and the strain is taken on the shackle the pin often jams and is difficult to unscrew (back off a ¼ of a turn).

Where shackles are subject to vibration, mouse the shackle pin to prevent the pin from unscrewing.

Shackles are designed to take vertical forces only. Diagonal forces will strain the shackle and lead to eventual failure.

If any small object such as a single sling or another shackle is placed on the pin the shackle will 'cock bill' or can't. To stop this happening, pack the shackle pin with washers or ferrules to keep the load in the centre of the pin.

When using multiple slings, always use a bow shackle large enough to accommodate all the eyes safely on the bow. The pin of the shackle should rest on the hook.

Do not use an un-moused screw shackle where the pin can roll under load and unscrew.

Shackles must be branded with the WLL. Do not use a shackle without the WLL clearly marked, for load lifting.

Knocking and leverage can cause vibration which works the pin out of the shackle. To prevent this use the forelock, or the pin with the nut and cotter pin.

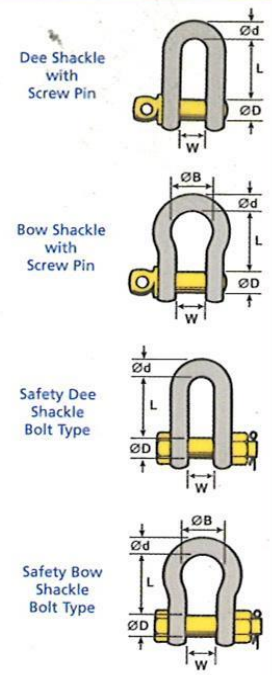
Alloy Grade 'S' Shackles								WITH YELLOW PAINTED PIN TO AS2741-2002 AUSTRALIAN STANDARDS	
WORKING LOAD LIMIT Metric Tonnes	DIA. d mm	DIA. PIN D mm	INSIDE WIDTH W mm	INSIDE LENGTH DEE TYPE L mm	BOW TYPE L mm	WIDTH OF BOW B mm	APPROX. WEIGHT EACH SCREW PIN kg	SAFETY PIN kg	
0.33	5	6	10	—	22	15	0.02	—	
0.50	6	8	12	22	29	20	0.06	0.07	
0.75	8	10	13	26	31	21	0.11	0.13	
1.00	10	11	17	32	37	26	0.15	0.17	
1.50	11	13	18	37	43	29	0.21	0.25	
2.00	13	16	21	41	48	33	0.37	0.44	
3.20	16	19	27	51	61	43	0.65	0.79	
4.70	19	22	32	60	72	51	1.06	1.26	
6.50	22	25	37	71	84	58	1.56	1.88	
8.50	25	29	43	81	95	68	2.32	2.78	
9.50	29	32	46	90	108	74	3.28	3.87	
12.00	32	35	52	100	119	83	4.51	5.26	
13.50	35	38	57	113	133	92	5.43	6.94	
17.00	38	41	60	124	146	98	7.89	8.79	
25.00	44	51	73	146	178	127	13.40	14.99	
35.00	51	57	83	171	197	146	18.85	20.65	
45.00	57	63	95	181	222	160	26.06	29.01	
55.00	63	70	105	203	267	184	37.86	41.05	
85.00	76	83	127	229	330	200	58.68	62.24	
120.00	89	95	146	267	381	241	—	110.00	
150.00	102	108	165	318	432	279	—	160.00	

OTHER SIZES UP TO 1000 TONNES AVAILABLE ON REQUEST

### Shackle Application

Shackles have many applications in lifting operations. Remember the basic safety practices require them to be used as directed by the manufacturer or as follows.

- ▶ **Always pack either side** of a shackle pin if being used on a hook (prevents Cock Billing).
- ▶ A “Dee” shackle is designed primarily for single sling application.
- ▶ A bow shackle is designed primarily for use with multi sling applications.

- ▶ If a shackle has the smallest SWL in the lifting assembly, then the SWL of the whole assembly is that of the shackle.
- ▶ **Do not over tighten the pin**; this is best achieved by using your hands to tighten, then back off quarter of a turn to prevent pin from locking.
- ▶ **Always replace the pin in the same shackle** body, do not mix as different material grades could result in shackle failure and is against regulations.
- ▶ Ensure shackles or lifting rings hang freely on hooks.
- ▶ Always refer to the manufacturer's SWL guide to gain the SWL of a shackle.
- ▶ SWL/WLL must be stamped on the body of the shackle.
- ▶ When using a shackle for a hung scaffold, the maximum load that shall be applied to the shackle is 80% of its SWL.

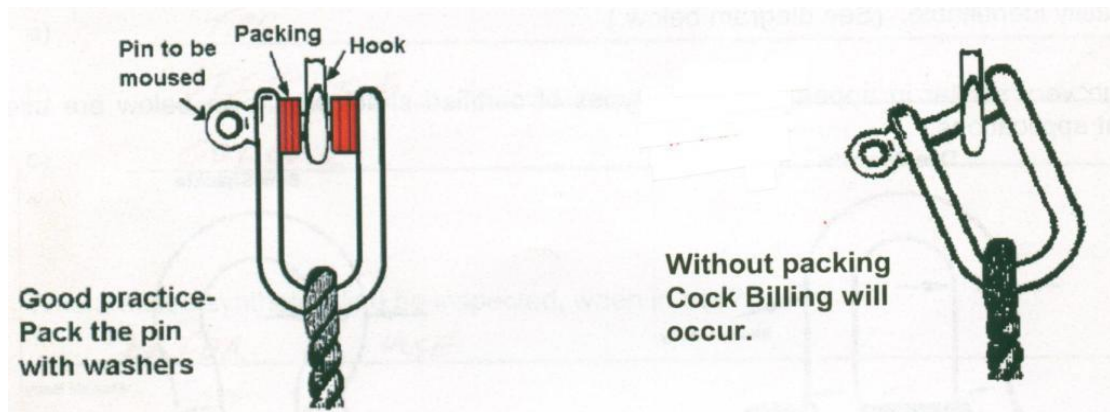

### Shackle Inspection and Wear Inspection

- ▶ Inspect shackles before and after use.
- ▶ A certified shackle is one which is stamped with its SWL, and
- ▶ The pin is a larger diameter than the body of the shackle.

### Wear and Damage

- ▶ WLL not legible or missing
- ▶ After inspecting a shackle if the wear is greater than 10% either on the pin or body, the shackle must not be used, if in doubt consult your supplier.
- ▶ All unserviceable shackles must be disposed of correctly and not made available for use.
- ▶ Damage to shackles could involve being;
  - ◆ Cracks and chips
  - ◆ Bent or warped
  - ◆ Stretched pin
  - ◆ Incorrect pin
  - ◆ Pin won't screw in and/or retaining pin is missing
  - ◆ Cuts
  - ◆ Gouged

*Refer to manufactures specifications for more information.*

Condemn a shackle which is worn either in the crown or on the pin by more than 10% of its original diameter.

Do not use a shackle or pin which is bent, strained, deformed or damaged. Tiny microscopic cracks may have developed during deformation. These can extend under quite small loads and lead to complete failure.

## Identify Safety Equipment Requirements

Depending on the requirements of the job, you may need to use safety equipment to reduce the risk to an acceptable level.

Safety equipment includes:

- ▶ Safety harness.
- ▶ Lanyard.
- ▶ Inertia reel.
- ▶ Energy absorber.

All safety equipment should be selected at the planning stage.

Safety equipment needs to be inspected before and after use.

## Various Safety Equipment

### Safety Harnesses

In most cases of working at heights a full body harness should be worn.

Harnesses must be correctly fitted in accordance with the manufacturer's instructions to ensure effectiveness.

Workers should connect the fall-arrest line to the attachment point on their harness (dorsal attachment point in the middle of the back, or the chest connection) that will provide the best protection in the situation it is being used.

Safety harnesses must meet the requirements of AS/ NZS 1891 Industrial fall-arrest systems and devices.

A fall-arrest harness must be inspected before use.

Common defects that will condemn a safety harness from use are:

- ▶ Missing or un-readable manufactures tag
- ▶ Expiry date has lapsed
- ▶ Any obvious signs of damage to any part of the harness, including hardware
- ▶ Fraying
- ▶ Splitting

Shown here are some examples of some things you need to check the harness for:

Component	Condition/fault to be checked
<b>Webbing</b>	<ul style="list-style-type: none"> <li>▶ Cuts or tears.</li> <li>▶ Abrasion damage.</li> <li>▶ Excessive stretching.</li> <li>▶ Damage due to contact with heat, corrosives or solvents.</li> <li>▶ Deterioration due to rotting, mildew, or ultraviolet exposure.</li> </ul>
<b>Snap Hooks</b>	<ul style="list-style-type: none"> <li>▶ Distortion of hook or latch.</li> <li>▶ Cracks or forging folds.</li> <li>▶ Wear at swivels and latch pivot pin.</li> <li>▶ Open rollers.</li> <li>▶ Free movement of the latch over its full travel.</li> <li>▶ Broken, weak or misplaced latch springs (compare if possible with a new snap hook)</li> <li>▶ Free from dirt or other obstructions, e.g. rust.</li> </ul>

Component	Condition/fault to be checked
<b>D-rings</b>	<ul style="list-style-type: none"> <li>▶ Excessive 'vertical' movement of the straight portion of the D-ring at its attachment point of the belt, so that the corners between the straight and curved sections of the D become completely exposed. <b>NOTE:</b> Excessive vertical movements of the D-ring in its mounting can allow the nose of larger snap hooks to become lodged behind the straight portion of the D, in which position the snap hook can often accidentally 'roll out' of the D under load.</li> <li>▶ Cracks, especially at the intersection of the straight and curved portions.</li> <li>▶ Distortion or other physical damage of the D-ring.</li> <li>▶ Excessive loss of cross-section due to wear.</li> <li>▶ Pitting/ rust.</li> </ul>
<b>Buckles and adjusters</b>	<ul style="list-style-type: none"> <li>▶ Distortion or other physical damage.</li> <li>▶ Cracks and forging laps where applicable.</li> <li>▶ Bent tongues.</li> <li>▶ Open rollers.</li> <li>▶ Pitting/ rust.</li> </ul>
<b>Stitching</b>	<ul style="list-style-type: none"> <li>▶ Broken, cut or worn threads.</li> <li>▶ Damage or weakening of threads due to contact with heat, corrosives, solvents or mildew.</li> </ul>

## Lanyards and Energy Absorbers



There should be a minimum of slack in the fall-arrest lanyard between you and the anchor point, which should be as high as the equipment permits.

The length of the lanyard should restrict the fall distance to a maximum of 2 metres before the fall-arrest system takes effect.

Avoid work above the anchor point, as this will increase the free fall distance in the event of a fall, resulting in higher forces on the body and greater likelihood of the lanyard snagging on obstructions.

To reduce injuries caused by a fall, energy absorbers should be used as part of the lanyard.

Energy (or shock) absorber must be attached to the users rear dorsal D-ring.

## Inertia Reels

Inertia reels provide a worker with a relatively free range of movement or extra reach compared to a lanyard, with the added safety feature of being able to lock in the event of a fall, arresting the descent of the worker.

Inertia reels should not be used in the following situations:

- ▶ While working on a sloped surface (e.g. a steeply pitched roof) or any other surface where a fall may not be a quick vertical one
- ▶ Locked as a constant support for a worker during normal work
- ▶ In conjunction with a lanyard
- ▶ Missing, illegible or unreadable tag

Inertia reels must comply with AS 1891.3 *Fall-arrest devices*.



Shown here are some examples of some things you need to check an inertia reel for:

Component	Condition/fault to be checked
<b>Rope (Fully extend rewind drum anchorages)</b>	<ul style="list-style-type: none"> <li>▶ Cuts.</li> <li>▶ Abrasions or fraying.</li> <li>▶ Stretching.</li> <li>▶ Damage due to contact with heat, corrosives, or solvents.</li> <li>▶ Excessive dirt or grease impregnation.</li> <li>▶ With rewind anchorages give a firm pull with the rope fully extended to check that the rope end is securely anchored to the drum.</li> </ul>
<b>Anchorage body</b>	<p><b>a) Mountain ring:</b></p> <ul style="list-style-type: none"> <li>▶ Physical damage or wear, especially at any pivot points.</li> <li>▶ Cracks, especially in corners.</li> <li>▶ Mounting security.</li> </ul> <p><b>b) Anchorages body proper:</b></p> <ul style="list-style-type: none"> <li>▶ Physical damage such as significant dents, distortion, or corrosion.</li> <li>▶ As far as possible but, without dismantling, check for the entry of foreign bodies such as small stones.</li> <li>▶ Loose or missing screws, nuts or similar objects (external check only).</li> <li>▶ Position of the clutch compression indicator button (fitted only to rewind drums with steel rope).</li> </ul>
<b>Locking mechanisms and rope guides</b>	<ul style="list-style-type: none"> <li>▶ Check externally visible rope guides for excessive wear or ridging.</li> <li>▶ Check that the rope-locking mechanism locks and holds securely when the rope is given a sharp tug.</li> <li>▶ Ensure that the rope runs freely through the anchorage with no tendency to stick or bind, and that on rewind drum anchorages the rope rewinds completely without loss of tension.</li> </ul>
<b>Hardware</b>	<ul style="list-style-type: none"> <li>▶ Examine the condition and locking action of any associated snap hooks or links.</li> </ul>

## Isolate Defective Equipment

If you identify any equipment that is defective, damaged or faulty you must not use it. The equipment needs to be isolated from use to stop anybody from accidentally using it and the defect needs to be reported to an authorised person.

Make sure you complete any isolation procedures as required.

This may include tagging or locking out equipment and completing fault reports or other documentation.

Faulty equipment may need to be labelled and rejected, destroyed or returned to the manufacturer for repair (depending on the type and severity of the fault).



## Setting Up for the Task

### Check Ground Suitability and Load Limits for Structures

Before setting up the scaffold or any other equipment you need to check the ground conditions to make sure the scaffolding tasks are conducted on a firm surface capable of supporting the structure or task in a safe manner.

You also need to determine if a larger or more suitable base is required for the scaffold and equipment erection.

The scaffold or equipment could become unstable during operation if the ground is rough, uneven or soft. Back-filled trenches may not have compacted completely and are dangerous to set up the equipment on.

Check to make sure there are no underground services running through the area where you plan to set up the plant.

The pressure of the equipment could cause damage to the underground services/ pipes/ cables.

Different ground conditions and soil types can have an effect on the stability of a scaffold construction. You will need to establish the suitability and capacity of the ground before setting up the scaffold.

If you are unsure, you should refer to a soil report from a competent person such as a Civil Engineer or a Geo- technician.

Different ground and soil types have different load bearing pressures depending on how firm or dense they are:

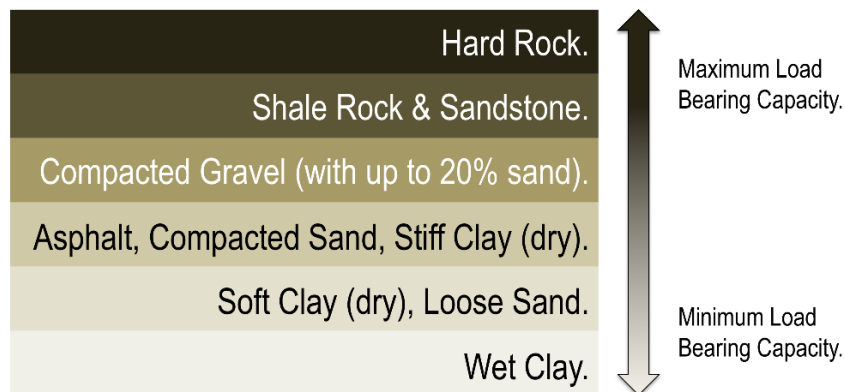

To make sure the ground is strong, firm and level enough to keep the scaffold erect, level (horizontally straight), plumb (vertically straight) and stable you need to know 2 things:

- ▶ The weight of the scaffold.
- ▶ The load bearing ability of the ground.

To work out the dead load weight of the scaffold, add the weight of all components resting on each baseplate.

Part	Weight	Part	Weight
Standards (2m)	12kg	Ladder Access Putlogs	8kg
Standards (3m)	18kg	Braces (3.6m)	17kg
Transoms	8kg	Ledger/ Guardrails	10kg
Braces (2m)	10kg	Ladders	20kg
Planks (1.2m)	10kg	Adjustable Baseplates	7kg
Planks (2.4m)	20kg		

### Dead Load

Adjustable Base Plate + Standard + ½  
ledgers+ ½ transoms + ½ braces + ¼ boards =  
kg's

### Live load

Duty ÷ 3 x no. of bays = kg's

### Length of Sole Board

Dead load + Live Load ÷ G.B.P ÷ 0.225 (min/  
width of sole board) = mm (in length of sole  
board)

(G.B.P = Ground Bearing Pressure, kg / m<sup>2</sup>)

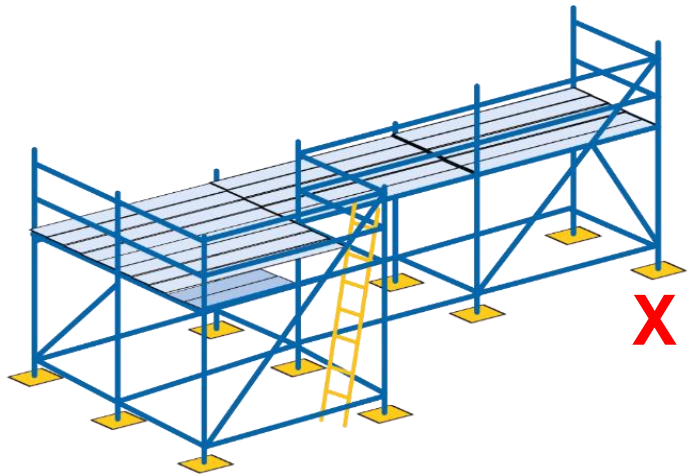

Using the information in the table we can

calculate that the total weight resting on the baseplate marked by the 'X' is 99.5kg.

## Fit Safety Equipment

All safety equipment needs to be fitted before starting the scaffolding work. You need to make sure it is appropriate for the task and that it fits you correctly.

Never begin a scaffolding task without the appropriate safety equipment.

Safety systems (such as static lines) and working at heights where there is a chance of falls, require the use of a full body fall-arrest harness and installed anchor points.

Safety equipment also includes Personal Protective Equipment (PPE). Always make sure you are wearing the correct PPE for the task and worksite.

Generally, as a minimum this would include:

- ▶ Hard hat/ safety helmet.
- ▶ Safety glasses.
- ▶ Safety gloves.
- ▶ Steel-capped work boots.
- ▶ High-visibility clothing.
- ▶ Fall arrest harness.
- ▶ Inertia reels, lanyards and shock absorbers.

Check for signage on site or talk to a manager or supervisor if you are unsure of the PPE requirements for the site.

## Prepare and Position Scaffolding Equipment

All equipment and scaffolding needs to be prepared in line with site procedures, the scaffolding plan and the manufacturer's specifications before you start the work.

Any equipment and plant that you will be using throughout the scaffolding work needs to be correctly and safely positioned. This could include positioning plant and equipment or moving scaffolding components into position where it can be safely accessed.

It also includes co-ordinating resources so that you have everything that you need in or close to the work area.

This will allow you to erect the scaffold and equipment without having to continuously leave the work area, or disrupt operations that may be taking place elsewhere on the worksite.

## Erecting Scaffold

Erecting a scaffold and scaffold equipment requires careful planning, knowledge of equipment and procedures, accurate site information and good communication skills.

Equipment should be unloaded as close as possible to the work area and arranged in a logical order.

All intermediate scaffold work must be conducted in accordance with legislative requirements including the following Australian Standards:

- ▶ AS 1576 – Scaffolding (tube & fitting).
- ▶ AS 1418.16 - Mast-climbers.

It is also important to consider site information before you start such as:

- ▶ Policies
- ▶ Structural plans and drawings
- ▶ Load bearings
- ▶ Job specifics
- ▶ Local Knowledge

You should already be familiar with this information by referring to it during the planning stages of the job, however things can change quickly on site and there may be new things to consider and manage.

Above all things you need to make sure that the site of the proposed scaffold is appropriate, safe, accessible and structurally capable of supporting the scaffold.

Make sure you consult with the appropriate site personnel (engineers, supervisors, other licensed scaffolders) before you start.



## Work Safely at Heights

Working at heights includes any situation where a worker, or other nearby person, is exposed to a risk of falling (from one level to another) that is likely to cause injury to the worker or person, or dropping of an object to another level below and causing injury or harm to others worker's or person's below.

Generally this includes:

- ▶ Work conducted in or on plant or a structure that is at an elevated level.
- ▶ Work conducted in or on plant that is being used to gain access to an elevated level.
- ▶ Work conducted near an opening through which a person could fall.
- ▶ Work conducted near an edge over which a person could fall.
- ▶ Work conducted on or near a surface through which a person could fall.
- ▶ Work conducted on or near a slippery, sloping or unstable surface.

Working at heights can be dangerous. Even with the use of safety equipment there is still a danger when working at heights.

All work at heights should include the use of safety equipment to prevent hazards such as personnel and materials falling from a height.

**DO NOT** ever work on the open framework of a scaffold without fall protection systems in place. Guardrails, mid-rails and toe boards should be installed on working platforms as soon as possible during the erection and dismantling of scaffolds.

To prevent internal falls, you must ensure that each platform is fully boarded out, and the planks should remain in place until the scaffold is dismantled.

The area below the work should be barricaded or fenced off to prevent unauthorised access by other workers or the general public. Where this is not possible, overhead protection decks such as temporary gantries, covered ways, cantilevered catch platforms, perimeter safety screens or debris/ safety nets may need to be installed.

Check access from the ground to the work area (where applicable) to make sure it is safe, free of obstructions and meets all safety and work requirements.

All hand tools should be attached to lanyards and securely stowed on a belt to maintain the safety of all personnel.

When working at heights:

- ▶ Make sure that the work area is kept clean and tidy. Rubbish should be removed regularly in a safe manner. Do not throw rubbish down from the work area to the ground.
- ▶ Keep access ways clear of materials, tools and equipment.
- ▶ Pass, receive and position components safely and confidently using the diagonal transfer method and twist and shout “mine”.
- ▶ When using hand lines, you should keep your back straight, your knees slightly bent, and your feet placed firmly on a ledger. Use the standard/ guardrails as an anchor for your body, if reaching through/ over guardrails, maintain 100% hook up.

## Scaffold Basic Level

### Erecting A Scaffold

An example of a typical scaffold erection could be:

1. Place two (2) screw jacks on the ground.
2. Place two (2) standards on the screw jacks.
3. Fix a transom to the lower parts of the standards at the required height.
4. Fix two (2) ledgers at the base of the standards, above and at 90 degrees to the transoms.
5. Place two (2) more standards on two (2) more screw jacks and fix to the other end of the ledgers.
6. Fix transoms to the lower parts of the standards at the required height.
7. Check that the structure is stable - adjust the level by using adjustable screws and wedges and square up the bay by measuring the diagonals.
8. Continue this process to create the required number of bays.
9. Place planks on the transoms to create a safe working surface to erect the next lift. Use a ladder for access.
10. Repeat steps 2-9 to create the second lift.
11. Install handrails, guardrails and toe boards.
12. Fix diagonal bracing.
13. Fix ties to the scaffold in the appropriate positions.



While erecting scaffold it is important to make sure that:

- ▶ Standards, transoms, ledgers, braces, platform brackets and tie bars are positioned and fixed correctly.
- ▶ Scaffold is squared, level and plumb.
- ▶ Toe boards, guardrails and mid rails are fixed.
- ▶ Ladder is positioned correctly and fixed.
- ▶ Scaffold matches the drawing or plans.

## Scaffold Intermediate Level

### Scaffold Task Requirements

It is important that you are familiar with the configurations and limitations of scaffolds, especially when considering different duty scaffolds, different materials (aluminium or steel) and methods of access. All of these factors will influence the design of the scaffold.

The following tables will help you to identify the limitations of different scaffolds and the allowable number of full-length working platforms (assuming that all but the base lift may potentially be used as a working platform).

Maximum number of full-length working platforms on light duty scaffold (access from base lift)				
Tube type	Scaffold height			
	8m	8m – 16m	16m – 24m	24m – 33m
Aluminium	4	N/A	N/A	N/A
Steel	4	3	N/A	N/A

Maximum number of full-length working platforms on light duty scaffold (access from building)				
Tube type	Scaffold height			
	8m	8m – 16m	16m – 24m	24m – 33m
Aluminium	4	4	3	3
Steel	4	7	6	6

Maximum number of full-length working platforms on medium duty scaffold (access from base lift)				
Tube type	Scaffold height			
	8m	8m – 16m	16m – 24m	24m – 33m
Aluminium	1	N/A	N/A	N/A
Steel	4	1	N/A	N/A

Maximum number of full-length working platforms on medium duty scaffold (access from building)				
Tube type	Scaffold height			
	8m	8m – 16m	16m – 24m	24m – 33m
Aluminium	3	2	2	2
Steel	4	5	5	4

Maximum number of full-length working platforms on heavy duty scaffold (access from base lift)				
Tube type	Scaffold height			
	8m	8m – 16m	16m – 24m	24m – 33m
Aluminium	N/A	N/A	N/A	N/A
Steel	4	N/A	N/A	N/A

Maximum number of full-length working platforms on heavy duty scaffold (access from building)				
Tube type	Scaffold height			
	8m	8m – 16m	16m – 24m	24m – 33m
Aluminium	2	2	2	2
Steel	4	4	3	3

### Scaffold Design Requirements

Scaffold design requirements:	
▶ Independent tube and coupler scaffold (max lift height of 2m).	<input type="checkbox"/>
▶ Scaffold is heavy duty (steel tube).	<input type="checkbox"/>
▶ Height of top lift is 8m.	<input type="checkbox"/>
▶ Length between end standards is 14.4m.	<input type="checkbox"/>
▶ Centre-to-centre transverse standard spacing 1.05m.	<input type="checkbox"/>
▶ Number of working platforms is 3 full-length working platforms.	<input type="checkbox"/>
▶ Location of platforms is on the upper 3 lifts.	<input type="checkbox"/>
▶ Safety screens must be used.	<input type="checkbox"/>
▶ Ladder access is required.	<input type="checkbox"/>
▶ Standards must be staggered.	<input type="checkbox"/>
▶ Platform planks are 225mm (wide) x 32mm (thick), Hardwood.	<input type="checkbox"/>
▶ Platform width is 4 planks between the standards.	<input type="checkbox"/>

### Available tube lengths (metres)

- ▶ 1.2      ▶ 1.5      ▶ 1.8      ▶ 2.1      ▶ 2.4      ▶ 2.7
- ▶ 3.0      ▶ 3.3      ▶ 3.6      ▶ 4.2      ▶ 4.5      ▶ 4.8
- ▶ 5.1      ▶ 5.4      ▶ 5.7      ▶ 6.0      ▶ 6.3

### Available plank lengths (metres)

- ▶ 1.2      ▶ 1.5      ▶ 1.8      ▶ 2.1      ▶ 2.4      ▶ 2.7
- ▶ 3.0      ▶ 3.3      ▶ 3.6      ▶ 3.9      ▶ 4.2

## Scaffold Erection Requirements

Scaffold erection requirements:	
▶ Edge protection is guardrails, mid-rails and toe-boards on outside and ends of platforms.	<input type="checkbox"/>
▶ Longitudinal bracing will be fixed to each outside panel in the end bays and in one intermediate bay.	<input type="checkbox"/>
▶ Ledgers will be fixed to the inside of the standards.	<input type="checkbox"/>
▶ The first lift will be fixed with transoms set below the ledgers.	<input type="checkbox"/>
▶ The working lifts will be fixed with putlogs and putlog couplers.	<input type="checkbox"/>
▶ Putlogs are required on non-working platforms to carry planks for erection purposes.	<input type="checkbox"/>
▶ Guardrails are required on non-working platforms.	<input type="checkbox"/>
▶ Working lifts fixed with putlog couplers require transoms set below ledgers.	<input type="checkbox"/>
▶ Non-working lifts require transoms or putlogs fixed with right-angle couplers.	<input type="checkbox"/>
▶ Braces will be fixed to the standards with swivel couplers.	<input type="checkbox"/>
▶ Guard rails and mid rails will be fixed to the standards with right angle couplers.	<input type="checkbox"/>
▶ All joints will be fixed with sleeve-type end-to-end couplers.	<input type="checkbox"/>
▶ Handballing is only feasible up to the second lift. A gin wheel or materials hoist may be required for the erection of the higher lifts.	<input type="checkbox"/>

## Relevant site information

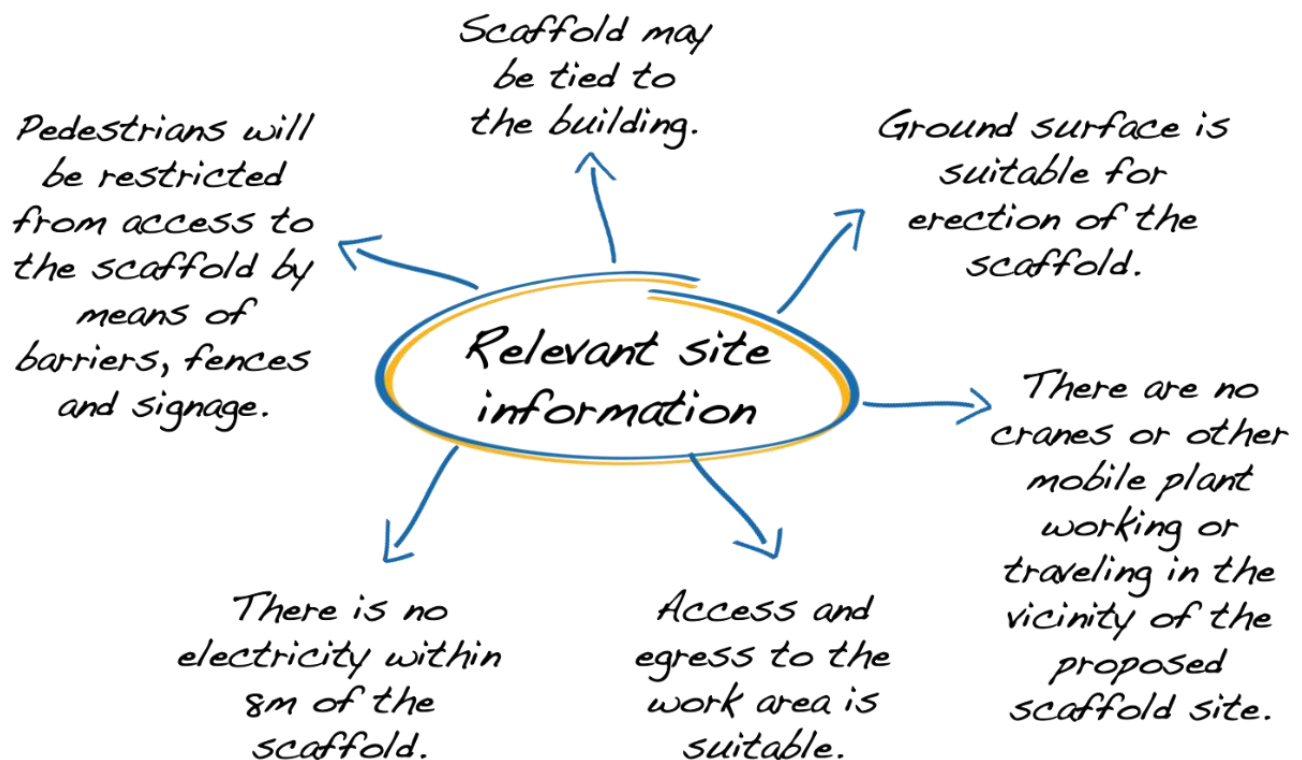

## Scaffold Drawings

The drawing/design will help you to work out what parts you will need. Shown here is a drawing of the scaffold that would be used to meet these design and erection requirements:

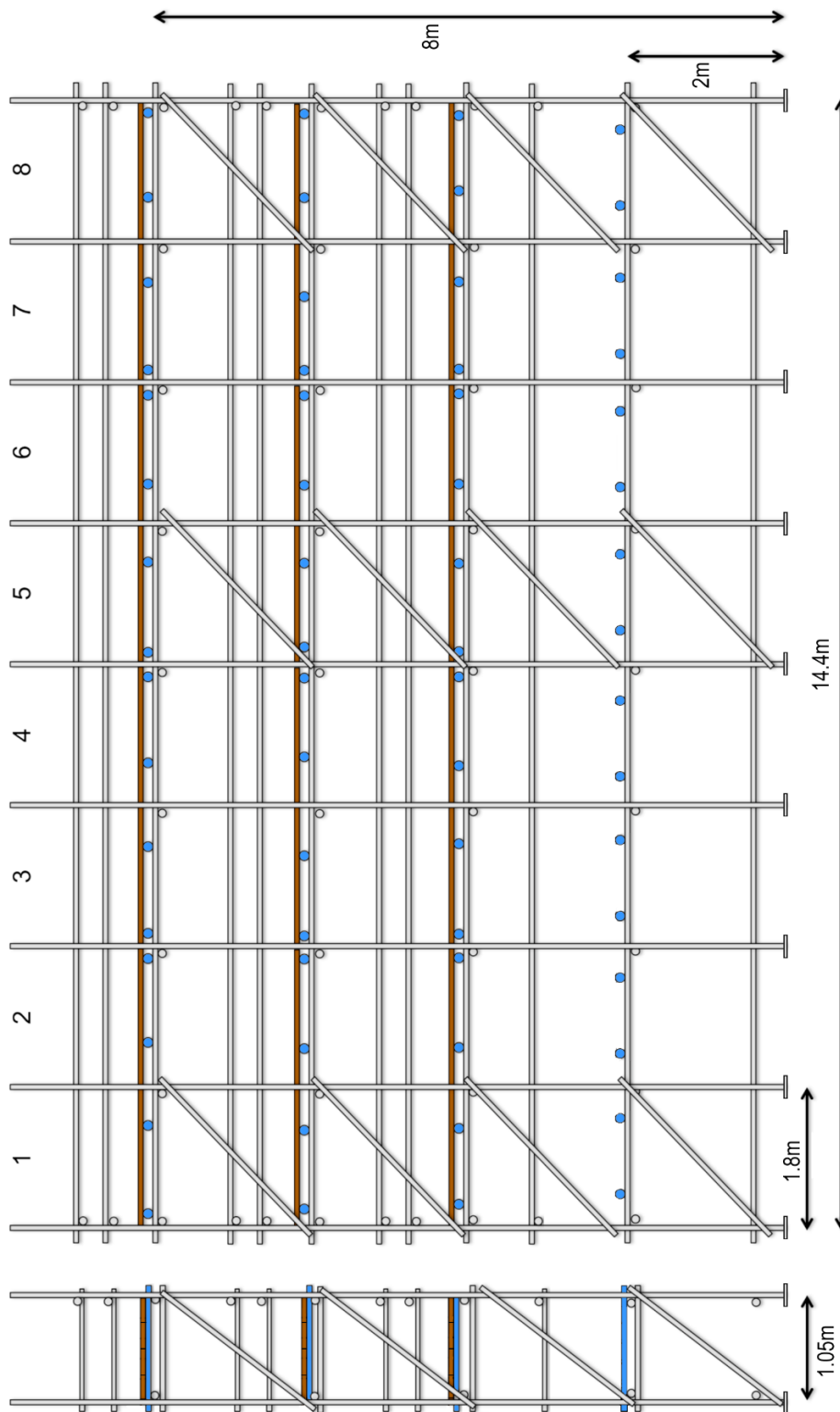

*Note: Putlogs marked in blue. Ladders, toeboards and screens have been omitted for clarity.*

Standards and ledgers need to be properly spaced and joined to maintain the stability of the scaffold. Shown here is an example of how the tubes could be joined (using the tube lengths provided):

1.5m	2.1m	3.6m	4.2m	5.4m	6.3m
------	------	------	------	------	------

It is important that your drawings make note of the tie in points on the scaffold:

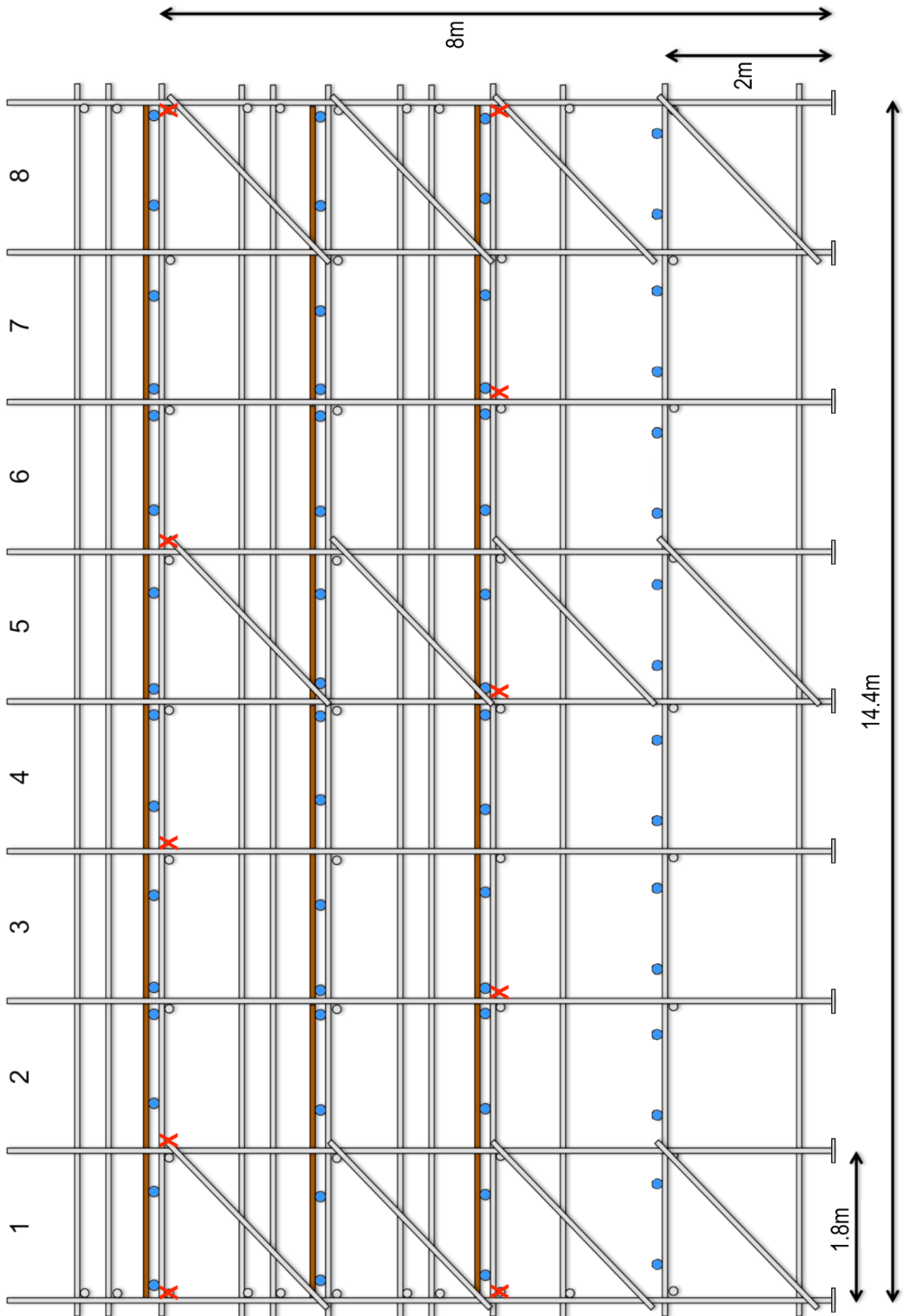

You may also need to mark where swivel clips/couplers are being used:

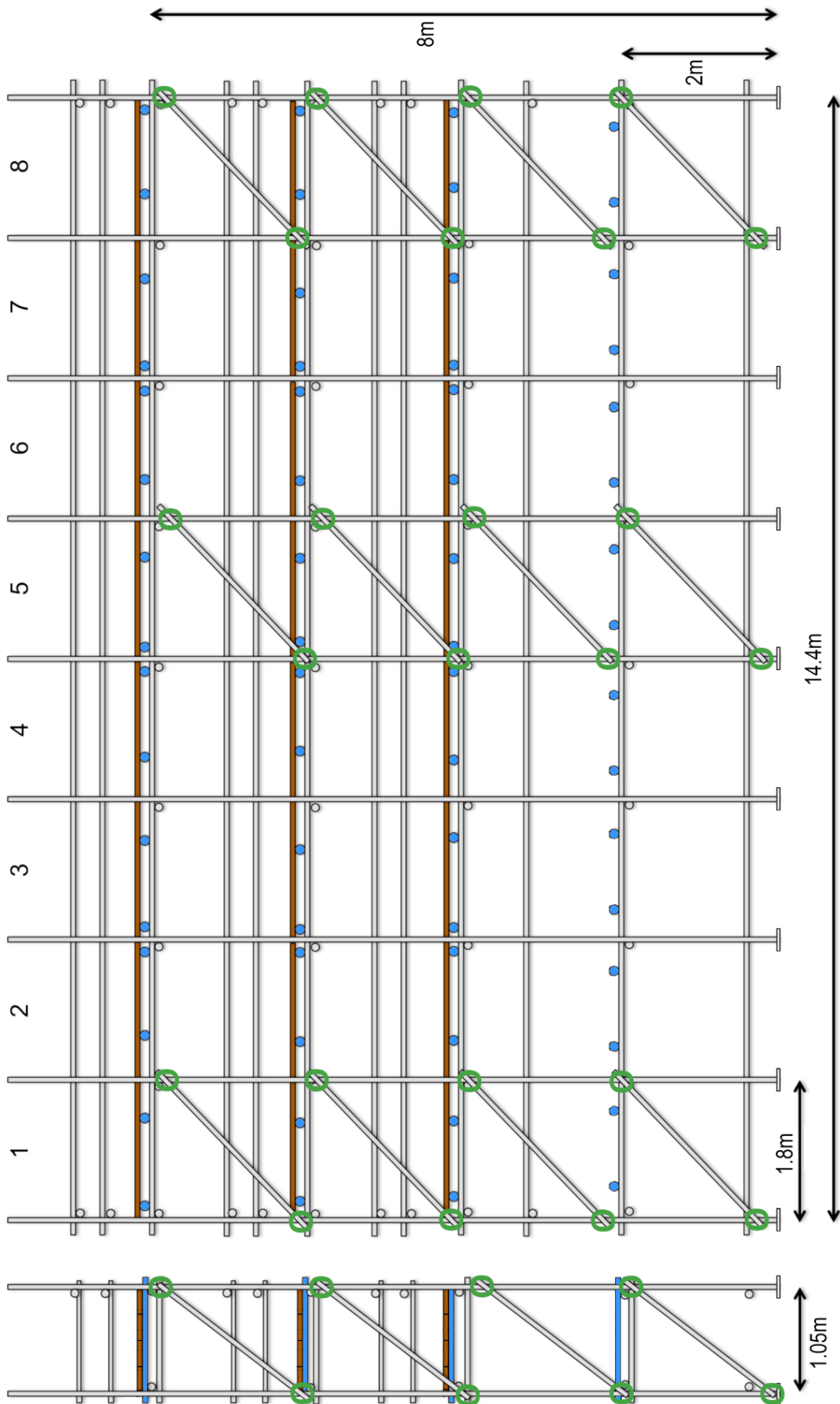

This drawing, combined with the site and job information provided will allow you to work out what parts and equipment you will need, and the quantities of each item to erect the scaffold properly.

The table below lists the parts required for this particular scaffold:

Part	QTY Required	Usage Notes
1.2m Scaffold tube	114	Used for transoms and putlogs.
1.5m Scaffold tube	6	Used for standards.
2.1m Scaffold tube	35	Used for standards and ledgers.
2.4m Scaffold tube	8	Used for transverse bracing.
2.7m Scaffold tube	12	Used for longitudinal bracing.
3.6m Scaffold tube	46	Used for standards and ledgers.
4.2m Scaffold tube	12	Used for standards.
5.4m Scaffold tube	17	Used for ledgers.
6.3m Scaffold tube	6	Used for standards.
2.7m Hardwood plank	6	Used for ladder access to working platforms.
3.6m Hardwood plank	42	Used for working platforms.
Right angle/fixed coupler	285	Used to secure transoms, ledger, putlogs (on non-working platforms), ties, guardrails and midrails.
Swivel coupler	40	Used to secure bracing.
Putlog coupler	96	Used to secure putlogs on working platforms.
Sleeve type end to end joiners	87	Used to join standards and ledgers.
Baseplates	18	Adjustable baseplates may be required depending on surface condition and grade.

*Note: Additional components will be required depending on tie in methods used, and for edge protection around ladder access. Tie tubes must not be joined so adequate length tubes (or extended transoms) must be selected (depending on the configuration of the ties).*

## Erecting A Tube and Fitting Scaffold

An example of a typical scaffold erection could be:

1. Ensure surface/ground conditions are adequate.
2. Place sole boards on ground/deck.
3. Place base plates on sole boards.
4. Place two (2) standards on base plates.
5. On transverse parts of the scaffold.
6. Fix a transom to the lower parts of the standards at the required height.
7. Fix two (2) ledgers at the base of the standards, both above and at 90 degrees to the transoms, and fix to the other end of the ledgers to the standards.
8. Fix a transom to the lower parts of the standards at the required height underneath the ledger.

9. Fix diagonal bracing (bracing used to level/plumb standards).
10. Check that the structure is stable – adjust, level and square up the bay by measuring the diagonals.
11. Continue this process to create the required number of bays.
12. Place planks on the transoms to create a safe working surface to erect the next lift. Use a ladder for access.
13. Repeat steps 2-9 to create the second lift.
14. Install handrails, guardrails and toe boards.
15. Fix ties to the scaffold in the appropriate positions.

While erecting scaffold it is important to make sure that:

- ▶ Standards, transoms, ledgers, braces, and ties are positioned and fixed correctly.
- ▶ Scaffold is squared, level and plumb.
- ▶ Toe boards, guardrails and mid rails are fixed.
- ▶ Ladder is positioned correctly and fixed.
- ▶ Scaffold matches the drawing or plans.

If you are working with a crane- lifted scaffold, ensure that the working deck planks are secure before it is moved. They can be secured by lashing, strapping or spiking them.

If an uncompleted scaffold must be left overnight, you must remove all access to the scaffold and isolate or barricade off the area.

Use signage and physical barriers to prevent unauthorised access to the scaffold.

## Tube and Fitting Scaffold Requirements

Tube and coupler scaffold requirements:	
Make sure the scaffold is not higher than 33m.	<input type="checkbox"/>
Make sure you do not make the bay lengths too wide or too long for the duty of the scaffold. The bay of a single-pole scaffold should be no more than 1.8 metres long.	<input type="checkbox"/>
The lift height of an independent scaffold should be no more than 2 metres (3 metres if double standards are used).	<input type="checkbox"/>
Make sure you measure the correct positions on scaffold tubes where couplers are to be placed. Mark clearly where the couplers are to be placed showing which side of the line they are to be aligned.	<input type="checkbox"/>
Make sure couplers are square and placed the right way up. Always use compatible couplers in the same lift.	<input type="checkbox"/>
Make sure all transoms, ledgers, guardrails, midrails and braces are fixed firmly and in their correct positions.	<input type="checkbox"/>
If braces need to be joined use a lapping or splicing technique.	<input type="checkbox"/>
Toeboards should be fixed to standards with a gap of no more than 10mm. Where equipment or materials are stacked to a height that is above the height of the toeboard a guardrail, toeboard and infill panel are required for edge protection.	<input type="checkbox"/>
Make sure a tube and coupler scaffold does not carry too many platforms. For example, a 33m high medium duty scaffold can carry four full length platforms if made of steel tubes but only two if made of aluminium tubes. A 20m high steel tube scaffold should have no more than 5 platforms.	<input type="checkbox"/>

## Platform Requirements

Platform planks should all be the same thickness. They should be lashed securely using a spliced eye or clove hitch with half hitches around the putlogs. Planks may be lapped at the returns of the scaffold, or to match irregular building profiles.

The slope of a platform should be at an angle of no more than 7 degrees in all directions (AS/NZS 4576:1995-8.7).

Platform planks should be placed close together and overhang putlogs no less than 150mm and no more than 250mm.

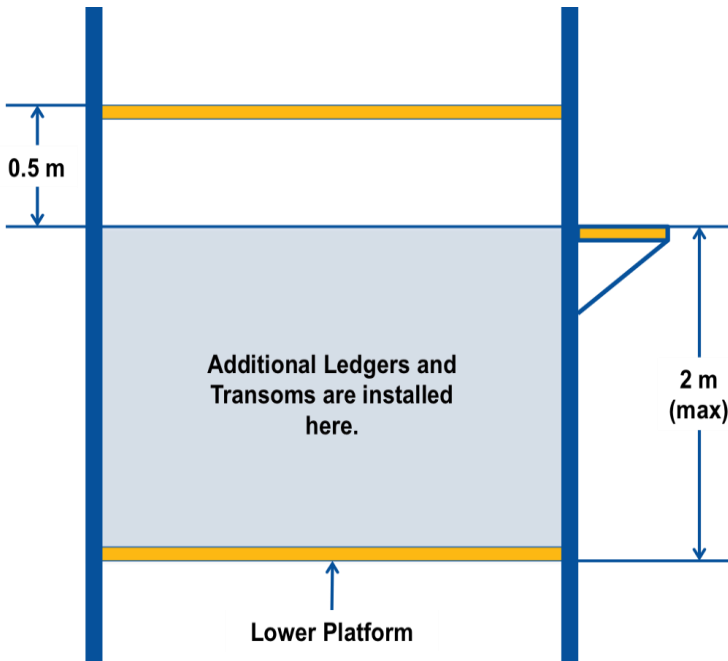

Where bay widths are not fully covered by the planks (e.g. on a birdcage type scaffold) you may use a structural plywood as an underlay to the platform planks where gaps are up to 150mm wide.



## Erecting A Spurred Scaffold

Raker scaffolds may be used where the conditions make it unfeasible to erect a cantilevered scaffold, or a scaffold that is erected from the ground.

Standard is being supported by raker tubes in tension.

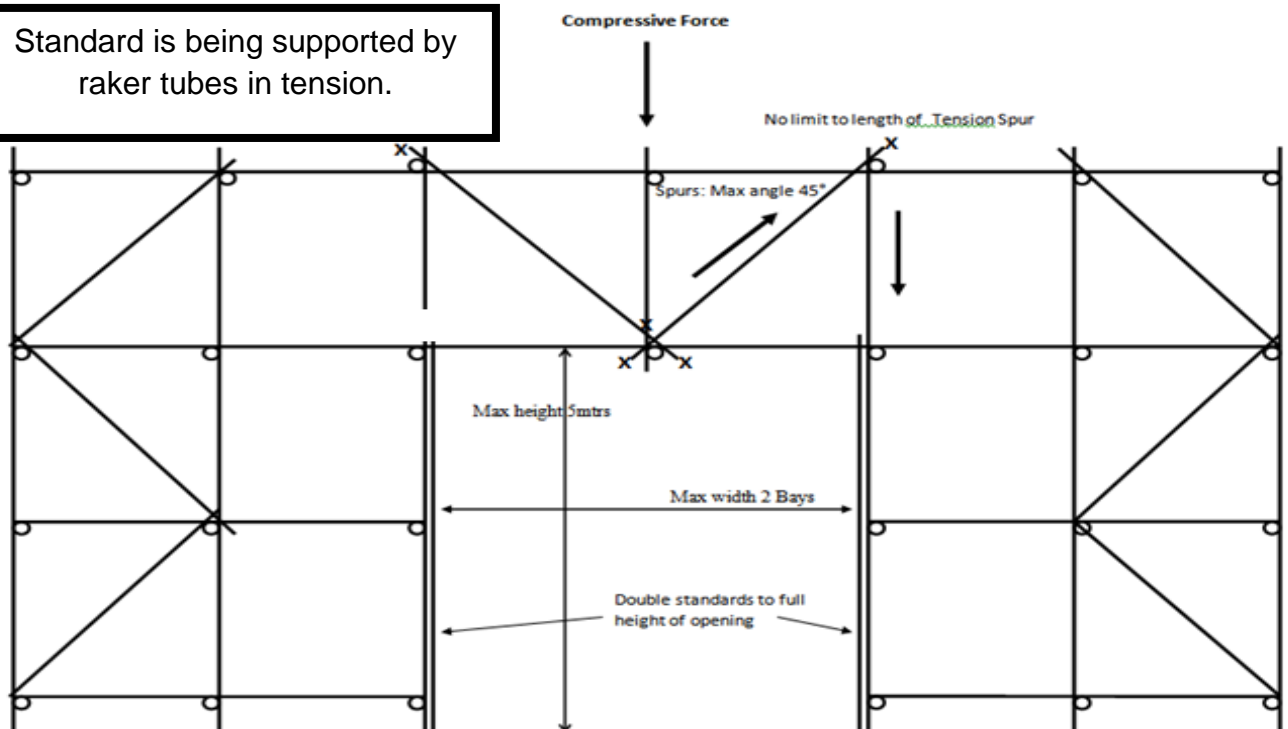

When erecting a spurred scaffold:

- ▶ A single set of spurs can support up to five lifts.
- ▶ A compression spur should be no more than 2 metres long between node points.
- ▶ Use a right-angle coupler to fix a spur to a scaffold framework.
- ▶ A spur should be fixed at an angle of no more than 45 degrees from the vertical.

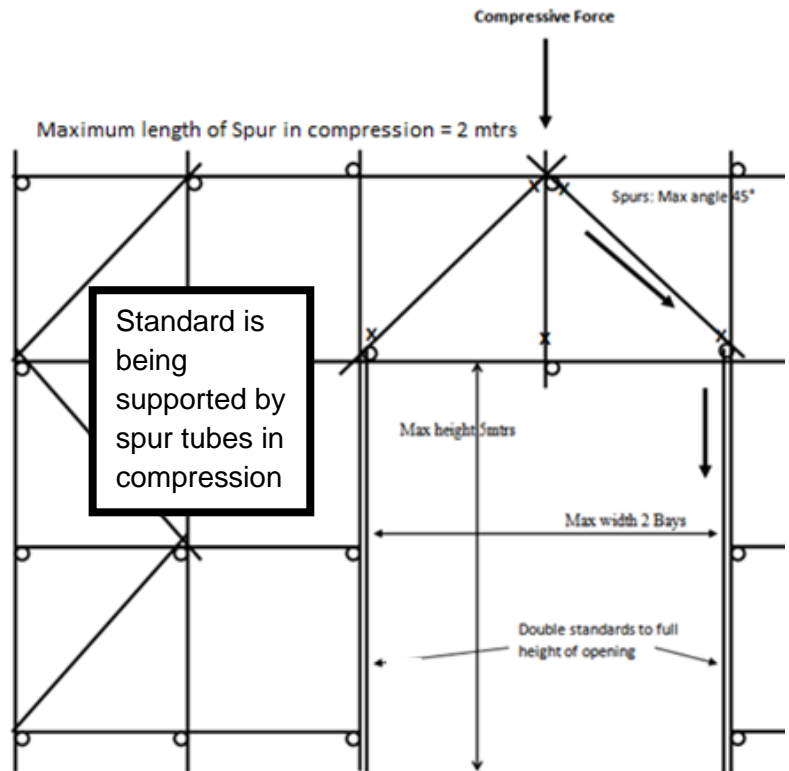

Before a spurred scaffold can be used, it must be inspected by a competent person such as an engineer with experience in scaffolding structural design and analysis, as well as knowledge of the relevant Australian Standards.

### Erecting A Barrow Ramp or Sloping Platform

Barrow ramps and sloping scaffolds are designed to allow you to safely and easily access low level working platforms with wheeled equipment (such as a wheelbarrow).



All barrow ramps and sloping scaffolds must conform to the following standards:	
▶ As with all scaffold working platforms the transverse slope must not exceed 3 degrees. The longitudinal slope should be at an angle of no more than 20 degrees on a cleated barrow run. Any slope greater than 7 degrees will require slip restraint (cleats).	<input type="checkbox"/>
▶ The cleats should be 450 mm apart with a 100 mm gap between them for the wheel of a barrow.	<input type="checkbox"/>
▶ The lower ends of sloping ledgers should be placed on soleplates.	<input type="checkbox"/>
▶ Sloping guardrails and midrails should be fixed to standards with swivel couplers so that they match the slope of the platform (providing the best possible protection).	<input type="checkbox"/>
▶ Cleats and lashing are both acceptable methods of preventing 'plank creep' on a sloping platform. Cleats may be fixed to the underside of the plank hard against the putlog, or the planks may be lashed directly to the putlog.	<input type="checkbox"/>

## Scaffold Advanced Level

### Erecting A Hung (Tube and Fitting) Scaffold

An example of a typical scaffold erection could be:

1. Install beam clamps (used in pairs) to the rated structure.
2. Install tubes into beam clamps.
3. Make up droppers/hangers with butt tube (perches) and check fittings installed both above the supporting fitting and below the perch.
4. Install four (4) droppers/hangers from the head frame, and box them out at the top with tube and fitting.
5. Fix diagonal bracing to plumb/level standards using swivel couplers.
6. Fix a transom to the lower parts of the standards at the required height.
7. Fix two (2) ledgers at the base of the standards, both above and at 90 degrees to the transoms, and fix to the other end of the ledgers to the standards.
8. Fix a transom to the lower parts of the standards at the required height underneath the ledger.
9. Check that the structure is stable – adjust, level and square up the bay by measuring the diagonals.
10. Continue this process to create the required number of bays.
11. Place planks on the transoms to create a safe working surface to erect the next lift. Use a ladder for access.
12. Repeat steps 2-9 to create the second lift.
13. Install handrails, guardrails and toe boards.
- 14.
15. Fix ties to the scaffold in the appropriate positions.

While erecting scaffold it is important to make sure that:

- ▶ Standards, transoms, ledgers, braces, and ties are positioned and fixed correctly.
- ▶ Scaffold is squared, level and plumb.
- ▶ Toe boards, guardrails and mid rails are fixed.
- ▶ Ladder is positioned correctly and fixed.
- ▶ Scaffold matches the drawing or plans.

If you are working with a crane- lifted scaffold, ensure that the working deck planks are secure before it is moved. They can be secured by lashing, strapping or spiking them.

If an uncompleted scaffold must be left overnight, you must remove all access to the scaffold and isolate or barricade off the area.

Use signage and physical barriers to prevent unauthorised access to the scaffold.

### Hung Scaffolds

Hung scaffolds come in 2 main types:

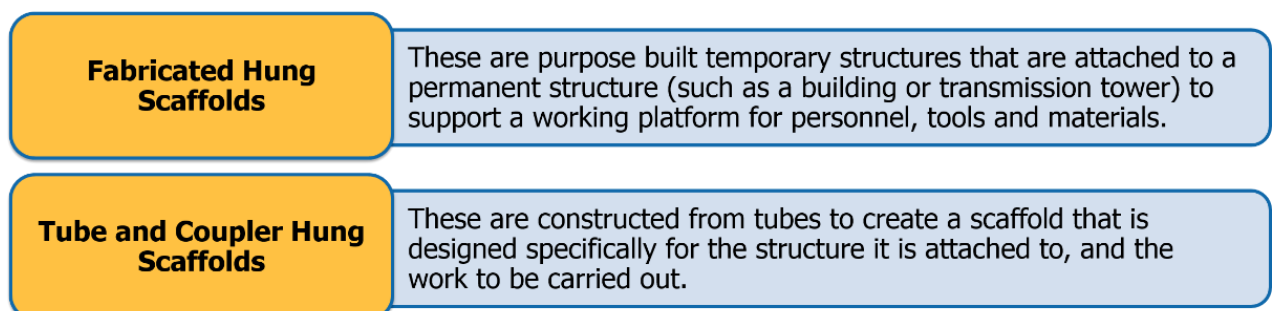

Hung scaffolds are usually positioned in a static location, but depending on the work being conducted, may be hung from girder trolleys or mobile suspension rigs so they have limited horizontal (sideways) movement. Hung scaffolds are not capable of being raised or lowered while in use.

Shown here is an example of a hung scaffold that is supported by steel beams. The supports shown in the example are tubes, however it is possible for a hung scaffold to be supported using beam clamps and chains or FSWR.

Hung scaffolds may also be erected with supports that pass through a supporting structure such as a grating or suspended concrete floor.

When erecting a hung scaffold **DO NOT**:

- ▶ Use open-ended hook rods.
- ▶ Extend its length by fixing scaffold tubes with end-to-end couplers.

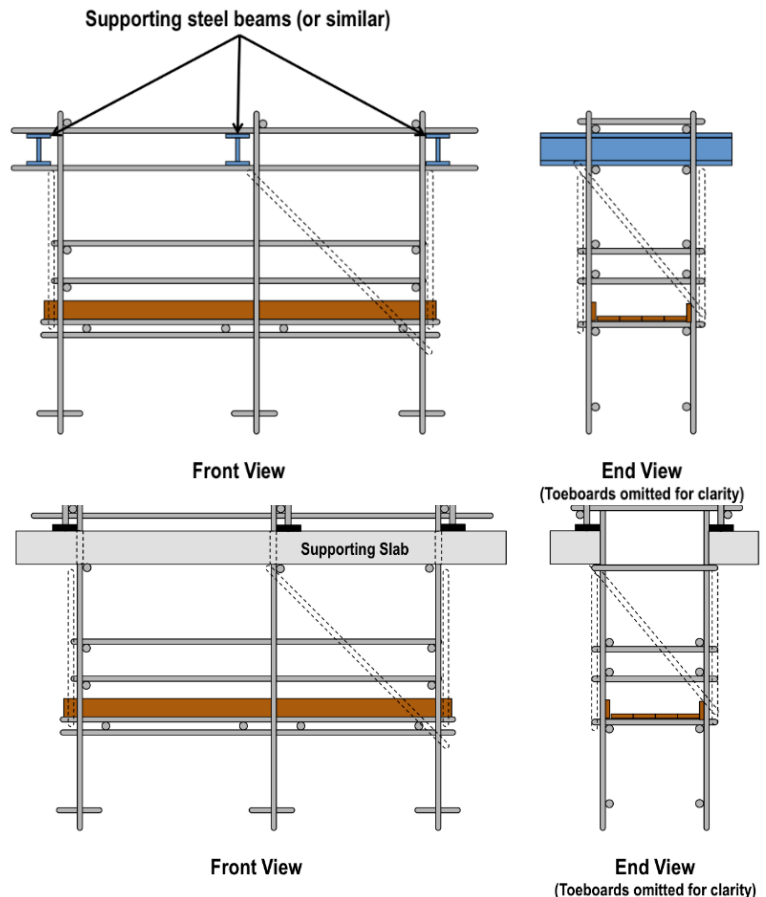

The building or structure to which a hung scaffold is to be mounted must be able to support the scaffold as well as all loads placed upon it (e.g. dead loads, live loads, wind loads). The supporting structure should be assessed by a competent person before the hung scaffold is erected, such as an engineer.

**This may also be a Structural Engineer with experience in scaffolding structural design/ analysis and knowledge of the relevant Australian Standards (such as AS/ NZS 1576).**

You must also check the load bearing limits of suspended concrete floors, building roofs, structures and landings if any loads, scaffolds or equipment is going to be resting on them.

Structural changes made to the hung scaffold should be recorded on a design plan and reviewed by a competent person.

## Hung Scaffold Requirements

All hung scaffolds must meet some basic safety and construction requirements. The following table outlines the minimum requirements for hung scaffolds:

Item	Requirements
Platform	<ul style="list-style-type: none"> <li>▶ The platform of a hung scaffold should be evenly decked, slip resistant and free from trip hazards. It should be secured safely to prevent movement.</li> <li>▶ Generally, the platform should be horizontal with an allowable slope of 3° in all directions, although sloping platforms may be designed for certain purposes. The slope of a working platform should be no more than 7° (1:8 if engineered designed and approved).</li> </ul>
Edge Protection	<ul style="list-style-type: none"> <li>▶ Required where a person could fall more than 2m.</li> <li>▶ Scaffold tube, purpose designed component or hardwood may be used for a guardrail. Fibre rope, flexible steel wire rope (FSWR) and chain must never be used as a guardrail.</li> </ul>

Item	Requirements
	<ul style="list-style-type: none"> <li>▶ Guardrail should be positioned between 900mm and 1100mm from the work platform surface.</li> <li>▶ Toe boards must extend at least 150mm above the surface of the working platform.</li> <li>▶ Mid-rails, infill, brick guards or mesh must be positioned between the toe board and the guardrail.</li> </ul>
Access	<ul style="list-style-type: none"> <li>▶ Single industrial grade ladders may be used to access working platforms. Domestic grade or extension ladders must not be used.</li> <li>▶ Ladder access should be fixed in a position between 6:1 max and 4:1 min vertical to horizontal.</li> <li>▶ The minimum height that a portable access ladder must extend above the landing is 900mm.</li> <li>▶ Access ramps may have a slope of up to 20° (1:3) as long as they are cleated to prevent slip hazards. Cleats should be 50 mm wide and 25mm thick and fixed at intervals of 450mm.</li> </ul>
Supports	<ul style="list-style-type: none"> <li>▶ A hung scaffold can be fixed to a supporting structure in several ways including rigid supports or slings (chain and FSWR) and shackles.</li> <li>▶ Trolleys, beam clamps and shackles used to support a hung scaffold should have a rated capacity of at least 500 kg.</li> <li>▶ Flexible Steel Wire Rope (FSWR) must have a minimum construction of 6x24 and be at least 11 mm in diameter when used to support a hung scaffold.</li> <li>▶ Chain must be at least Grade T and not less than 8mm in diameter when used to support a hung scaffold.</li> <li>▶ The maximum load placed on FSWR or chain must not be more than 1/6 of its minimum breaking strain.</li> <li>▶ The Rated Capacity of FSWR can be estimated using the formula: <ul style="list-style-type: none"> <li>◆ Diameter squared x 7.5 e.g. 11mm x 11mm x 7.5 = 907.5kg</li> </ul> </li> <li>▶ Beam chaffers, half rounds and split tubes can be used to protect a Flexible Steel Wire Rope (FSWR) from damage when it is placed around the sharp edges of a beam.</li> <li>▶ Shackle pins should be moused to stop them from unwinding.</li> <li>▶ Do not use speed thread or multi-start thread coupler bolts for fixing hung standards.</li> <li>▶ Couplers should be fixed on a ledger on either side of the eye of a sling to stop it sliding.</li> </ul>
Positioning	<ul style="list-style-type: none"> <li>▶ Trolleys should have a rated capacity greater than the total load they are to support.</li> <li>▶ Rigid tie bars and plan bracing may be used to prevent girder trolleys from moving out of alignment. This will help the standards to remain vertical.</li> <li>▶ Girders are required to have through-bolted stops to prevent the trolley from overrunning or running off the end of the girder.</li> </ul>

### Examples of Hung Scaffolding using FSWR & Chains

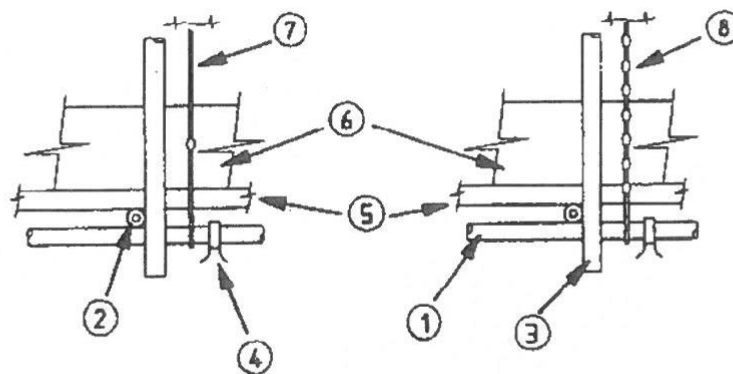
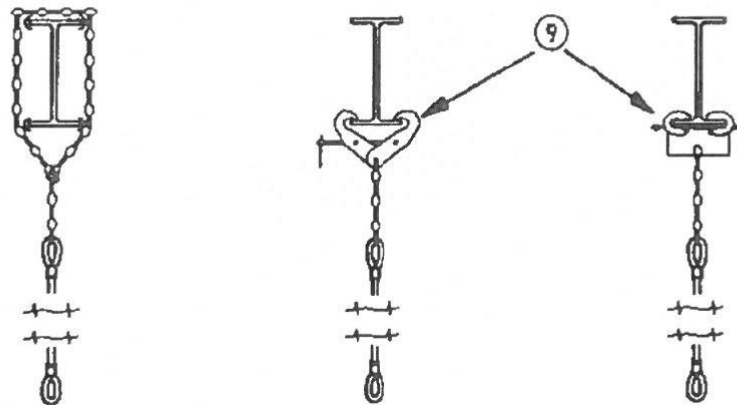
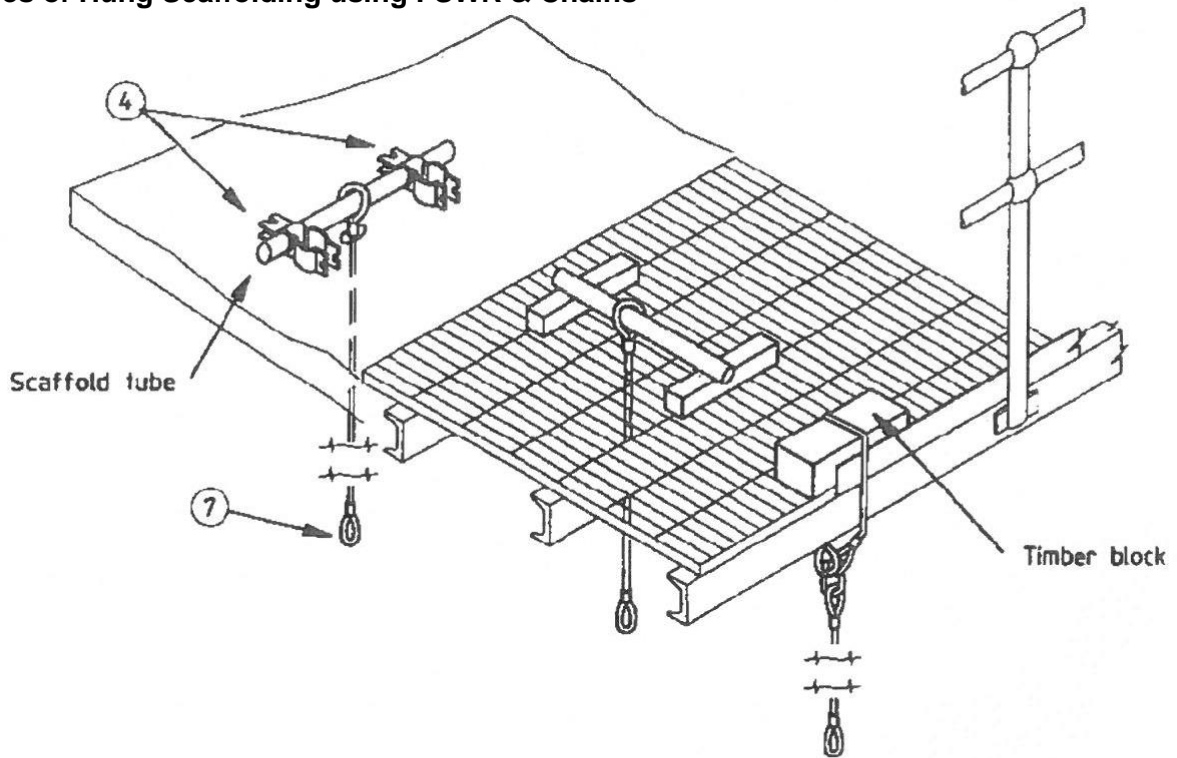

**LEGEND:**

- 1 Ledger
- 2 Putlog
- 3 Guardrail stanchion
- 4 Keeper clip
- 5 Platform plank
- 6 Toeboard
- 7 FSWR sling with soft eye
- 8 Short-link chain with lifting ring
- 9 Beam clamp

## Examples of Hung Scaffolds (Tube & Fitting)

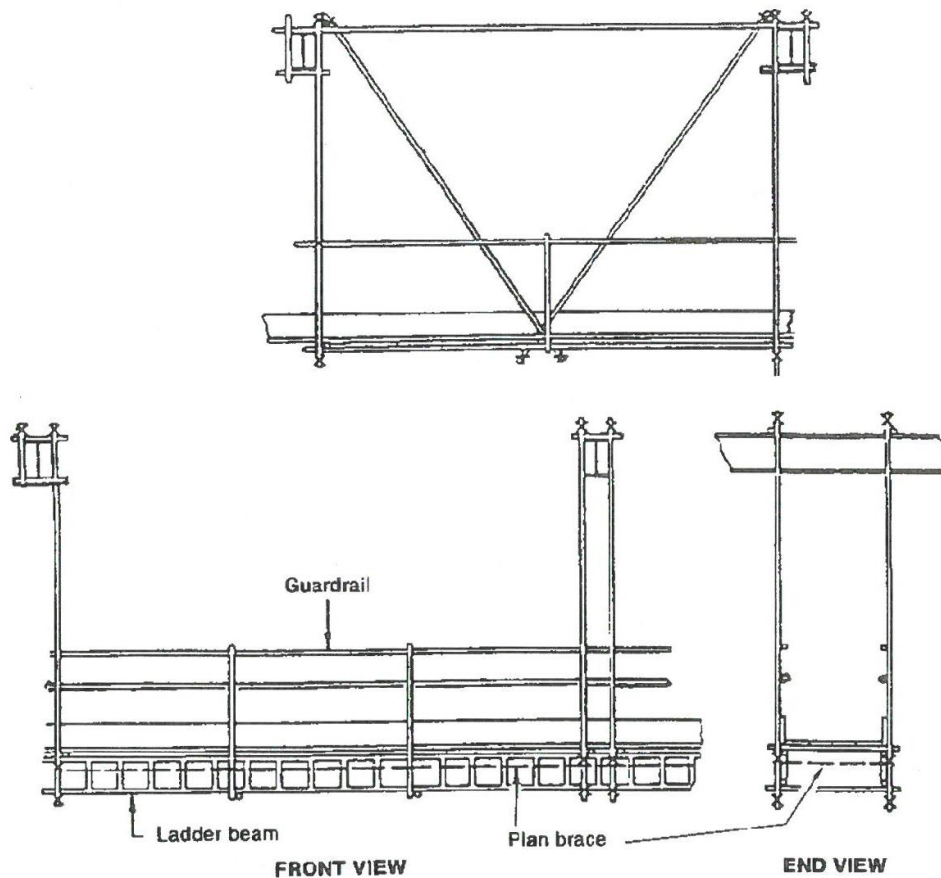

## Suspended Scaffolds

A suspended scaffold has a platform that is supported by temporary supporting structures, and can be raised and lowered using flexible steel wire rope hoists. These are often associated with window washers.

Suspended scaffolds include:

- ▶ Swing stages
- ▶ Double rope suspended platforms
- ▶ Work cages
- ▶ Boatswains chairs

Suspended scaffolds may be used for short term work on the sides of tall buildings or structures where access by other means is limited by the height of the work being carried out.

Where access to the scaffold is not from the ground, or a protected landing, a safety harness and lanyard attached to a fall protection system/**suitable anchorage (rated to 15kN for a single person free fall and 21kN for no more than 2 people)** must be used to access the scaffold cradle/platform safely.

The building or structure to which the suspended scaffold is to be mounted must be able to support the scaffold as well as all loads placed upon it (e.g. dead loads, live loads, wind loads).

The supporting structure should be assessed by a competent person such as an engineer with experience in scaffolding structural design/analysis and knowledge of the relevant Australian Standards, before the suspended scaffold is erected. He will provide you with plans and load bearing capacities.

Others that should be consulted could include, but are not limited to:

- ▶ Safety Officer
  - ◆ Site specific hazards and controls
  - ◆ Workplace policies and procedures
- ▶ Supervisor
  - ◆ Job specifics
  - ◆ Workplace knowledge

All suspended scaffolds and suspension rigs must meet the relevant compliance requirements including:

- Engineering specifications.
- Manufacturer's specifications.
- AS1576.4 Suspended scaffolding.

These compliance requirements are relevant when erecting or altering an existing scaffold.

### Swing Stages

A swing stage provides a suspended work platform for multiple personnel that can be raised and lowered using manual, pneumatic or electric hoists. A swing stage may be made up of the following components:

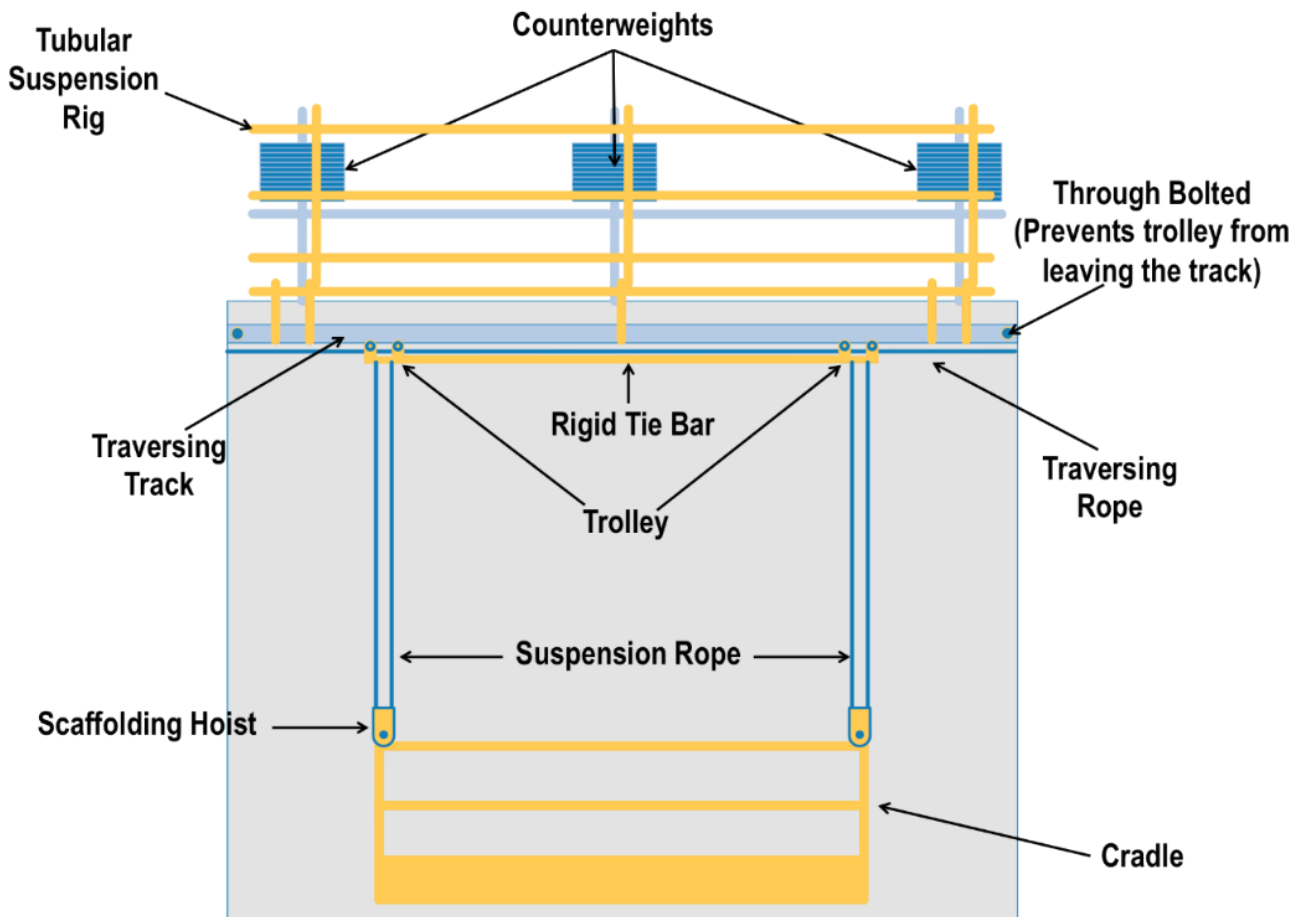

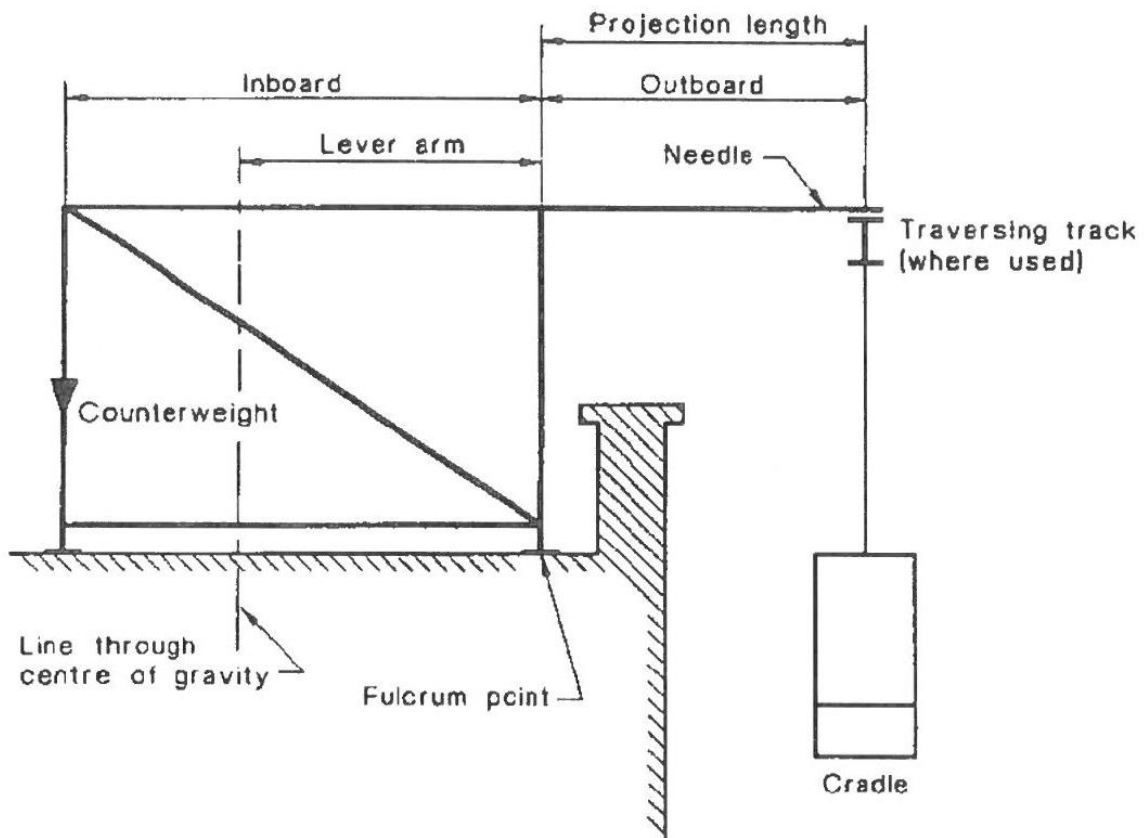
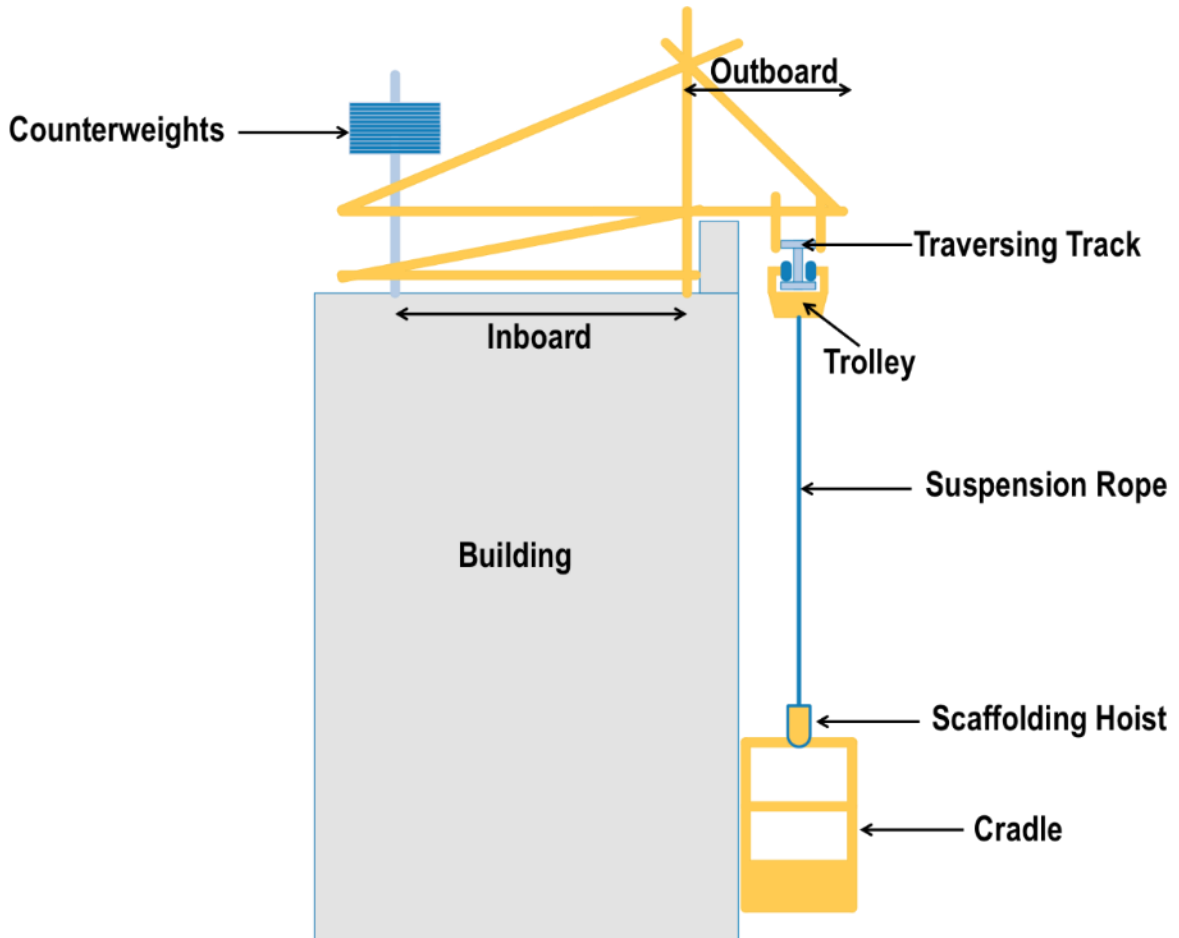

## Traversing Swing Stage Arrangement

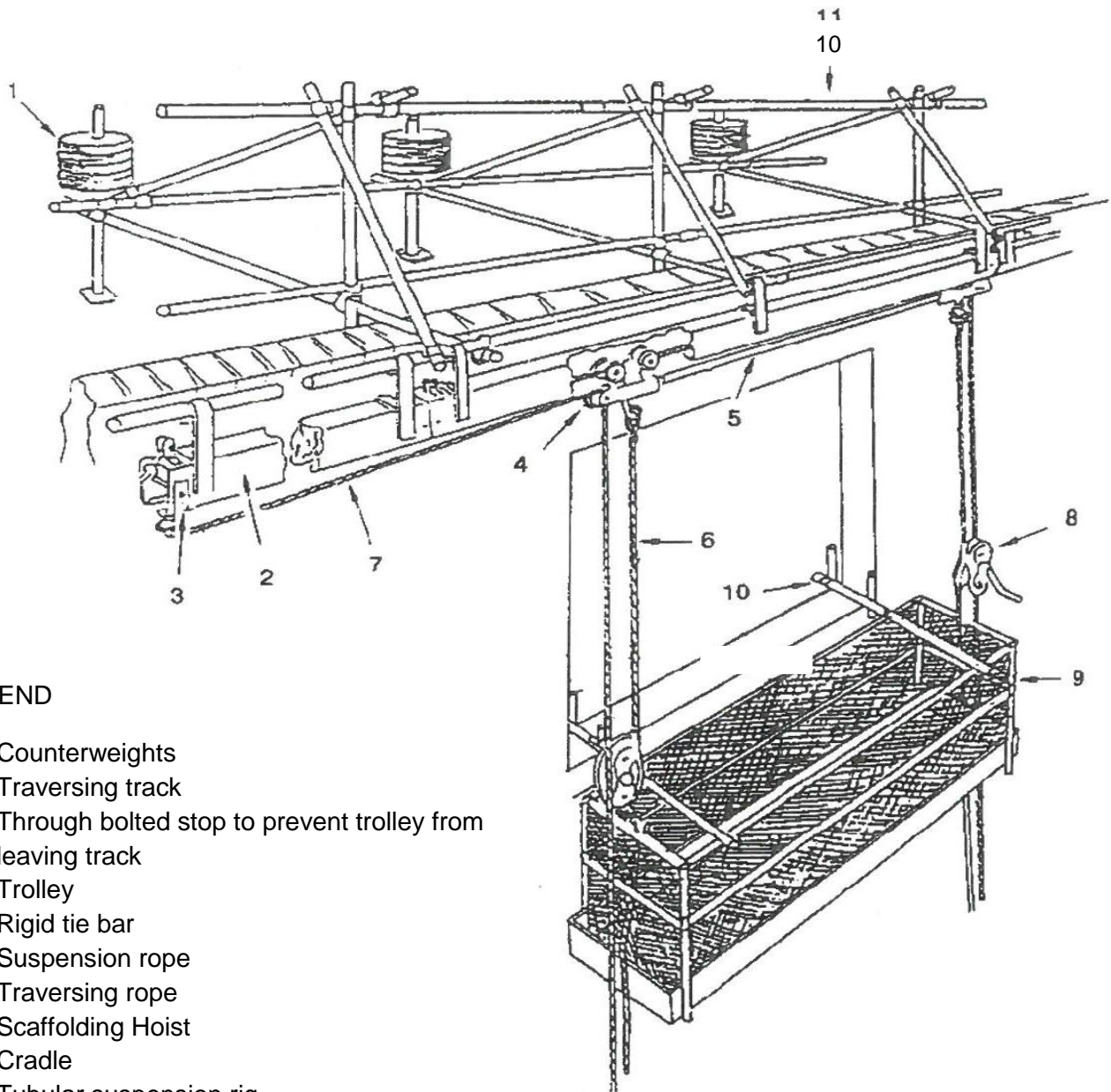

### LEGEND

1. Counterweights
2. Traversing track
3. Through bolted stop to prevent trolley from leaving track
4. Trolley
5. Rigid tie bar
6. Suspension rope
7. Traversing rope
8. Scaffolding Hoist
9. Cradle
10. Tubular suspension rig

### Cradle

All scaffold cradles must meet some basic safety and construction requirements. The cradle width requirements for different scaffolds are:

Scaffold Type	Minimum Cradle Width	Maximum Cradle Width
Double Rope Suspended Scaffold	900mm	1.7m
Swing Stage	450mm	900mm
Suspended Work Cage	750mm	1.5m

Other requirements include:

Item	Requirements
Cradle	<ul style="list-style-type: none"> <li>▶ Should be fitted with:               <ul style="list-style-type: none"> <li>◊ Guardrails.</li> <li>◊ Mid-rails.</li> <li>◊ Toe-boards.</li> </ul> </li> <li>▶ Working deck safely secured to prevent movement.</li> <li>▶ Slip resistant with adequate drainage holes.</li> <li>▶ Free from trip hazards.</li> <li>▶ Up to a 3°-degree slope in all directions is allowable in the scaffold platform, unless otherwise specifically designed.</li> <li>▶ Access between levels of a multi-tiered cradle should be fitted with:               <ul style="list-style-type: none"> <li>◊ Protective mesh.</li> <li>◊ Hinged trapdoors or sliding hatches.</li> </ul> </li> <li>▶ If there is no access between levels, then the scaffold should be able to be operated from any level.</li> </ul>
Protection and Safety	<ul style="list-style-type: none"> <li>▶ Netting, if fitted to prevent materials falling from the cradle, should:               <ul style="list-style-type: none"> <li>◊ Be constructed of galvanised wire mesh, at least 1.5mm thick.</li> <li>◊ Have wires spaced at least 20mm apart.</li> <li>◊ Be fixed between the toe-board and guardrail on all sides.</li> </ul> </li> <li>▶ Overhead protection may need to be installed above a cradle if there is a likelihood of debris falling onto the scaffold.</li> </ul>
Control Boxes	<ul style="list-style-type: none"> <li>▶ Should be fully enclosed, lockable and protected from shock or environmental damage.</li> <li>▶ Should be attached to the inside of the guardrails away from the working face.</li> <li>▶ They should be removable, so they can be secured safely when not in use.</li> <li>▶ Should be fitted with:               <ul style="list-style-type: none"> <li>◊ Socket outlets for hoists.</li> <li>◊ A power on light indicator.</li> <li>◊ An emergency stop button.</li> </ul> </li> </ul>
Rated Capacity	<ul style="list-style-type: none"> <li>▶ Should be displayed on a sign inside the cradle.               <ul style="list-style-type: none"> <li>◊ Articulated and multi-tiered cradles should have the rated capacity displayed in each bay.</li> </ul> </li> <li>▶ Always make sure that all materials are evenly distributed across the cradle.</li> </ul>

## Hoists

Requirements for hoists which should be checked for include:

Item	Requirements
Protective Devices	<ul style="list-style-type: none"> <li>▶ Most hoists should have built-in or independently mounted protection devices to act as an emergency brake in the event that the suspension rope is broken.</li> <li>▶ A double rope suspension scaffold does not need a protective device for each scaffold.</li> </ul>
Load Limiter	<ul style="list-style-type: none"> <li>▶ Electric hoist should be fitted with:               <ul style="list-style-type: none"> <li>◆ Load limiting device to stop the hoist damaging the suspension rope or toppling the suspension rig, if the scaffold becomes jammed.</li> </ul> </li> <li>▶ Electrically powered suspension scaffold must be fitted with:               <ul style="list-style-type: none"> <li>◆ Load limiting device with a maximum setting of 1.25 x the rated capacity of the hoist or 125%, to prevent overloading.</li> </ul> </li> </ul>
Data Plates	<ul style="list-style-type: none"> <li>▶ All suspended scaffolding should have legible data plates with the following information:               <ul style="list-style-type: none"> <li>◆ Serial number.</li> <li>◆ Type/model identification.</li> <li>◆ Name/identification mark of the manufacturer.</li> <li>◆ Rated capacity.</li> <li>◆ Size, maximum length, grade and construction of Flexible Steel Wire Rope (FSWR) (where applicable).</li> <li>◆ Reeving and power supply requirements (where applicable).</li> </ul> </li> </ul>

Scaffolding hoists should be designed, manufactured and tested in accordance with the Australian Standard AS 1418.2 – Scaffolding Hoists.

Always make sure a purpose-made weatherproof cover is fitted to all scaffold hoists to prevent contamination of the working mechanisms.

## Suspension and Secondary Ropes

It is important that all suspension and secondary ropes must meet the requirements of the scaffold. These include:

Item	Requirements
Rope Arrangement and Requirements	<ul style="list-style-type: none"> <li>▶ Suspension and secondary ropes should be the correct size and construction for the hoist or protective device used. They should have a swaged and thimble eye at one end.</li> <li>▶ There should be at least 1m of spare rope when a climber-type scaffolding hoist is at its lowest point. Excess rope should be protected from damage by coiling and tying or by being placed around a rope winder.</li> <li>▶ At least 3 turns of rope should remain on the drum when a drum-type scaffolding hoist is at its lowest point. The drum flange should extend 2 rope diameters beyond the built-up rope on a fully-loaded drum-type scaffolding hoist.</li> </ul>

	<ul style="list-style-type: none"> <li>▶ When replacing the FSWR on a climber hoist it is important that the same FSWR construction and size are used to help prevent the FSWR from being seriously damaged as it runs over the sheaves and sever the FSWR.</li> </ul>
Rated Capacity of Suspension Rope	<ul style="list-style-type: none"> <li>▶ The rope tension on a shackle supporting a suspension rope should be no more than 80% of the shackles rated capacity.</li> <li>▶ The rope tension on a choked sling supporting a suspension rope should be no more than 40% of the slings rated capacity.</li> </ul>
Secondary Wire	<ul style="list-style-type: none"> <li>▶ Secondary wire ropes should be attached to the suspension rigging independent of the main suspension rope, never use the counter weights to support a needle that supports two (2) suspension ropes.</li> </ul>

## Suspension Rigs

You should ensure that the suspension rig is adequate for the scaffold. Requirements you should check for include:

Item	Requirements
Suspension Rig	<ul style="list-style-type: none"> <li>▶ Must remain rigid and stable under working conditions.</li> <li>▶ The design should consider all forces and load (e.g. wind loads).</li> <li>▶ A reveal propped needle suspension rig: <ul style="list-style-type: none"> <li>◆ Should have at least two rows of uprights fixed with ledgers and transoms as well as longitudinal, transverse and plan bracing systems.</li> <li>◆ Needles can be fixed onto or under the reveal props.</li> <li>◆ Close fitting U-heads may be used with rolled steel joists or universal beams.</li> </ul> </li> </ul>
Needle or Supporting Beam	<ul style="list-style-type: none"> <li>▶ Should always be mounted with the greater vertical dimension.</li> <li>▶ The outboard end of a needle should never be lower than the inboard end.</li> <li>▶ A beam spanning between only two supports should always be horizontal.</li> </ul>
Anchors	<ul style="list-style-type: none"> <li>▶ If anchorage bolts are used, they should be kept from loosening (e.g. with lock nuts).</li> <li>▶ Do not use friction or chemical insert anchors on needles.</li> <li>▶ Through bolts, props or bracket bolts are recommended for fixing the rig/needle in place.</li> </ul>
Props	<ul style="list-style-type: none"> <li>▶ If using props, they should be installed to the top of the needle and to the underside of the floor above.</li> <li>▶ You must make sure that the props are correctly fixed to stop any movement or dislodgement: <ul style="list-style-type: none"> <li>◆ Have a competent person (such as an engineer) check that the floor is able to withstand the force of the props and scaffold.</li> </ul> </li> </ul>

## Tracks and Trolleys

All tracks and trolleys must meet the following requirements:

Item	Requirements
Tracks and Trolleys	<ul style="list-style-type: none"> <li>▶ Traversing tracks are hung beneath needles or supported by beams. The ends should be fitted with through bolted stops to stop trolleys running off the track.</li> <li>▶ The trolley supporting a suspension rope should have a rated capacity of at least 500 kg, or the load limiter setting – whichever is greater.</li> <li>▶ A spacer tie or spreader bar can be used to stop two trolleys from spreading (moving apart) while supporting a swing stage.</li> <li>▶ Trolleys supporting a double rope suspended scaffold should be rigidly connected with plan braced to stop twisting.</li> <li>▶ Ropes used for horizontal movement of a suspended scaffold should be a minimum 12mm diameter fibre rope.</li> </ul>

## Calculations for Suspended Scaffolds

Calculating maximum rope tension for an electric hoist:

$$\text{MAXIMUM Rope Tension} = (\text{Hoist Rated Capacity in kg} \times 1.25 \text{ (LLD)}) + (\text{DL (of wire) per 100m (kg)} \div 2)$$

Where DL = Dead Load.

**NOTE:** AS 1576 Clause 4.5 Load-Limiting Device states that electrically powered scaffolding hoists shall have a device to limit the lifting capacity of the hoist to a maximum 1.25 times the rating of such hoist. And Clause 4.7 Rope Tension states that rope tension for electrically powered scaffolding hoists is the summation of the load which is limited by the load limiting device, the gravitational load of the suspension rope and the tensioning weight.

Calculating maximum rope tension for a manual hoist:

$$\text{Maximum Rope Tension} = (\text{DL per 100m (kg)} \div 2) + \text{DL of hoist} + (\text{Weight of cradle} \div \text{Number of Needles}) + \text{Rated Capacity of Cradle}$$

Where DL = Dead Load.

Calculating rope minimum guaranteed breaking load for an electric hoist:

$$\text{MINIMUM Guaranteed Breaking Load} = \text{Hoist Rated Capacity} \times 10$$

Calculating rope minimum guaranteed breaking load for a manual hoist:

$$\text{MINIMUM Guaranteed Breaking Load} = \text{Hoist Rated Capacity} \times 7$$

## Safety Factors

**NOTE:** AS 1418 Clause 5.4.2 Ropes and reeved systems states that the safety factor of the wire rope based on the minimum breaking load shall be not less than:

- ▶ 10 for power-operated scaffolding hoists.
- ▶ 7 for hand-operated scaffolding hoists.

## Stability for Cantilevered Needles

The ratio of stability of a cantilevered scaffold incorporating cantilevered needles must be not less than three, where the ratio of stability is the sum of the moments acting on the inboard portion of the needles divided by the sum of the moments acting on the outboard portion of the rig (3 inboard:1 outboard Ratio).

### Calculating counterweight requirements for needle stability:

The formula for calculating the number of counterweights needed on each needle of a cantilevered suspension rig is -

$$\text{Number of Counterweights} = \frac{3 \times (\text{Rope Tension in kg}) \times (\text{Outboard in metres})}{\div (\text{Inboard in metres}) \div (\text{mass of each counterweight in kg})}$$

For Example:

Counterweights	=	25kg each
Maximum Rope Tension	=	700kg
Outboard	=	0.9m
Inboard	=	3.6m
Therefore		$3 \times 700 \times 0.9 \div 3.6 \div 25 = 21$ counterweights per needle



Include the following factors in calculations of the inboard moments:

- ▶ The self-weight of the inboard portion of the suspension rig, including any counterweights
- ▶ The design load of anchorages and props
- ▶ The strength of the supporting structure
- ▶ The distance between the fulcrum and the inboard end of the suspension rig

Consider the following in calculations of the outboard moments:

- ▶ The self-weight of the outboard portion of the suspension rig, including trolley tracks and trolleys
- ▶ The mass of secondary ropes, traversing ropes, electrical cables and compressed air cables
- ▶ The distance between the fulcrum and the suspension rope attachment points
- ▶ The maximum rope tension
- ▶ Where the scaffolds incorporate trolley tracks, the most adverse horizontal position of the cradle should be considered when calculating the ratio of stability

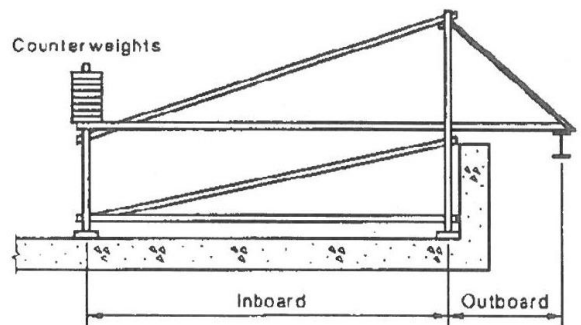

(b) Traversing track supported by truss

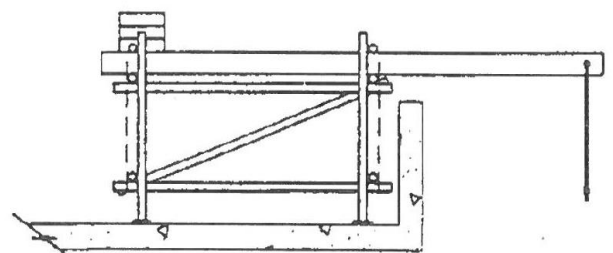

(c) Needle supported by tube and coupler rostrum

### Electric Hoist

Hoist Type & Capacity	Configuration of Needles	Individual Cradle	Work Cage	Boatswains Chair
<ul style="list-style-type: none"> <li>• Electrical</li> <li>• Rated capacity 750kg</li> <li>• Suspension rope dead load 36kg/100m</li> <li>• 50m rope length on each needle</li> <li>• Load limit device set at max. allowable overload</li> </ul>	<ul style="list-style-type: none"> <li>• Each needle has an outboard of 0.75m</li> <li>• Inboard 4m</li> <li>• *Counterweights weigh 25kg each</li> </ul> <p><i>*most commonly used however confirmation of actual counterweight must be established</i></p>	<ul style="list-style-type: none"> <li>• 2 suspension ropes</li> <li>• 2 hoists (1 per needle)</li> <li>• 2 needles</li> <li>• Cradle dead load 100kg</li> <li>• Cradle SWL 250kg</li> </ul>	<ul style="list-style-type: none"> <li>• 1 suspension rope</li> <li>• 1 hoist</li> <li>• 1 needle</li> <li>• Work cage dead load 75kg</li> <li>• Work cage SWL 200kg</li> </ul>	<ul style="list-style-type: none"> <li>• 1 suspension rope</li> <li>• 1 hoist</li> <li>• 1 needle</li> <li>• Chair dead load 15kg</li> <li>• Chair SWL 150kg</li> </ul>

Maximum Rope Tension (MRT) =

Hoist Rated Capacity (HRC) x Load Limit Device Safety Factor (LLDSF) + (Dead Load/Suspension Rope/100 ÷ 2) = MRT (kg)

**Example**       $750\text{kg} \times 1.25 + (36\text{kg}/100\text{m} \div 2) = 955.5 \text{ kg}$

YOUR WORKINGS – Outboard = 0.5m, Inboard = 3m

Calculate Below

Minimum Guaranteed Breaking Strain (Load) (MGBS) =

Hoist Rated Capacity (HRC) x Safety Factor (SF - Electric) = MGBS (kg)

**Example**       $750\text{kg} \times 10 = 7500 \text{ kg}$

YOUR WORKINGS – Outboard = 0.5m, Inboard = 3m

Calculate Below

Number of Counterweights required per Needle =

$3 \times \text{Maximum Rope Tension (MRT)} \times \text{Outboard (O.B)} \div \text{Inboard (I.B)} \div \text{weight of counterweight} = \text{No. of counterweights per needle}$

**Example**       $3 \times 955.5\text{kg} \times 0.75\text{m} \div 4\text{m} \div 25\text{kg} = 21.49$       therefore 22 counterweights required per needle (round up)

YOUR WORKINGS – Outboard = 0.5m, Inboard = 3m

Calculate Below

### Manual Hoist

Hoist Type & Capacity	Configuration of Needles	Individual Cradle	Work Cage	Boatswains Chair
<ul style="list-style-type: none"> <li>Manual</li> <li>Rated capacity 350kg</li> <li>Dead load 35kg</li> <li>Suspension rope dead load 26kg/100m</li> <li>50m rope length on each needle</li> <li>Load limit device set at max. allowable overload</li> </ul>	<ul style="list-style-type: none"> <li>Each needle has an outboard of 0.75m</li> <li>Inboard 4m</li> <li>* Counterweights weigh 25kg each</li> </ul> <p><i>* most commonly used however confirmation of actual counterweight must be established</i></p>	<ul style="list-style-type: none"> <li>2 suspension ropes</li> <li>2 hoists (1 per needle)</li> <li>2 needles</li> <li>Cradle dead load 100kg</li> <li>Cradle SWL 250kg</li> </ul>	<ul style="list-style-type: none"> <li>1 suspension rope</li> <li>1 hoist</li> <li>1 needle</li> <li>Work cage dead load 75kg</li> <li>Work cage SWL 200kg</li> </ul>	<ul style="list-style-type: none"> <li>1 suspension rope</li> <li>1 hoist</li> <li>1 needle</li> <li>Chair dead load 15kg</li> <li>Chair SWL 150kg</li> </ul>

Maximum Rope Tension (MRT) =

$(\text{Dead Load per 100m} \div 2) + \text{Dead Load of hoist} + (\text{weight of Cradle} \div \text{Number of Needles}) + \text{Rated Capacity of Cradle} = \text{MRT (kg)}$

**Example**  $(26 \div 2) + 35 + (100\text{kg} \div 2) + 250\text{kg} = 348 \text{ kg}$

YOUR WORKINGS – Outboard = 0.5m, Inboard = 3m

Calculate Below

Minimum Guaranteed Breaking Strain (Load) (MGBS) =

$\text{Hoist Rated Capacity (HRC)} \times \text{Safety Factor (SF - Electric)} = \text{MGBS (kg)}$

**Example**  $350\text{kg} \times 7 = 2450 \text{ kg}$

YOUR WORKINGS – Outboard = 0.5m, Inboard = 3m

Calculate Below

Number of Counterweights required per Needle =

$3 \times \text{Maximum Rope Tension (MRT)} \times \text{Outboard (O.B)} \div \text{Inboard (I.B)} \div \text{weight of counterweight} = \text{No. of counterweights per needle}$

**Example**  $3 \times 348\text{kg} \times 0.75\text{m} \div 4\text{m} \div 25\text{kg} = 7.83$  therefore 8 counterweights required per needle (round up)

YOUR WORKINGS – Outboard = 0.5m, Inboard = 3m

Calculate Below

## Erecting Scaffold Equipment

### Scaffold - All Levels

#### Installing A Static Line

There are many types of fall- arrest systems available. One of the most common types associated with scaffolding operations is called a 'Static Line'.

Static lines are horizontal lines to which a lanyard may be attached and which is designed to arrest a free fall.

These provide a suitable anchor point for a fall- arrest system, while still allowing a limited range of movement along the path of the line.

It is important that the static line is properly tensioned.

Generally, the maximum allowable length of a single span of static line is 6m. For a static line this long the maximum allowable sag is 300mm (calculated as 50mm per metre).

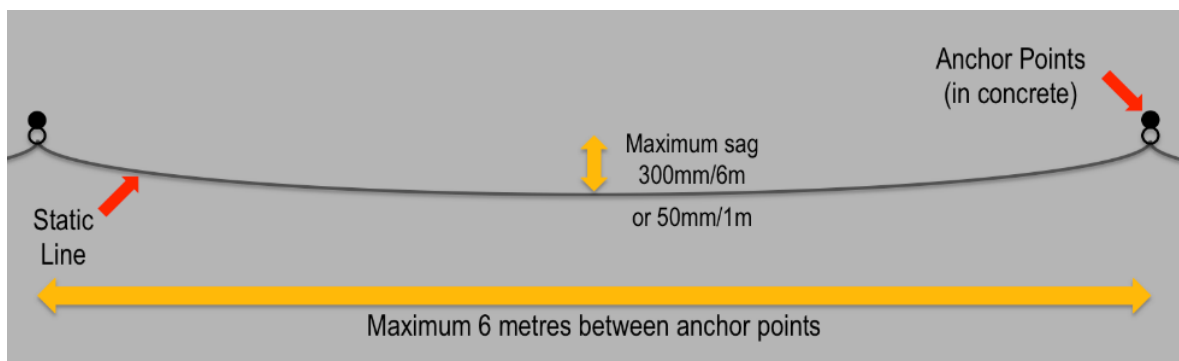

A ratchet and pawl, or similar tensioning device, can be used to tension the static line **IF** permitted by the manufacturer or engineer and the amount of tensioning has been specified.

Any separate tensioning devices should always be removed from the static line once tensioning is complete.

These lines must be installed and checked regularly by a competent person and must only be used in accordance with the manufacturer's specifications, including limits relating to the number of workers connected to the line at one time.

Wherever possible, life lines and static lines should be as high as the situation safely allows to limit the free fall distance of workers connected to it. Generally, this should not be less than 2.1m from the floor of the work area.

Life and static line anchors must be rated appropriately for the situation and number of workers.

#### Anchor Points



Anchor, or anchorage, points should be located as high as equipment permits, as it is safer to work below the point of anchorage.

Where the anchorage point is below the harness connection point, a shorter or an adjustable lanyard may be required.



Non- manufactured anchor points on a single span static line, used for scaffolding operations needs to be capable of holding a weight of 4 tonnes (40 kn).

You can determine the capabilities of an anchorage by checking the manufacturer's specifications and installation instructions, or seeking engineers advice in writing.

Anchorage and lines between supports should be positioned on the inside face of columns where practicable and used to anchor static lines, or the static line may pass through a cavity tube cast in concrete for that purpose.

Static lines between supports must be free of obstructions to allow uninterrupted movement for persons who may be attached to the line. If a line passes around a column, corner, or other sharp edge, it should be packed to prevent damage to the line.

Static lines may be secured at each end using suitable equipment such as:

- ▶ Double saddle clamps
- ▶ Machine splice with thimble eye
- ▶ Suitable wedge and sockets
- ▶ Purpose-designed fittings such as swaged or pressed fittings

However, if the static line is being installed into concrete you must use approved anchorages such as:

- ▶ Cast in anchorages
- ▶ Chemical
- ▶ Friction

**These types of anchor points must first be assessed and approved by a competent person such as an experienced engineer, to ensure the correct rating / proof load tested and integrity are sufficient.**

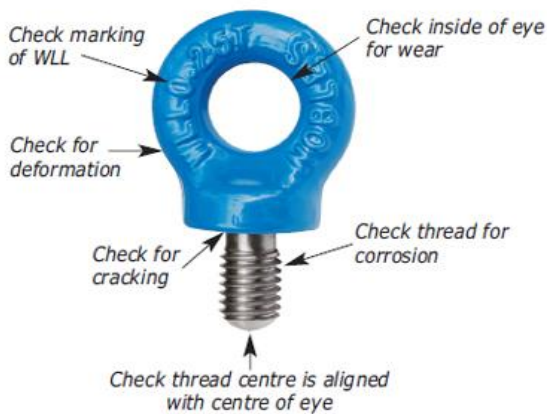

Eyebolts may be used as anchorage points; however, you must make sure they are collared as these can withstand more sideways pressure than plain or un-collared eyebolts. Collared eyebolts help to spread the load and assist in ensuring that the eyebolt does not shear at the bolt point.



Turnbuckles may be used to attach static lines to eyebolts as long as they are open-framed, allowing for inspection.



### Strength Requirement for Anchorages

Purpose of Anchorage (single point anchorages)	Ultimate strength in direction of loading (minimum)
Free Fall-arrest – one (1) person	15 Kn
Free Fall-arrest – two (2) persons attached to same anchor	21 Kn
Limited free fall-arrest (including rope access anchorages)	12 Kn
Restraint technique	12 Kn

## Scaffold Basic Level

### Installing a Materials Hoist

When setting up near a trench, the distance between the base of the tower and the edge of the trench must be greater than the depth of the trench (e.g. 3m away from a 2m trench).

At the base of the tower a handrail, with a moveable or sliding rail to allow access to the platform, must be set back at least 600mm from the working platform to stop people from leaning over and being hit by the moving platform.

The landing gate for the platform must be a minimum of 1.8m high.

On the floors above, a handrail must be placed 600mm from the edge of floors to prevent people falling off.

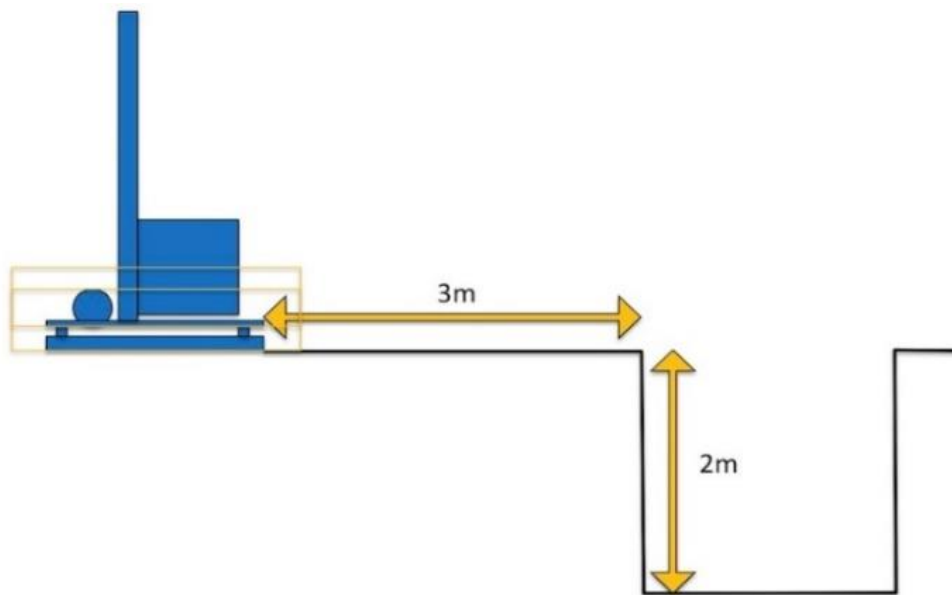

There must be an overhead guard to protect the operator from falling objects.

The hoist must not be set up in front of any access way to a building (such as a doorway or a window) unless it is blocked off to stop people leaning out and being hit by the passing platform.

The gap between the platform floor and the building floor must be no less than 25mm and no more than 100mm.

The tower must be guyed or tied every 6m and have no more than 3m free standing above the top tie (unless otherwise specified by the manufacturer).

Guy ropes must be at least 9mm in diameter for hoists to 500kg capacity and at least 12mm for more than 500kg (and 6 x 19 construction).

The minimum over-run distance between the hoist rope attachment and the head sheave is 1.5m.

Once the hoist is completed check that it complies with the installation specifications. You also need to make sure you install signage displaying the Working Load Limit (WLL) of the hoist.

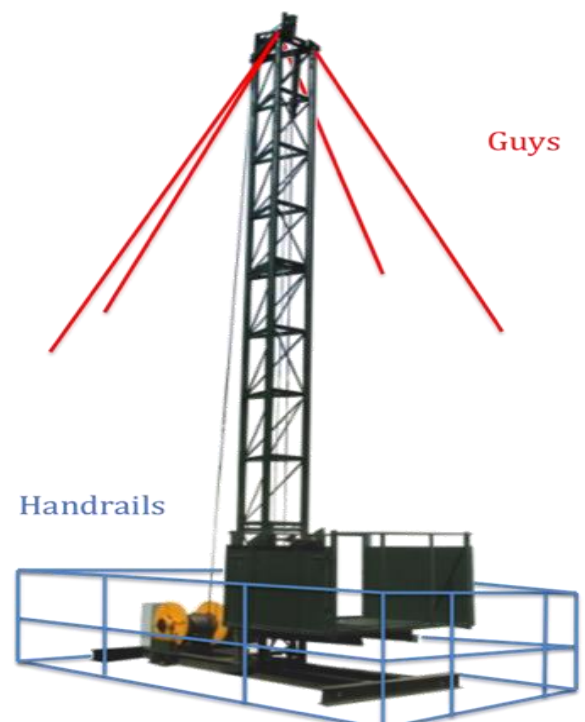

## Scaffold Work Platform Requirements

When positioning the planks for the working platform you need to make sure that any gaps between the planks do not exceed 10mm and that all planks are the same thickness.

Using planks that are different thicknesses can cause a tripping hazard. The planks can be overlapped on the returns (corners) of a scaffold.

It is important that there is enough space on the work platform for the tasks that need to be carried out. Make sure there is enough clear access on all working platforms:

Situation	Minimum clear access on work platform
Workers using hand tools	450mm
Workers and materials	675mm

The minimum clear access on a non-working platform is 2 boards / 450mm.

If a bay extension platform is being installed at a level where there are working platforms above and below it (at standard 2m lift distances), the additional ledgers and transoms need to be installed in the same bay as the extension platform.

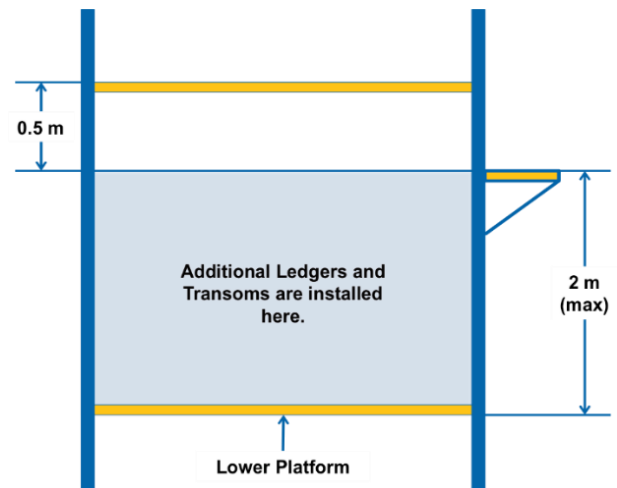

## Platform Brackets

The minimum platform width when platform brackets are fixed between lifts is 450mm (or 2 planks).

Platform brackets are generally fixed on the working face of the scaffold but may be fixed on the outside in some situations.

When fixing platform brackets between lifts, place the extra working platforms at the lift directly above and the lift directly below. In these situations further precautions need to be considered, such as fans, crash decks etc.

### Tie Bars

- ▶ Must have a tie-bar on the front face in between
- ▶ Must have a ledger or transom (handrails) at the extension platform level
- ▶ One board platform brackets can only be used to extend an existing deck
- ▶ Maximum distance between the platform edge and the working face is 225mm



## Tank Brackets



The maximum spacing used between tank brackets supporting **32mm thickness solid timber scaffold planks is 1m.**

The maximum spacing used between tank brackets supporting **38mm thickness solid timber scaffold planks is 1.5m.**

The maximum spacing used between tank brackets supporting **50mm thickness solid timber scaffold planks is 2m.**

The maximum spacing used between tank brackets supporting **63mm thickness solid timber scaffold planks is 2.5m.**

## Guardrail and Edge Protection Requirements



Adequate edge protection needs to be installed on all scaffolds where a person or object could fall more than 2m.

Basic edge protection on a scaffold is made up of three (3) main parts:

- ▶ Guardrails
- ▶ Mid-rails
- ▶ Toe boards (or kick- boards)

Guardrails may be scaffold tubes, purpose-designed components (particularly when using prefabricated scaffolding systems) or oregon, hardwood or other timber (of equivalent strength) that is at least 100mm x 50mm.

Under no circumstance can ropes (fibre or fswr) or chains be used as guardrails.

The gap between an unprotected edge and the working face (structure or building) must not exceed 225mm.

The gap between the kickboard and the platform/deck should not exceed 10mm.

Where the nature of the work makes it difficult for a person to be fully aware of the proximity of the platform edge (e.g. overhead work or welding), edge protection should be provided regardless of the height of the platform.

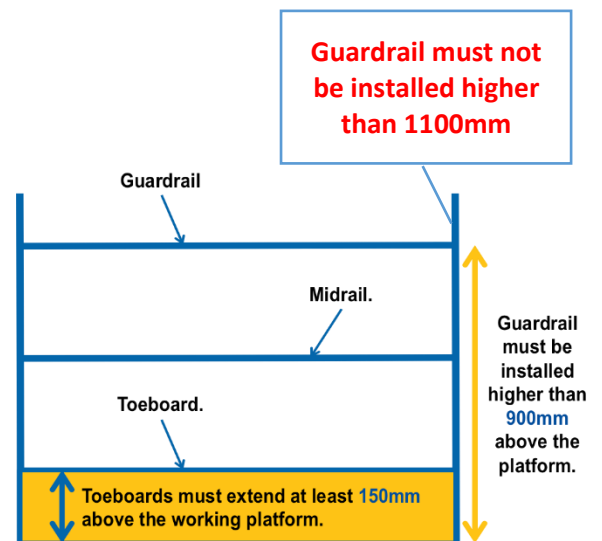

Item	Requirements
Edge Protection	<ul style="list-style-type: none"> <li>▶ Required where a person could fall more than 2m.</li> <li>▶ Scaffold tube, purpose designed component or hardwood may be used for a guardrail. Fibre rope, flexible steel wire rope (FSWR) and chain must never be used as a guardrail.</li> <li>▶ Guardrail should be positioned between 900mm and 1100mm from the work platform surface.</li> <li>▶ Toe boards must extend at least 150mm above the surface of the working platform.</li> <li>▶ Mid-rails, infill, brick guards or mesh must be positioned between the toe board and the guardrail.</li> </ul>

## Installing Ladder Access

Where practical, ladders should be installed internally.

Ladders may be used to provide access to scaffolds.

It is important that ladders are secured correctly and that the appropriate safety measures are adhered to when installing and using them.

A ladder must extend at least 900mm, ideally 1m above the work platform.

Ladder access should be fitted in a position of a 4:1 minimum and a maximum 6:1 vertical to horizontal ratio.

Where ladders are used between working platforms, the maximum height allowed between platforms is 4m or 2 lifts (AS/NZS 1576.1:2010).

Where ladder access is installed within the scaffold (such as with mobile frame scaffolds) through the floor of the working platform it is important that the opening is adequately protected.

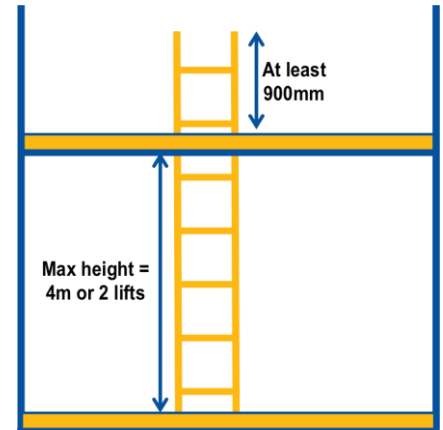

Item	Requirements
Access	<ul style="list-style-type: none"> <li>▶ Single industrial grade ladders may be used to access working platforms. Domestic grade or extension ladders must not be used.</li> <li>▶ Ladder access should be fixed in a position between 6:1 max and 4:1 min vertical to horizontal.</li> <li>▶ The minimum height that a portable access ladder must extend above the landing is 900mm.</li> <li>▶ Access ramps may have a slope of up to 20° (1:3) as long as they are cleated to prevent slip hazards. Cleats should be 50 mm wide and 25mm thick and fixed at intervals of 450mm.</li> </ul>

## Bracing and Ties

### Bracing

Bracing is used both **longitudinally and transversely** on a scaffold structure. The supplier or manufacturer will supply basic design criteria for locations of bracing.

When either manufacturers or suppliers **do not** supply bracing design, the following recommendations must be followed.

### Longitudinal Bracing

The outside row of standards in the scaffold shall be provided with longitudinal bracing that:

- ▶ Extends from the base of the scaffold to its full height (working deck);
- ▶ Is provided in both end bays of every scaffold run;
- ▶ Is arranged –
  - ◆ Across the longitudinal plane of the bays, forming diagonal bracing;
  - ◆ Up a bay, forming parallel bracing; or
  - ◆ Up a bay, forming heel-and-toe bracing
- ▶ Has any brace in sections joined by lapping or splicing; and
- ▶ Is fixed, as close as possible to the node points at every crossing, to –
  - ◆ The standard crossed with a swivel coupler; or
  - ◆ The transom crossed with a right-angle coupler.



The horizontal distance between intermediately braced panels in any lift shall not exceed three bays.

## Transverse Bracing

Each end of the scaffold shall be provided with transverse bracing in each lift that -

- ▶ Extends from the base of the scaffold to its full height (working deck);
- ▶ Is arranged across the transverse plane of the bay, forming diagonals; and
- ▶ Is fixed, as close as possible to the node points at every crossing, to –
  - ◆ The standard crossed with a swivel coupler; or
  - ◆ The ledger crossed with a right-angle coupler.

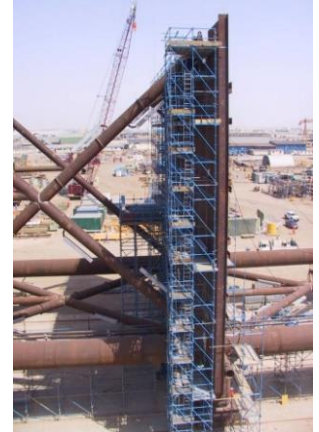

## Plan Bracing

- ▶ Horizontally between diagonally opposite standards
- ▶ Must be in the base lift of all mobile scaffolds
- ▶ Used to increase the horizontal distance between ties and improve rigidity and squareness

## Ties

Ties are used to fix a scaffold to a building or steelwork. This keeps the scaffold erect, level and stable. They are most commonly connected to the scaffold using a right-angle coupler.

Ties need to be arranged correctly to provide stability to the scaffold. Ties need to be spaced vertically and horizontally, taking into account the strength of both the tie assembly and the supporting structure.

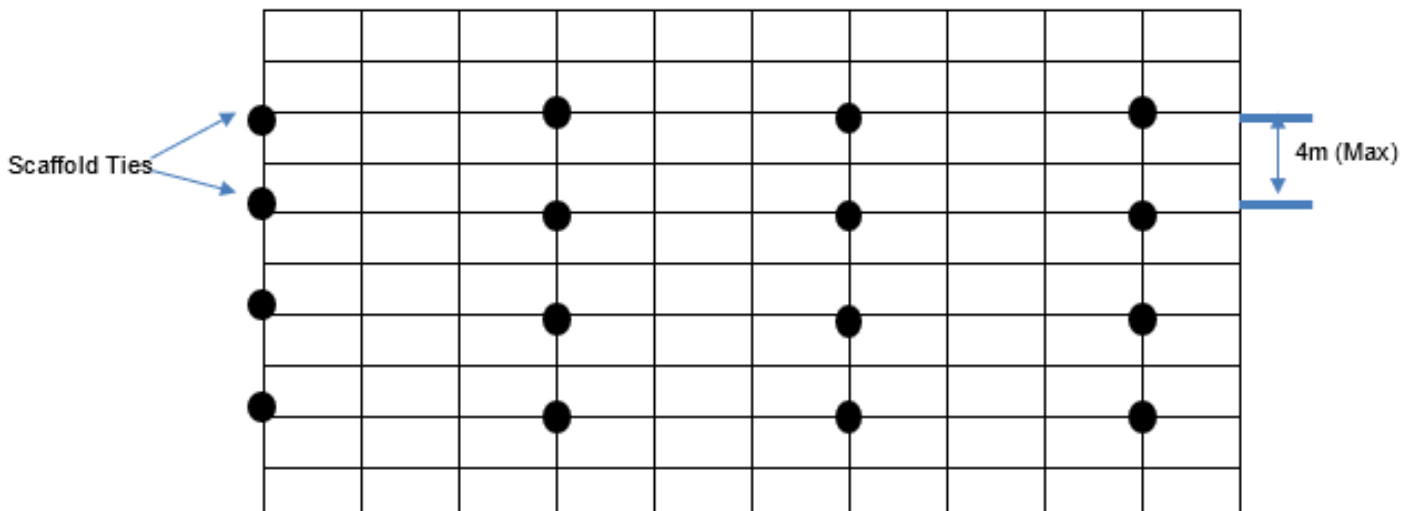
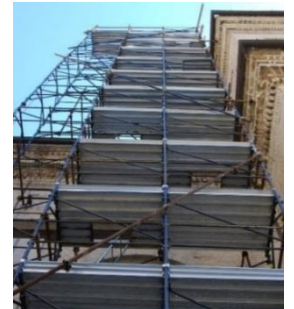

Tie assemblies may include:

- ▶ Box tie
- ▶ U Tie
- ▶ Through Tie
- ▶ Double Lip
- ▶ Column

### Excess Equipment

Any excess equipment should be removed from the area as soon as practicable to maintain a high standard of housekeeping.

When using plan bracing to increase the tie spacing on a tube and fitting scaffold, you would strengthen each tie by fixing check couplers (or additional couplers) to the tie tubes.

Where the height of a scaffold exceeds three (3) times its least base width, the scaffold shall be tied to a supporting structure, and –

- ▶ Each tie shall be rigidly connected to the supporting structure and fixed to prevent inwards and outwards movements of the scaffold. Drilled-in anchors and other methods relying on friction between components and the supporting structure shall not be used unless it is not practicable to use other methods. Where drilled-in anchors are used, they must have a safety factor of 3, and a competent person must assess the suitability of the supporting material.
- ▶ Each tie shall be connected to not less than two (2) standards or two (2) ledgers with right-angle couplers;
- ▶ A tie tube shall be a full-length tube without joints;
- ▶ The distance between the end of the scaffold and the first tie at any level shall not exceed –
  - ◆ One (1) bay in the case of a scaffold with no return;
  - ◆ Three (3) bays in the case of a scaffold with a tied return;
- ▶ The distance between longitudinally adjacent ties at any level shall not exceed three (3) bays;
- ▶ The vertical distance between the supporting surface and the first level of ties shall be not more than three times the least base width, subject to a maximum of 4m;
- ▶ The vertical distance between adjacent levels of ties shall not exceed 4m; and
- ▶ The location of ties shall not obstruct clear access along the full length of any working platform or access platform.

NOTE:

1. A transom of extended length may act as a tie tube.
2. It is good practice to vertically stagger the ties.

The method you select will be determined by the building or structure that the scaffold is being tied to.

## Tie Examples

### Box Tie

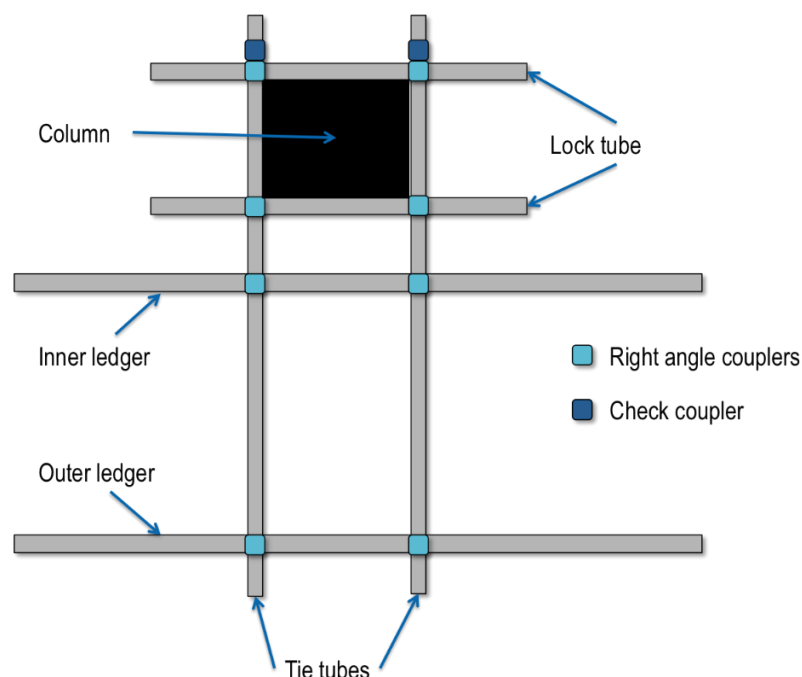

**U-tie**

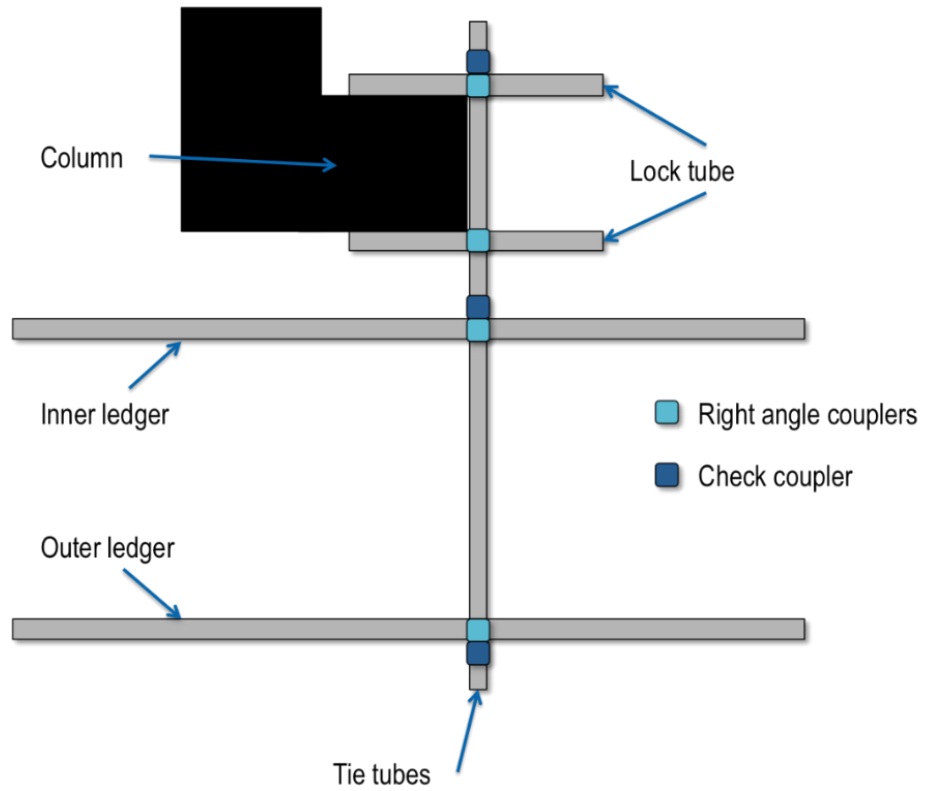

**Through Tie**

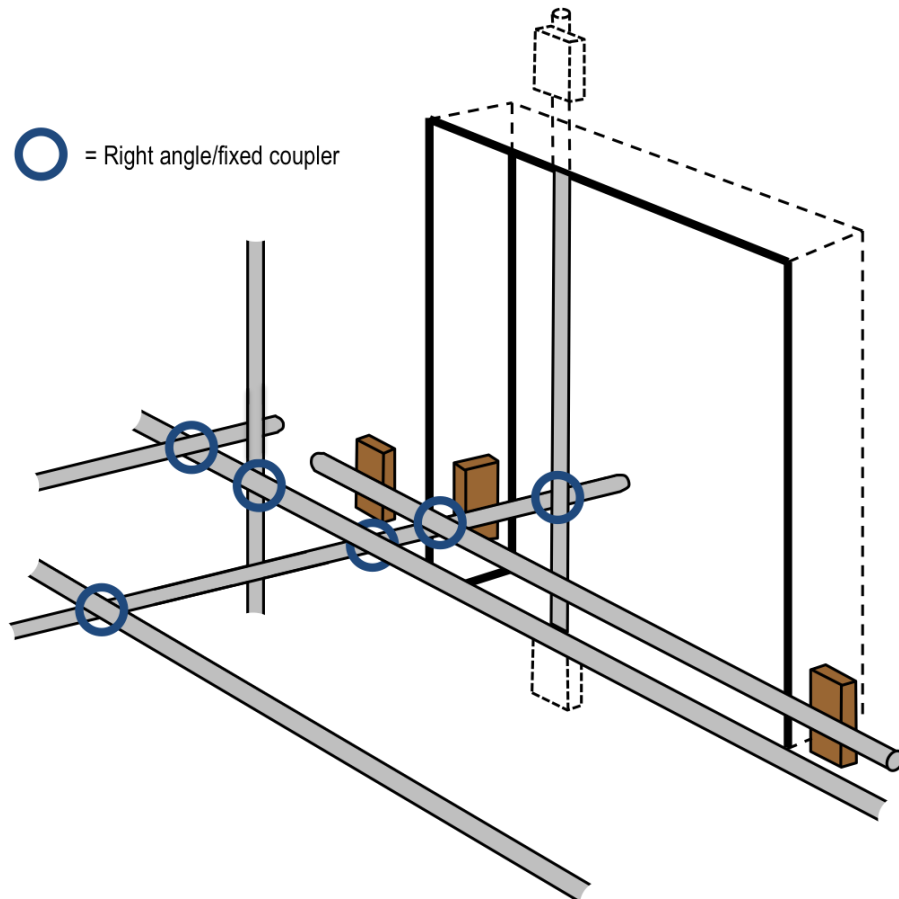

## Double Lip

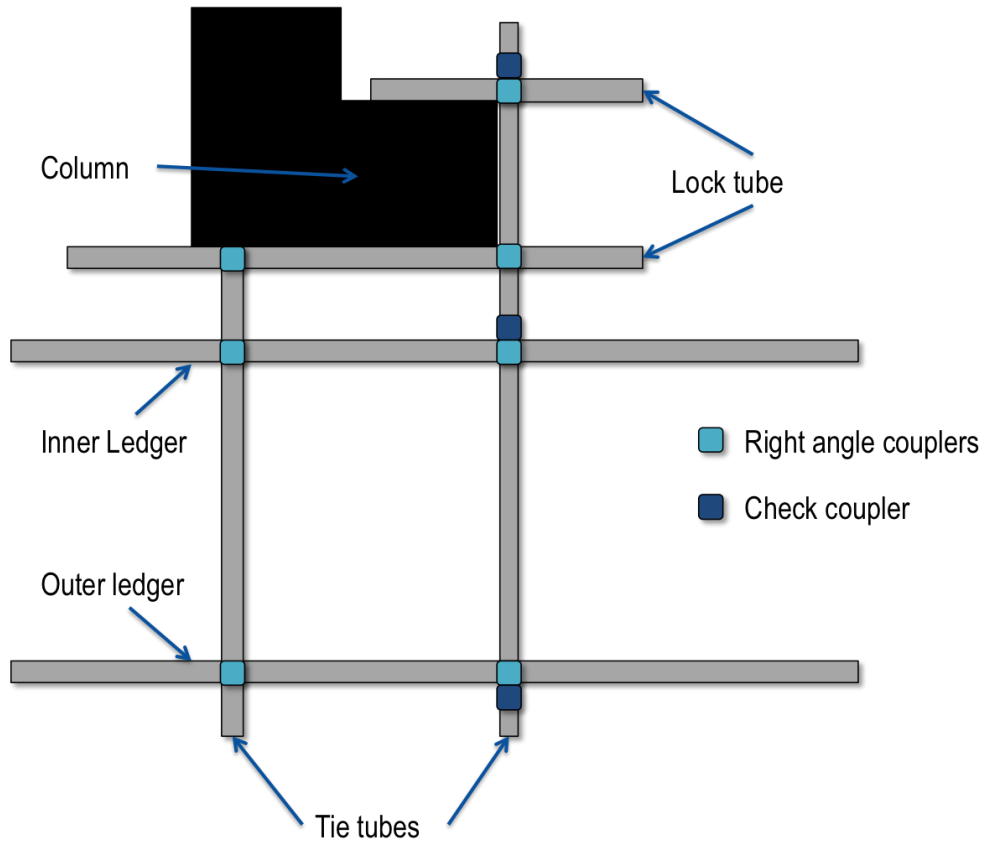

## Column Tie

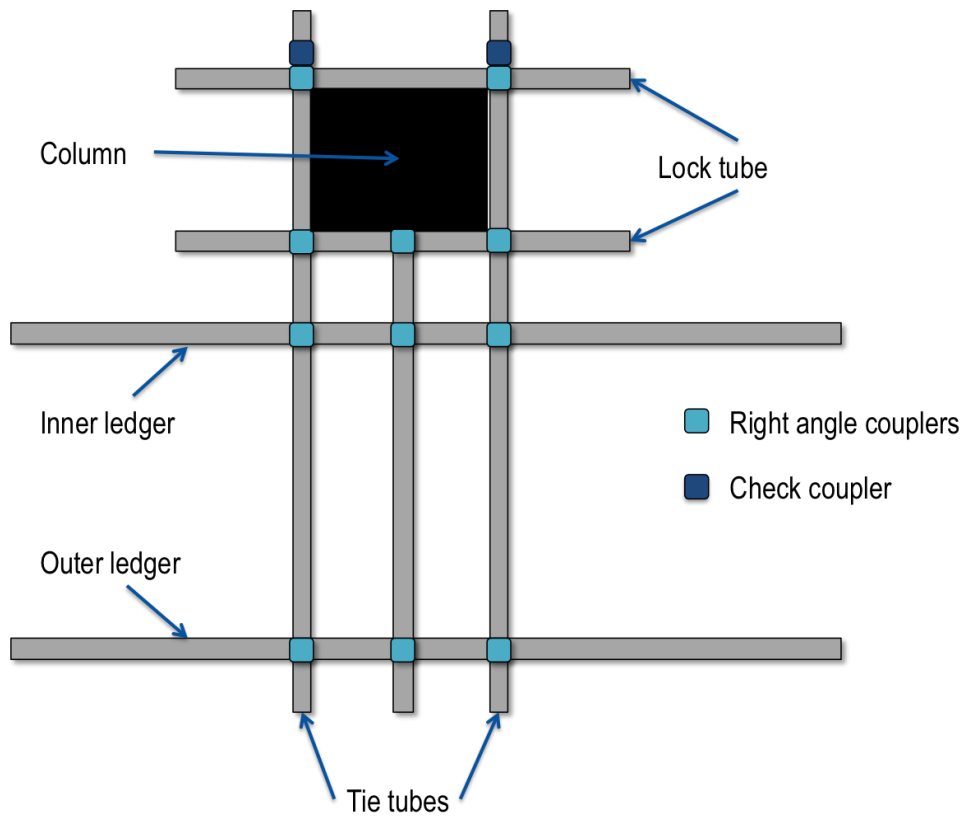

## Scaffold Intermediate Level

### Cantilevered Scaffold

#### Cantilevered Platform Requirements

When putlogs are cantilevered so that extra planks can be used the bay should be at least 950mm (four planks) wide.

Two 225mm planks can be supported by the cantilevered portion of the putlogs (maximum without installing spurs/rakers).

This can be done by ensuring the transom beneath the cantilevered platform is extended to support another ledger on the working face and by using putlog clips to connect the putlogs to all three ledgers. Minimum inboard of 950mm (or 4 boards) is required.

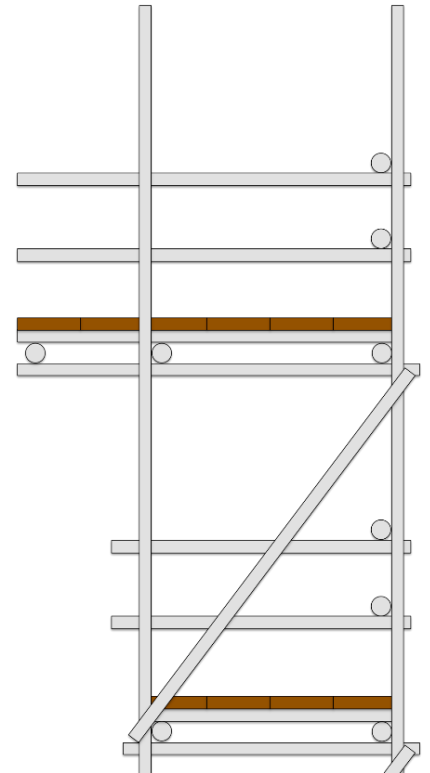

### Erecting A Cantilevered Scaffold

Cantilevers scaffolds are set up on cantilevered steel members called 'needles'.

A steel beam used as a needle for a cantilevered scaffold should be at least 75mm wide. It should be positioned so that 75% or  $\frac{3}{4}$  of its length is 'inboard' and supporting the cantilevered section known as 'outboard'.

Anchorage bolts should have lock nuts to stop them loosening. Anchorage bolts should be at least 15mm in diameter at the inboard end of a needle (do not use drilled-in anchors).

The first lift of ledgers and transoms on a cantilevered scaffold should be as close as possible to the needles.

The scaffold should be tied to the building at the first lift.

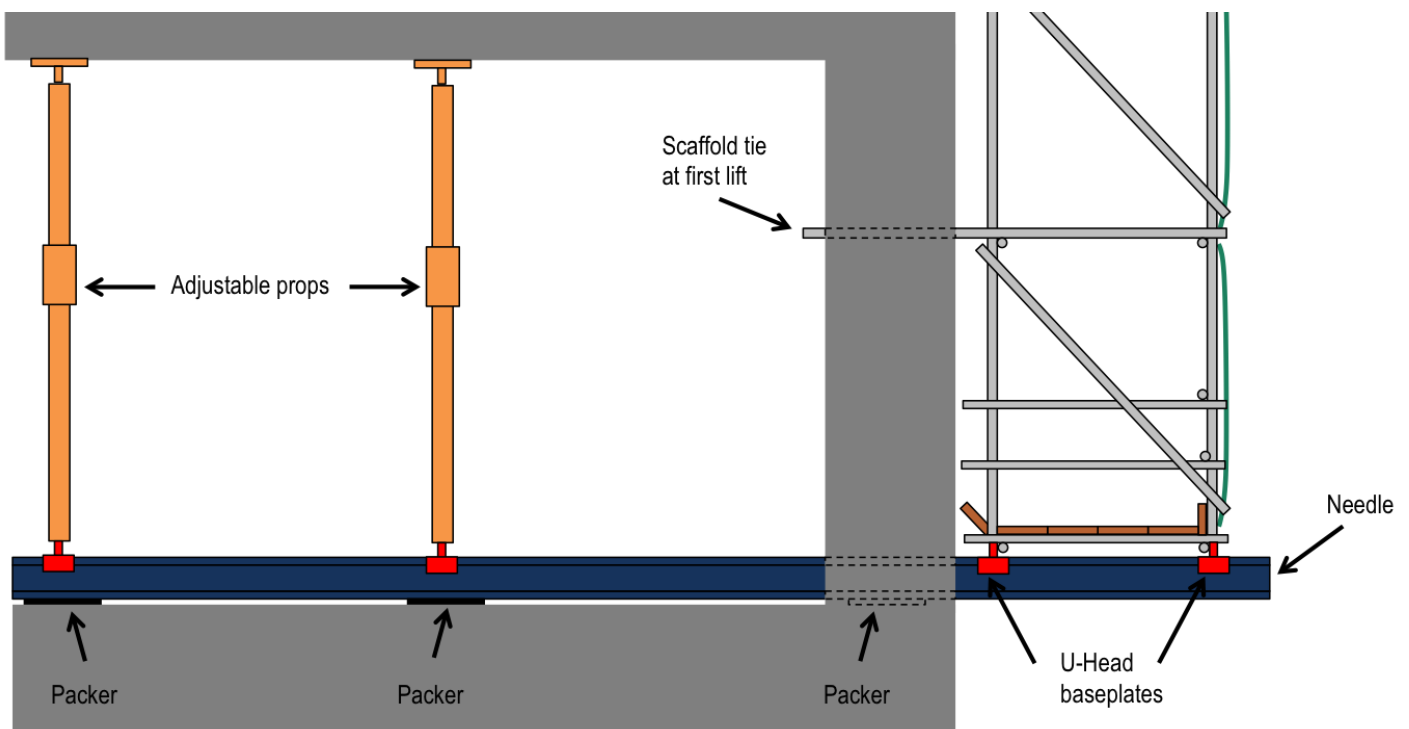

## Counterweights

All counterweights must meet the following requirements:

Item	Requirements
Counterweights	<ul style="list-style-type: none"> <li>▶ Only use counterweight specially designed, manufactured and approved for the erection of suspended scaffolds.</li> <li>▶ <b>Never use containers filled with sand or liquid for counterweights.</b></li> <li>▶ The counterweight should be secured directly on the needle or innermost support in such a way that they cannot be removed or displaced without the use of tools. This will help to prevent the counterweights from slipping from the scaffold or being removed by accident.</li> </ul>

## Stability for Cantilevered Needles

The ratio of stability of a cantilevered scaffold incorporating cantilevered needles must be not less than three, where the ratio of stability is the sum of the moments acting on the inboard portion of the needles divided by the sum of the moments acting on the outboard portion of the rig (3 inboard:1 outboard Ratio).

## Needles

You should ensure that the needles are adequate for the scaffold. Requirements you should check for include:

Item	Requirements
Needle or Supporting Beam	<ul style="list-style-type: none"> <li>▶ Must remain rigid and stable under working conditions.</li> <li>▶ The design should consider all forces and load (e.g. wind loads).</li> <li>▶ A reveal propped needle suspension rig: <ul style="list-style-type: none"> <li>◆ Should have at least two rows of uprights fixed with ledgers and transoms as well as longitudinal, transverse and plan bracing systems.</li> <li>◆ Needles can be fixed onto or under the reveal props.</li> <li>◆ Close fitting U-heads may be used with rolled steel joists or universal beams.</li> </ul> </li> <li>▶ Should always be mounted with the greater vertical dimension.</li> <li>▶ The outboard end of a needle should never be lower than the inboard end.</li> <li>▶ A beam spanning between only two supports should always be horizontal.</li> </ul>
Anchors	<ul style="list-style-type: none"> <li>▶ If anchorage bolts are used, they should be kept from loosening (e.g. with lock nuts).</li> <li>▶ Do not use friction or chemical insert anchors on needles.</li> <li>▶ Through bolts, props or bracket bolts are recommended for fixing the needles in place.</li> </ul>
Props	<ul style="list-style-type: none"> <li>▶ If using props, they should be installed to the top of the needle and to the underside of the floor above.</li> <li>▶ You must make sure that the props are correctly fixed to stop any movement or dislodgement: <ul style="list-style-type: none"> <li>◆ Have a competent person (such as an engineer) check that the floor is able to withstand the force of the props and scaffold.</li> </ul> </li> </ul>

## Cantilevered Crane Loading Platforms (CCLP)

CCLP's are used mainly on high-rise buildings to place and remove material from each floor. They are manufactured from steel and range in size and load capacity. CCLP's must be designed to comply with all relevant standards and have safe working loads stamped where crane crews can locate it easily.

CCLP's are normally secured by using Acro props which are tied together by tube and couplers.

**All props must be secured by tying scaffold tube with 90° coupler.**

**A single plan brace should be used to prevent twisting due to vibration and floor loading.**

**Acro props must be checked daily before any material is loaded on the loading bay. Acro props can loosen due to loading and unloading of floors, so it is imperative that the propping system securing the load is checked, by a competent person. i.e. an intermediate scaffolder.**

Cantilevered crane-loading platforms (CCLPs) are temporary platforms, which are often used during the construction or demolition of multi-storey buildings and structures so that materials and equipment can be shifted to or from floor levels.

The platform is generally cantilevered from the face of the building to allow loads to be directly raised or lowered by tower cranes or mobile cranes.

CCLPs can also be used for other purposes such as catch platforms to contain falling debris at the building perimeter and as supporting structures for scaffolds constructed at the building perimeter. They are sometimes set-up in a simply-supported mode such as over penetrations or voids, for use as loading platforms, access platforms or protection decks.

CCLPs are available in a variety of designs including fully fabricated and demountable types. They may have either fixed platforms or rolling platforms. **Their needles can be anchored to the supporting structure in several ways, such as through-bolting, bolting into cast-in inserts, or reveal-propping.** Reveal props may be purpose-designed, integral components or they may be general-purpose adjustable building props laced together with scaffold tubes and couplers.

**When any type of drilled-in anchors, self-drilling anchors, drop-in impact anchors or chemical anchors are used or the weight bearing capacity needs to be determined seek advice from a competent person, such as an engineer.**



## Installing A Cantilevered Crane Loading Platform

Cantilevered crane loading platforms (CCLP) should be installed in accordance with procedures and the supplier's or manufacturer's specifications and recommendations for that particular model.

CCLPs need to be braced and secured into place. There are two common methods for doing this:

- 1 Anchoring the needles supporting the CCPL into place using bolts through the needle and the structure it is placed on.
- 2 Using props that are secured at the roof and base to prevent the platform from shifting laterally (up and down) under load.

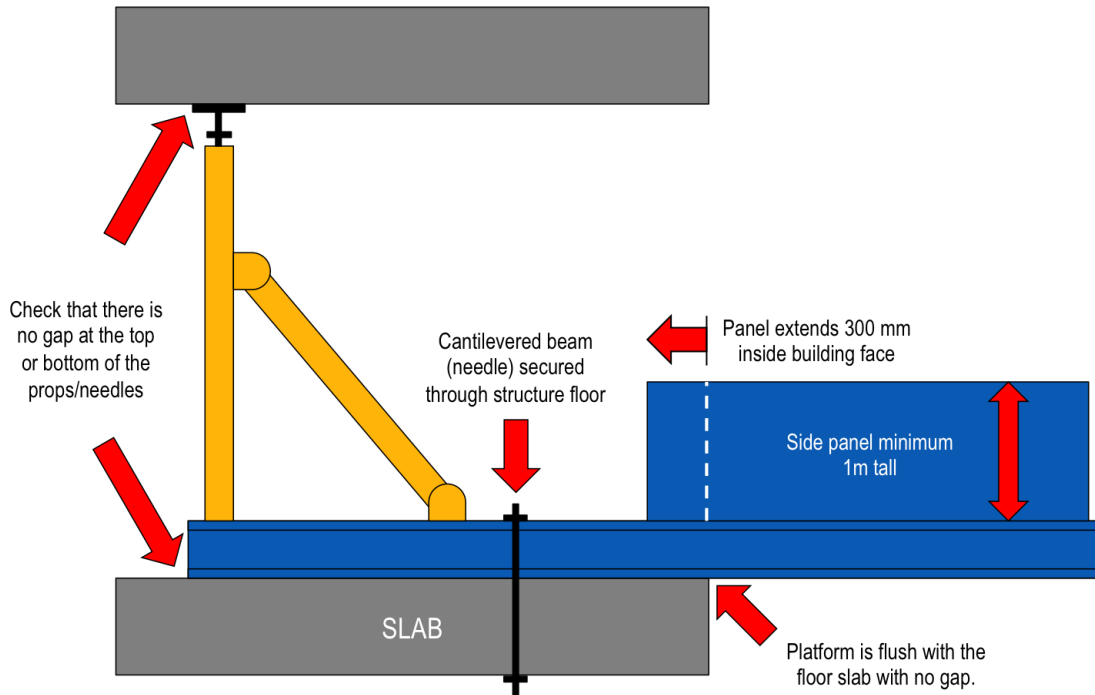

In some circumstances it may be necessary to use both methods at the same time.

Once in position the platform should be flush with the floor. If this is not possible you may fit ramps to the platform to assist with the transfer of materials.

Solid panels not less than 1m high should be fitted to the sides of the landing and extend at least 300mm inside the building's face.

Platforms facing a public roadway should not extend beyond the line of the overhead protection provided for the public.

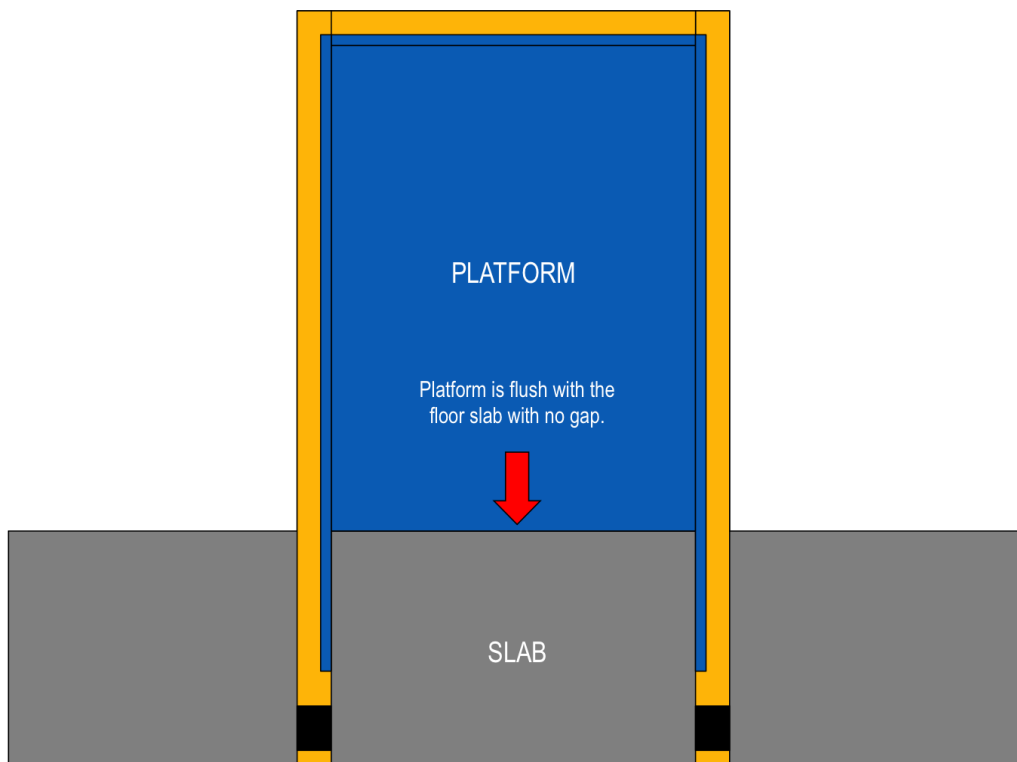

## Relocating a Cantilevered Crane Loading Platform

Relocation of a CCLP must be carefully planned out. Before the CCLP is moved you must make sure the areas where the platform is being moved from and to are be barricaded to prevent unauthorised people entering the area.

The area below the CCLP should also be barricaded and spotters used if necessary.

Fall arrest equipment must be in place where the relocation of the CCLP results in an unprotected edge, before the CCLP is moved.

All personnel/workers must use a static line with fall arrest harness and lanyard. If possible, edge protection should be installed as soon as the CCLP is removed.

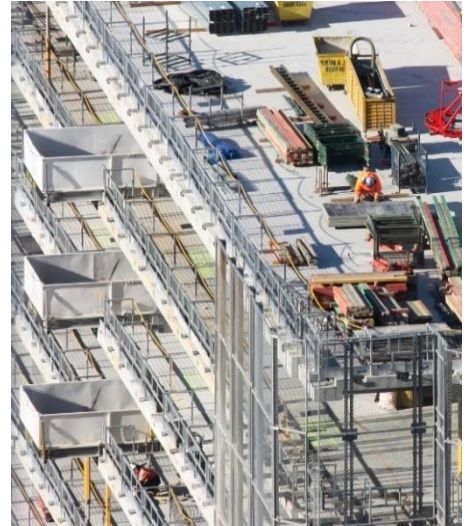

### STEPS

- ▶ The floor area where the platform is to be moved to, and the floor area where the platform is to be from, should be barricaded, fencing or guard rails installed to prevent unauthorised person from entering into the area while the change is made.
- ▶ Perimeter fencing must be removed while the change is made.
- ▶ No person should work near the unfenced perimeter edge unless attached to the building by a safety harness.
- ▶ The area below the platform relocation must be barricaded and spotters provided where necessary.
- ▶ Clear all loose objects from the platform before the crane lifts the platform.
- ▶ Perimeter fencing (handrails) should be replaced immediately after moving the platform.
- ▶ All bolts must be placed back in the respective vacant holes when erecting or dismantling.
- ▶ The lifting position must be clearly marked with signs painted on the platforms.
- ▶ The lifting lugs to lift the platform should be engineer designed.
- ▶ Props must be correctly secured at the top and also at the base by bolting, welding, or other suitable securing method to stop any lateral displacement.
- ▶ The tare weight of the platform must be displayed on the platform.
- ▶ Some platforms have a rubbish bin inserted under the platform deck. The rubbish bin must be removed and emptied before the platform is shifted.
- ▶ A waterproof sheet with instructions should be attached to the platform showing all operational and safety instructions of how to use and lift the platform.

### USE

Before the platform can be used:

- ▶ All bolts or connectors must be secured and tightened in position.
- ▶ All props must be plumb and have the rear ties in position.
- ▶ Adjustable props must be adjusted to ensure minimal adjustable jack extension.
- ▶ Rear handrails must be in position.
- ▶ The side panels and gates must be positively fixed in position.
- ▶ Engineer approved

Gates must be closed at all times except for long loads. All platforms must be kept clean and clear of loose materials.

Platforms should only be used in the manner for which they were designed. Any alterations or different use of the platforms should be to an engineered design.

## Safe Use of a Cantilevered Crane Loading Platform

When using a cantilevered crane loading platform:

- ▶ Make sure the gates are closed at all times. They may be open when moving long loads.
- ▶ Keep all platforms clean and clear of loose materials or debris.
- ▶ Only use a cantilevered crane loading platform in the manner for which it was designed. Any alterations or different use of the platforms should be to an engineered design.

Rolling cantilevered crane loading platforms can be rolled in and out of a building. Make sure that braces, locking pins and spreader bars are in position and secured and that the tie bar at the rear of the platform is used at all times.

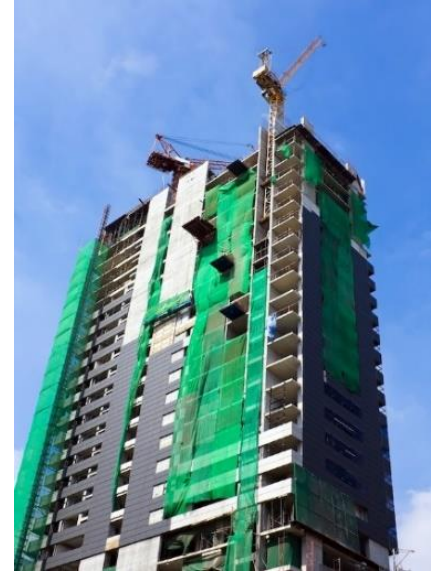

### The Platform



The platform needles should be secured against lateral displacement.

A minimum of two signs stating both the maximum uniformly distributed load and the maximum concentrated load that the platform can carry must be in clear view on the platform.

The platform decking should be flush with and abutting the floor slab, otherwise suitable ramps should be fitted.

There should not be any gap between the platform and the site handrails.

Platforms located on the side of a building facing a public roadway should not extend beyond the line of the overhead protection provided for the public.

### Certification

The installation and dismantling of CCLPs must be carried out by a person holding either the Basic Rigging or an Intermediate Scaffolding High Risk Licence.

Whenever a CCLP is located or removed by a crane, the slinging and load direction must be controlled by a person with a Dogging or Rigging High Risk Licence.

The propping of CCLPs with adjustable building props and scaffold tubes and couplers or other types of scaffolding equipment must be controlled by a person with an Intermediate Scaffolding High Risk Licence.



## Installing Perimeter Safety Screens and Shutters



Perimeter safety screens and shutters are designed to prevent personnel/workers and any debris, tools or materials falling from a height.

Perimeter safety screens generally extend one floor above the floor they are installed on.

The top of the screen should be high enough to provide edge protection for the floor that is to be built before any personnel/workers can gain access to it.

The framework supporting the screen needs to be able to bear the load of the screen.

The mesh needs to be of minimum gauge 2.5mm, and have a maximum mesh opening size of:

- ▶ 25mm nominal where no lining is used.
- ▶ 50mm nominal where lining is used.

Gaps between screens and between the screens and the structure should not exceed 25mm.

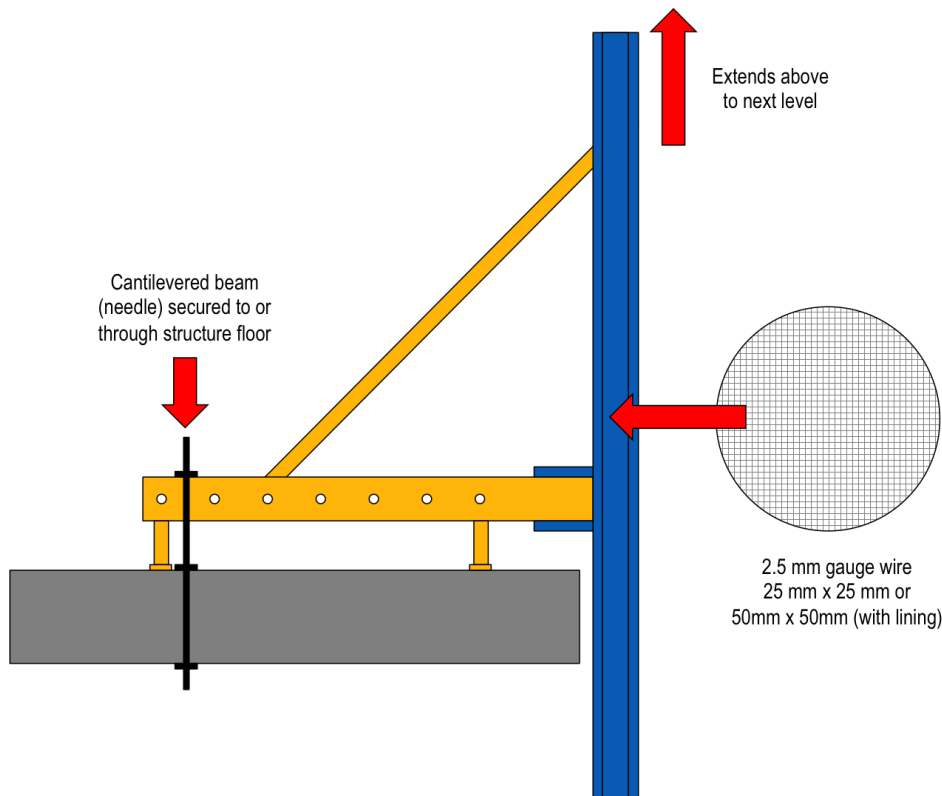

Perimeter safety screens may be installed using needles or props provided by the manufacturer and designed to be used with a specific safety screen system.

These should be secured adequately to support the weight of the screens.

There may be different options provided by manufacturers to secure any supporting structures to concrete or other structural members.

Always install the safety screen system in accordance with procedures and the manufacturer's specifications.

Always conduct work safely including the use of a fall-arrest system whenever working near an exposed edge during the installation or removal of safety screens and shutters.

Most high rise buildings use a safety screen to protect workers while working, these screens act as the perimeter scaffold and must comply with Regulation 117(12).

They must be designed to ensure all material is contained within the building and no material once dislodged can fall to the ground.

Perimeter safety screens must be designed to suit the particular building on which they are to be used.

Safety screens can be built by using steel solders or modular welded steel and can become a part of the formwork.

Each section must be fully meshed and have built in deflection or catchment platform on them to ensure material cannot fall.

The safety screens are secured in approved manner to ensure the safety of employers/ employees.

Each section is lifted into position by either a crane or in built hoisting mechanisms.

The safety screen once in position normally covers 3 floors.

Always install the safety screen system in accordance with procedures and the manufacturer's specifications.

Always conduct work safely including the use of a fall-arrest system whenever working near an exposed edge during the installation or removal of safety screens and shutters.

### Setting Up A Mast Climber

The base of the mast climber can be placed either with the mast outwards for a freestanding unit, or with the mast inwards where the mast is tied to the building.

Always make sure that the sequence of installation does not put any personnel/workers in any danger and that no part of the equipment is overstressed or overburdened.

The outriggers must be fully extended and locked (as per manufacturer's recommendations for the actual setup of the machine) before the erection process may begin.

Packing must be used depending on the ground conditions, and to ensure that the towers are level, plumb and aligned. Never setup the mast climber over a trench or excavation.

If the mast climber is being set up on a suspended concrete slab, make sure you get a certificate of compliance from an engineer first to determine that the floor can support the weight of the equipment.

A free-standing mast should not be used in high winds.

The mast must be anchored to the building at spacing determined by an engineer or the manufacturer.

The building must be checked to ensure that it can withstand the strain that may occur in high winds. If the building is not strong enough to withstand the force of the load, the anchor point should be lowered to a point where there is enough strength to provide enough support for the equipment.

Once the mast climber has been installed you will need to test all of the limit switches and erect appropriate fencing, barriers and gates to prevent unauthorised access to the area.

Signs displaying the working load limit (WLL) of the mast climber will need to be installed where they can be clearly seen by any personnel/workers authorised to use it.

Always check that the finished mast climber meets the design specifications provided by the manufacturer.



## Putlogs

Putlogs shall be provided to support platforms constructed from scaffold planks. Where putlogs are used instead of transoms, the following apply:

- ▶ Putlogs shall be fixed with putlog couplers or right-angle couplers
- ▶ Putlogs shall be horizontal
- ▶ Each putlog shall be fixed to the upper surface of each ledger it crosses with putlog couplers or right-angle couplers
- ▶ The types of couplers used in any one lift shall be compatible, so that putlogs provide true and even support for the scaffold planks
- ▶ Putlogs shall be fixed as not less than 150mm nor more than 250mm from each side of each standard
- ▶ Putlogs may cantilever towards the working face to support additional scaffold planks, provided that:
  - ◆ The width of the additional platform does not exceed 450mm (unsupported)
  - ◆ The transverse standard spacing is not less than 950mm, and
  - ◆ The putlogs are fixed to ledgers with right-angle couplers
- ▶ Putlogs shall be full-length tubes, without any joints over their length
- ▶ Additional intermediate putlogs shall be provided to comply with the following:
  - ◆ Putlog Spacings
    - The maximum spacing used between Putlogs supporting **32mm thickness solid timber scaffold planks is 1m.**
    - The maximum spacing used between Putlogs supporting **38mm thickness solid timber scaffold planks is 1.5m.**
    - The maximum spacing used between Putlogs supporting **50mm thickness solid timber scaffold planks is 2m.**
    - The maximum spacing used between Putlogs supporting **63mm thickness solid timber scaffold planks is 2.5m.**
  - Each plank shall overhang its end putlog by a minimum of **150mm and no more than 250mm.**

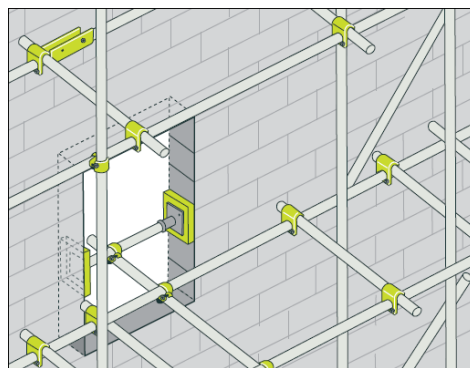

- ◆ Where it is necessary to lap planks, the overlapping plank shall extend past the putlog by no less than 150mm
- ◆ Planks less than 3m in length shall be positively secured against an end being lifted by a downward force on the other end
- ◆ The loading shall not exceed the designated duty loading of the scaffold
- ◆ Additional planks may be supported by that portion of putlogs cantilevered towards the working face, provided that the outermost plank is secured against displacement and the platform does not exceed light duty, irrespective of the duty of the adjacent working platform

## Toe boards

Toe boards shall be securely fixed to the inside of the standards and, where a toeboard or kickplate is not provided adjacent to the working face of a building or structure, the gap between the platform edge and face should be less than 225mm. A safeguard to prevent anyone being endangered by debris falling from the platform should also be installed.

Where necessary, cantilevered catch platforms should be provided to prevent unintended spillages from falling to the ground.

## Catch Platforms

A catch platform shall satisfy the following requirements:

- ▶ The cantilevered portion of the platform shall be at an angle sufficient for the intended task
- ▶ The platform shall be closely decked to prevent materials falling through
- ▶ The minimum dimensions shall be sufficient for the intended task
- ▶ The scaffold design shall be such that debris expected to be caught on a catch platform shall not destabilise the scaffold
- ▶ The platform decking shall not be capable of dislodgement under environmental or working conditions
- ▶ The platform shall be constructed to contain falling material. A catch platform shall not be used as an accessway
- ▶ If persons are required to access catch platforms, edge protection shall be provided

## Access and Egress

Every working platform must have safe and suitable access and egress.

Common means of access and egress include existing floor levels, permanently installed platforms, ramps, stairways, ladders, personnel hoists, temporary access ways, temporary stair systems and portable ladders.

The form of access and egress for working platforms on a scaffold depends upon the nature of the work, the site conditions and restrictions, the height of the platforms, the number of people required for the work and the time the scaffold will be standing.

Where access is provided by mechanical means, such as a personnel hoist, an alternative form of egress, such as a ladder or stair tower should also be provided for emergency use.

## Standards

Standards shall:

- ▶ Be founded on baseplates
- ▶ Be vertical
- ▶ Extend to the full height of the scaffold
- ▶ Be spaced to comply with the relevant duties required
- ▶ Be joined with end-to-end couplers, and
- ▶ Not have joints that occur
  - ◆ In longitudinally or transversely adjacent standards in the same list
  - ◆ In the same standard in adjacent lifts
  - ◆ More than once between adjacent ledgers, or
  - ◆ More than 300mm from a ledger

Where standards are likely to be damaged in any way, they shall be provided with suitable guards or fenders or double standards. A foot tie shall be provided where there is likelihood of movement of the bottom of a standard.

The maximum lift height for an independent scaffold is 2 meters. However, if constructing a gantry or covered way, a first lift height of 3 meters can be applied only when double standards are installed.

Height of Scaffold	Steel Tube	Aluminium Tube
24 ≤ 33	2	1
16 ≤ 24	3	2
8 ≤ 16	4	3

## Ledgers, Joints and Transoms

### Ledgers

Ledgers shall:

- ▶ Be fixed to each standard in a longitudinal row with right-angle couplers;
- ▶ Be horizontal; and
- ▶ Extend for the full length of the scaffold.

The distance between the surface supporting a standard and the first ledger, and the distance between vertically adjacent ledgers, shall be not more than 2m.

NOTE: Consideration should be given to the inclusion of a base lift in some circumstances, such as high scaffolding, scaffolding erected on sloping ground, and scaffolding erected on a low-resistance surface.

### Joints

Joints shall be made with sleeve type end-to-end couplers. Joints shall not be located:

- ▶ In horizontally or vertically adjacent ledgers in the same bay;
- ▶ In the same ledger adjacent bays;
- ▶ More than once between adjacent standards;
- ▶ In the end bays of a scaffold; or
- ▶ More than 300mm from a standard.

NOTE: Internal joint pins used in tubes of different wall thicknesses or in tubes produced by the ERW process are incapable of resisting tensile forces in the joint.

### Transoms

Where transoms are used to fix transverse standards, they shall be:

- ▶ Full length tubes without joints;
- ▶ Horizontal;
- ▶ Fixed to each standard with right-angle couplers; and
- ▶ Fixed as closely as possible to the node point of each ledger and standard.

## Inspection and Maintenance of Scaffolds

Once the scaffold has been erected it will need to be inspected by a competent person for the following:

- ▶ Stability and condition of structure.
- ▶ Standards secure, plumb, correctly and spaced to meet the load/duty requirements.
- ▶ Ledgers secure, level, correctly spaced (where relevant).
- ▶ Transoms/putlogs secure, level, correctly joined and spaced (where relevant).
- ▶ Bracing and ties in correct position and properly fixed (where relevant).
- ▶ Sufficient and safe access to all working platforms.
- ▶ Platforms positioned and secured correctly. Correct number and dimensions of platforms for duty.
- ▶ Edge protection correctly installed.
- ▶ Sheeting/screens/shutters correctly installed (where relevant).
- ▶ Scaffold matches structural plan.

Once a scaffold erection, inspection or modification is completed, a licenced scaffolder needs to place an inspection record on the scaffold.

The inspection record needs to include the following details:

Record Detail	Explanation
Location	Unit/ plant number followed by area of plant.
Ref. No.	Work Order number.
Date Erected	Date the erection of the scaffold was complete.
Requested By	This should be the Team leader/ Plant Area Coordinator etc., requesting the scaffold. (This may be on the Work Order).
Built By	This is the company who built the scaffold.
Name of Competent Person	Print the name of the competent person/certified scaffolder.
Signature	Signature of competent person/certified scaffolder.
Light Duty 225kg	As per AS/ NZS 4576.
Medium Duty 450kg	
Heavy Duty 675kg	

## Modifying or Inspecting a Scaffold

Where practicable, the licensed person who erected the scaffold, and whose name appears on the inspection record, is to be the person to perform scaffold modifications and inspections.

Prior to modifying scaffold:

- ▶ Remove the inspection record.
- ▶ Replace with a notification inspection record detailing the date and time of the modification or inspection, the name of the person performing the modification or inspection and the reason for the alteration where relevant.

Shown here is an example of an inspection record system of cards:



## Completing a Handover Certificate

As the licensed person who erected the scaffold, you will need to complete a handover certificate and sign off tag when the job is complete.

It should contain the following information:

- ▶ The name of the client that the work has been done for.
- ▶ Address of the worksite where the tasks were completed.
- ▶ The location of the scaffold in the worksite.
- ▶ The type of scaffold that was erected (e.g. modular, mobile).
- ▶ The height and length of the scaffold.
- ▶ The number of lifts and bays in the scaffold.
- ▶ The duty category of the scaffold (e.g. light, medium, heavy, special).
- ▶ The type of access available (e.g. ladder, ramp, stairway).
- ▶ Design reference number.
- ▶ Date and time of handover.
- ▶ Name and signature of the responsible person.

## Accidents and Incidents

### Incidents Relating to the Use of Fall Arrest Systems

If a worker who is using an individual fall-arrest system falls from an edge, the system may act as a pendulum.

This may result in the worker hitting the ground (called 'swing down') or swinging back into the building or structure (called 'swing back').

These situations may also be referred to as 'the pendulum effect'.

Swing down can occur if the lanyard slides back along the perimeter edge of the roof as a worker falls, until it is vertical.

When this happens, the worker may hit the ground (or lower level), or the lanyard may break from being dragged across the edge of the roof.



### Suspension Trauma

Suspension trauma can occur with a fall arrest system when a person has an arrested fall and is suspended in an upright, vertical position with the harness straps causing pressure on the leg veins/femoral arteries.

The lower legs' capacity to store large amounts of blood reduces the return of blood to the heart, slowing the heart rate, which can cause the person to faint.

This may lead to renal failure and eventually death, depending on a person's susceptibility. This condition may be worsened by heat and dehydration.

### Preventing Suspension Trauma

The following techniques can be used to help prevent suspension trauma in a person who is hanging in a fall arrest harness:

- ▶ Never work alone when using a harness as fall protection.
- ▶ Wherever possible use a fall arrest harness that allows the legs to be kept horizontal.
- ▶ If possible keep the time a worker spends in suspension after a fall limited to less than five minutes. This can be achieved by providing foothold straps or a way of placing weight on the legs.

If you find yourself in a situation where you are suspended in a fall-arrest harness after a fall attempt the following action:

3. Move your legs in the harness and push against any footholds to relieve pressure on your upper legs.
4. Move your legs as high as possible and tilt back so that you become as horizontal as possible.

The quick rescue of a person suspended in a full body harness, as soon as possible, is vital.



For this reason, workers should be capable of conducting a rescue of a fallen worker and be familiar with onsite rescue equipment and procedures.

If a worker has fallen and is hanging suspended in a safety harness for a prolonged period of time (5 to 30 minutes) it is absolutely vital that first aid procedures are implemented as quickly as possible.

### First Aid for Suspension Trauma

In accordance with Australian Resuscitation Council (ARC) guideline 9.1.5, first aid management of suspension trauma should be carried out as follows:

1. Call for an ambulance (dial 000 or 112).
2. If unconscious, manage the victim according to basic life support principles. If conscious, rest the victim in a comfortable position, ideally lying down, and provide reassurance.
3. Loosen or remove the harness.
4. Administer oxygen if available.
5. Look for and manage associated injuries in the victim, especially if they have fallen or been electrocuted.
6. Monitor the signs of life at frequent intervals.

Remember, care of the airway takes precedence over any injury.

## Conclude Scaffolding Operations

### Tidy the Work Area

Once the work has been completed you need to clean up the work area. Remove any leftover materials and debris created by the task as soon as practicable.

Litter and other building debris can cause a tripping hazard for personnel. Make sure all rubbish is collected and disposed of correctly.

Dispose of any debris properly without impacting negatively on the environment. Make sure all materials are collected and removed properly.

Divide up recycling and other waste materials for correct removal and processing.

Inspect and Store All Scaffolding Equipment

All equipment needs to be inspected once all scaffolding operations have been completed. Check for any damage that may have occurred while the equipment was in use.

The manufacturer's instructions may have inspection checklists relating to different types of equipment that should be referred to.

Make sure that you clean the equipment if necessary and that all scaffolding equipment and parts are stored correctly in accordance with site procedures.

### Isolate Faulty Equipment and Report Defects

Any defective equipment needs to be properly isolated and removed from service to prevent anybody from accidentally using it and standard procedures for isolating equipment and recording and reporting defects need to be followed.

### Remove Hazard Control Measures

Any control hazards that are no longer required need to be removed from the work area and stored according to procedures.

Inform any relevant personnel that the work area has been returned to normal conditions and that your tasks have been completed.

## Appendix A – Occupational/Work Health & Safety Common Terms and Definitions

<b>Person Conducting a Business or Undertaking (PCBU)</b>	<p>A 'person conducting a business or undertaking' (PCBU) replaces the term 'employer'. A PCBU includes all employers, sole traders, principal contractors, unincorporated associations, partnerships and franchisees. Volunteer organisations that also employ people will be PCBUs.</p> <p>A PCBU's primary duty of care is to ensure the health and safety of everyone in the workplace, so far as is reasonably practicable.</p>
<b>Officers</b>	<p>An 'Officer' is a person who makes, or participates in making, decisions that affect the whole or a substantial part of a corporation. This includes Health and Safety Representatives (HSR).</p>
<b>Workers</b>	<p>'Worker' replaces the term 'employee'. It is defined broadly to mean a person who carries out work in any capacity for a PCBU.</p> <p>A 'worker' covers employees, contractors, sub-contractors (and their employees), labour hire employees, outworkers, apprentices, trainees, work experience students and volunteers.</p>
<b>Reasonably Practicable</b>	<p>Reasonably Practicable is defined as action that is, or was at a particular time, reasonably able to be done to help ensure health and safety based on the following factors:</p> <ol style="list-style-type: none"> <li>a) Chances of the hazard or risk occurring (likelihood).</li> <li>b) The degree of harm (consequence).</li> <li>c) The knowledge of persons involved in the situation relating to the hazard or risk and methods of eliminating or controlling it.</li> <li>d) The availability and suitability of ways to eliminate or control the hazard or risk.</li> <li>e) The costs involved in taking action to eliminate or control the hazard or risk including consideration of whether the cost involved is inconsistent to the level of risk.</li> </ol>
<b>Due Diligence</b>	<p>The Work Health and Safety Act 2011 (the WHS Act 2011) imposes a specific duty on officers of corporations to exercise due diligence to ensure that the corporation meets its work health and safety obligations. In short, they have a responsibility to ensure that the PCBU is doing everything it should to ensure health and safety.</p> <p>The duty requires officers to be proactive in ensuring that the corporation complies with its duty.</p> <p>Due diligence may be demonstrated through the following courses of action:</p> <ol style="list-style-type: none"> <li>1. Acquiring knowledge of health and safety issues.</li> <li>2. Understanding operations and associated hazards and risks.</li> <li>3. Ensuring that appropriate resources and processes are used to eliminate or minimise risks to health and safety.</li> <li>4. Implementing processes for receiving and responding to information about incidents, hazards and risks.</li> <li>5. Establishing and maintaining compliance processes.</li> <li>6. Verifying the provision and use of the resources mentioned in 1-5.</li> </ol>

## Appendix B – Scaffolding Common Terms and Definitions

Term	Definition
Access platform	A platform that gives access to and from places of work to persons, materials and equipment
Accessory	A fitting that is able to be attached to a structural member of a scaffold, or to join a structural member to something else
Baseplate	A plate that is able to distribute the load from a load-bearing member to a supporting structure
Bay	The space enclosed by four adjacent standards, or the equivalent space in a single-pole scaffold
Bay length	The horizontal distance between any two longitudinally-adjacent standards in an independent scaffold or a single-pole scaffold, or the horizontal distance between any two longitudinally-adjacent support points on the cradle of a suspended scaffold.
Bay width	The horizontal distance between any two transversely-adjacent standards in an independent scaffold, or the horizontal distance between a standard and a transversely-adjacent wall in a single pole scaffold, or the width of the cradle of a suspended scaffold
Beam clamp	A fitting that is able to secure a sling or chain to the underside of a universal beam, rolled steel joist, tapered flange beam or similar
Birdcage scaffold	An independent scaffold consisting of more than two rows of standards connected by ledgers and transoms
Box tie	A tie assembly that is positively fixed to every side of a column or beam
Brace	A member fixed diagonally to two or more members of a scaffold, to provide rigidity to the scaffold
Bricklayers scaffold	A single-pole scaffold
Bridle	A horizontal member spanning between putlogs or transoms, for the purpose of supporting intermediate putlogs
Cantilevered scaffold	A scaffold that is supported by cantilevered load-bearing members
Cantilevered builders' hoist	A builders' hoist where the car, bucket or platform is cantilevered from, and travels up and down externally to a face of, the support structure
Castor	A swivelling wheel attached to the lower end of a standard, for the purpose of supporting and moving a scaffold
Catch platform	A platform, attached to a scaffold, to contain falling debris
Check coupler	A right-angle coupler that is fixed hard against a load-bearing coupler, to restrict or prevent slippage of that coupler along the tube
Chord	A principal longitudinal member of a scaffold beam or truss
Competent person	A person suitably qualified, adequately trained and appropriately experienced for the particular class or kind of work described
Counterweight	A weight or series of weights that counterbalance a scaffold against overturning

Term	Definition
Coupler	A fitting that joins two tubes
Double coupler	A right-angle coupler
End-to-end coupler	A coupler for joining two tubes end-to-end
False standard	A puncheon
Fan	A cantilevered catch platform
Flange/Beam clamp	A load-bearing clamp (rigid or swivelling) for connecting a tube to the flange of a structural member
Fork head	A u-shaped housing (fixed or adjustable) for supporting and locating a standard over a bearer or a bearer over a standard
Freestanding scaffold	A scaffold that is not attached to any other structure and is stable against overturning, on its own account or if necessary assisted by stabilisers, outriggers, counterweights or backup bays (buttress bays)
Fulcrum point	The point of pivot nearest to the outside edge of a cantilevered scaffold which the balancing moments of a cantilevered scaffold are calculated
Gantry	A structure, constructed from structural steel, scaffolding or structural timber, that is primarily intended to support a protection deck or portable buildings such as amenity shed
Guardrail	A structural member to prevent persons from falling off any platform, walkway, stairway or landing
Height of a scaffold	The vertical distance from the supporting structure to the highest working platform of the scaffold
Inboard portion of a cantilevered scaffold	The portion of a cantilevered scaffold that is on the inside of the fulcrum point
Independent scaffold	A scaffold consisting of two or more rows of standards connected together longitudinally and transversely
Internal-perimeter scaffold	A scaffold erected alongside the inside perimeter of a penetration or shaft in a building or other structure
Joint pin	An internal end-to-end coupler for joining two tubes
Keeper/safety clip	A check coupler
Kickboard	A toeboard
Ladder	An appliance on which a person may ascend or descend, consisting of two stiles joined at regular intervals by cross-pieces (e.g. cleats, rungs, steps, treads)
Ladder beam	A scaffold beam with chord stiffeners at right angles to the chords
Ledger	A horizontal structural member that longitudinally spans a scaffold
Lift	The vertical distance from the supporting surface to the lowest ledger of a scaffold or level at which a platform can be constructed. Also, the vertical distance between adjacent ledgers or levels of a scaffold at which a platform can be constructed
Loading bay	A platform on a scaffold for the storage of materials and equipment

Term	Definition
Longitudinal brace	A brace in a vertical plane on the face of a scaffold
Mast climber	Mast-climbing work platform
Mast-climbing work platform	A work platform used for temporary purposes to raise personnel and materials to a working position by means such as a rack-and-pinion drive mounted on an extendible mast, which may be tied to a building
Midrail	A member fixed parallel to and above a platform, between the guardrail and the platform and/or kickboard
Mobile scaffold	An independent free-standing scaffold that is mounted on castors
Needle	A cantilevered structural member that supports a scaffold
Ninety-degree coupler	A right-angle coupler
Node point	A fixed junction between a ledger or transom and a standard
Outboard portion of a cantilevered scaffold	The portion of a cantilevered scaffold that is on the outside of the fulcrum point
Outrigger	A framed component that increases the effective base dimensions of a tower and is attached to the vertical load-bearing members
Panel	The area enclosed by two longitudinally adjacent standards and two vertically adjacent ledgers or levels of a scaffold at which a platform could be constructed
Plan brace	A brace in the horizontal plane that is attached to vertical load-bearing members
Platform	An elevated surface
Puncheon	A vertical supporting member supported from another structural member of a scaffold
Putlog	A horizontal structural member, spanning between ledgers or between a ledger and an adjacent wall, that is intended to support a platform
Putlog blade	A fitting fixed to the end of a putlog, so that the putlog may be located and supported in a joint of a wall
Putlog coupler	A coupler for fixing a putlog to a ledger
Putlog scaffold	A single-pole scaffold
Raker	An inclined tube fixed to a scaffold to keep the scaffold stable
Return	A part of a scaffold set up around the corner of a building or structure
Reveal	Internal side surfaces of an opening or recess
Reveal prop	A vertical member that is able to support a needle or other cantilever member. A common example would be an adjustable building prop that is usually tightened between the adjacent floors of a building or other structure
Reveal tie	An assembly, consisting of a reveal tube, pin, wedge or secure fitting and pads, that is fixed in a reveal, together with any tie tubes

Term	Definition
Right-angle coupler	A non-swivel load-bearing coupler, other than a putlog coupler, for connecting two tubes at right angles
Scaffold	A temporary structure for supporting access platforms or working platforms (see also definitions for birdcage scaffold, cantilever scaffold, freestanding scaffold, hung scaffold, independent scaffold, mobile scaffold, putlog scaffold, single-pole scaffold, spur scaffold, suspended scaffold and tower scaffold)
Scaffold beam	A fabricated member consisting of two or more chords and a number of stiffeners between the chords (e.g. a ladder beam, a unit beam)
Scaffold plank	A decking component, other than a prefabricated platform, that is able to be used in the construction of a platform supported by a scaffold
Scaffolder	A person engaged in erecting, altering or dismantling scaffolding
Scaffolding equipment	Any component, assembly or machine used or intended to be used for the construction of scaffolding
Single coupler	A putlog coupler
Single-pole scaffold	A scaffold consisting of a single row of standards that are connected together by ledgers and putlogs fixed to ledgers and built into the wall of a building or structure
Sleeve coupler or external joiner	An external end-to-end coupler
Soleplate	A member used to distribute a load through a baseplate to the ground or other supporting structure
Spur	An inclined load-bearing member that transmits a load to a supporting structure
Spur scaffold	A scaffold that is partially supported by inclined load-bearing members
Stanchion	A vertical member used to support a guardrail, a mesh panel or similar
Standard	A vertical structural member that transmits a load to a supporting structure
Swivel coupler	A coupler for connecting two tubes at any angle
Through tie	A tie assembly that is positively fixed to both sides of an opening through a building or structure
Tie	A member or assembly of members used to tie a scaffold to a supporting structure
Toeboard	A scaffold plank or purpose-designed component fixed on edge at the edge of a platform, to prevent material falling from the platform
Toeboard clip	A fitting used to secure a toeboard to a standard or stanchion
Tower scaffold	A scaffold of one bay
Transom	A horizontal structural member transversely spanning an independent scaffold between standards
Transverse brace	A brace in a plane that is vertical and at right angles to the building or structure

Term	Definition
Tube-and-coupler covered way	An independent tube-and-coupler scaffold that is primarily intended to provide overhead protection
Tube-and-coupler scaffolding	A scaffold of which the standards, ledgers, braces and ties are circular tubers that are joined together by means of purpose-designed couplers
U-head	A fork head
Working load limit (WLL)	The maximum working load that may be applied to any component or system, under general conditions of use
Working platform	A platform that is intended to support persons, materials and equipment
Yoke tie	A box tie

## Appendix C – Referenced Documents Information

The following documents are referred to in the Standards (AS/NZS 1576 Parts 1-6):

### AS

- ▶ 1576 Scaffolding
- ▶ 1576.2 Part 2: Couplers and accessories
- ▶ 1577 Scaffold planks
- ▶ 1892 Portable ladders
- ▶ 1892.2 Part 2: Timber

### AS/NZS

- ▶ 1576 Scaffolding
- ▶ 1576.1 Part 1: General requirements
- ▶ 1576.3 Part 3: Prefabricated and tube-and-coupler scaffolding
- ▶ 1892 Portable ladders
- ▶ 1892.1 Part1: Metal
- ▶ 2269 Plywood – Structural
- ▶ 4576 Guidelines for scaffolding

### NZS

- ▶ 3609 Specification for timber ladders
- ▶ 3620 Scaffold planks

## Appendix D – Excerpts from the Standards

### Scaffold Basic Level

AS/NZS 1576.6:2000

2

#### PREFACE

This Standard was prepared by the Joint Standards Australia/Standards New Zealand Committee BD/36, Scaffolding, to supersede AS 1576.3 Supp 1—1991, *Scaffolding, Prefabricated and tube-and-coupler scaffolding, Metal tube-and-coupler scaffolding—Deemed to comply* (Supplement to AS 1576.3—1991).

This Standard is intended to simplify the application of AS/NZS 1576.3 for commonly designed scaffolding.

This edition includes the following technical changes from the previous edition:

- (a) The height of scaffolding that is covered, as specified by the Scope, has been reduced from 45 m to 33 m.
- (b) Requirements for access openings, platform brackets and cantilevered catch platforms (fans), each of which contain requirements that imply the need for an engineering design, have been deleted.
- (c) Some definitions that are surplus to its needs have been deleted.
- (d) The requirements for birdcage scaffolds have been revised.

The Standard is issued as Part 6 to the AS/NZS 1576 series of Standards, so that it will not be made redundant when Part 3 is next revised, as happened when it was designated as a Supplement to Part 3.

## SECTION 7 MATERIALS

### 7.1 COMPLIANCE WITH STANDARDS

The first step in the process of safely erecting and using scaffolding is to carefully select the correct scaffolding equipment for the particular job.

When ordering equipment for scaffolding, the buyer should specify that the equipment is intended to be used for the construction of a scaffold. New or unused scaffolding equipment should comply with any relevant Standards that are listed in Table 7.1.

Upon request, the supplier of any equipment should provide a statement that the equipment has been designed, manufactured and, where relevant, tested and marked in compliance with the requirements of any relevant Standards that are listed in Table 7.1. If the equipment is not new, the supplier should also provide a statement that the equipment, when new, complied with the relevant Standards that are listed in Table 7.1 at the time of its manufacture and also that, as supplied, it is in a fit and serviceable condition.

Suppliers of scaffolding equipment should provide adequate information that will enable the equipment to be used according to design specifications. The information should include guidance for the servicing and inspection of the equipment and the rejection of faulty equipment.

**TABLE 7.1**  
**STANDARDS FOR SCAFFOLDING EQUIPMENT**

Type of equipment	Standard
Boatswain's chair seats	AS/NZS 1576.1
Chain	AS 2321, NZS/ISO 1835,
Cradles	AS 1576.4, AS/NZS 1576.1
Eyebolts	AS 2317, NZS/BS 4278
Fibre ropes	AS 4142.2, NZS/BS 2052
Plywood	AS/NZS 2269
Portable ladders—metal	AS 1892.1, NZS 5233
Portable ladders—timber	AS 1892.2, NZS 3609
Prefabricated platform units	AS/NZS 1576.3
Prefabricated scaffold components	AS/NZS 1576.3
Rigging screws and turnbuckles	AS 2319, NZS/BS 4429
Scaffold accessories	AS 1576.2
Scaffold couplers	AS 1576.2
Scaffold planks	AS 1577, NZS 3620
Scaffold tubes	AS/NZS 1576.3
Scaffolding hoists	AS 1418.2
Scaffolding hoist protective devices	AS 1576.4
Shackles	AS 2741, NZS/BS 3551
Sheave blocks	AS 2089
Slings—chain	AS 3775
Slings—fibre rope	AS 1380
Slings—flat synthetic-webbing	AS 1353.1
Slings—wire coil flat	AS 1438
Slings—wire rope	AS 1666, NZS/ISO 7531
Splitheads	AS/NZS 1576.5
Stairways—temporary	AS/NZS 1576.1
Steel wire ropes	AS 3569, NZS/BS 302.2
Thimbles for fibre rope	NZS 1583
Thimbles for wire rope	AS 1138
Trestles (other than trestle ladders)	AS/NZS 1576.5
Wire rope grips (bulldog grips)	AS 2076

## Scaffold Intermediate Level

### 8.7 WORKING PLATFORMS

Each scaffold should be designed to carry the required number of working platforms and to support its live loads.

Working platforms should be constructed from either prefabricated platform units or scaffold planks.

The working platform should be wide enough to accommodate materials and plant, and allow clear and unobstructed access along its entire length.

Clear and unobstructed access should be not less than 450 mm wide, where passage is required by persons and hand tools only.

Working platforms, except suspended scaffolds should have a duty classification and dimensions complying with Table 8.7. Scaffolds designed for working platforms that support loads in excess of heavy duty should be provided with prominent signs that display the rated working load limit per platform per bay.

Working platforms should not be pitched at an angle steeper than 7° (slope of 1 to 8) to the horizontal and should have a slip-resistant surface.

Planks or decking forming the surface of a working platform should be of uniform thickness, fixed to prevent uplift or displacement in normal use and positioned to avoid significant gaps and tripping hazards.

Planks should be butted not lapped, except at returns, curved faces or unusual profiles.

Examples of unsafe working platforms are given in Figure 8.7.

## 10.6 SPUR SCAFFOLDS

The design of spur scaffolds and the adequacies of structures supporting a spur scaffold must comply with the relevant requirements of AS/NZS 1576.1. A competent person, such as an engineer experienced in structural design, must verify such a design before the spur scaffold is handed over for use.

Spurs should be pitched at an angle not exceeding 45 degrees from the vertical.

Spurs in compression that exceed 2 m in length should be secured at midspan to prevent deflection in any direction.

Spurs should be fixed to ledgers or transoms with right-angle couplers and provided with check couplers. Swivel couplers should not be used.

A single set of spurs should not support more than five lifts.

## 10.7 CANTILEVERED SCAFFOLDS

The design of cantilevered scaffolds and the adequacies of their supporting structures must be verified for compliance with the relevant requirements of AS/NZS 1576.1 by a competent person, such as an engineer experienced in structural design.

Needles should be secured by through-bolting, cast-in inserts or propping. Steel beams used as needles should have a width of not less than 75 mm and be fixed with their greater dimension vertical. Where practical, the inboard portion of the needle should be at least three times the length of the outboard portion.

Bolts and threaded rods used to secure the inboard portion of the needle should have a diameter of not less than 15 mm and lock nuts to prevent any loosening from vibration.

Where reveal props are used to secure the inboard portion of needles, at least two rows of vertical members should be used with the rows tied longitudinally and transversely. They should be braced to form an independent framework, with the props secured over the beams with fork-heads or other suitable means to prevent dislodgment (see Figure 10.7).

Scaffold planks should be laid directly on the outboard portion of the needles, to provide a platform for the scaffolder to commence erecting the scaffold.

The standards should be secured over the needles with fork-heads or other suitable means to prevent dislodgment.

A lift of ledgers and transoms should be constructed as close to the needles as possible.

A protection deck should be left in place either directly on the needles or on the base lift. When the deck is on the needles, the planks should be held captive by lashing, spiking, cleating or other suitable means.

---

## Scaffold Advanced Level

AS/NZS 4576:1995

68

Beam clamps, trolleys and shackles should have a rated working load limit of not less than 500 kg.

Standards may include:

- Scaffold tubes in single lengths.
- 6 × 24 flexible steel-wire rope slings with a nominal diameter of not less than 11 mm.
- Grade T chains with a nominal diameter of not less than 8 mm.

The method of securing the standards to the supporting structure should prevent the scaffold from becoming dislodged or displaced by the scaffold swaying. Scaffold tubes used as hung standards should have check couplers immediately above the suspension points and immediately below the lowest ledgers. Steel wire rope (without eyes) used as a hung standard should be fixed to a shackle by a wedge-type socket, together with a wire-rope grip fixed to the rope tail. Alternatively, a thimble-eye splice can be made using a double-base clamp or three fist-grip rope clamps.

NOTE: Wire-rope grips should not be used to secure wire ropes that support persons or substantial loads.

Steel wire ropes or chains secured around the sharp edges of beams should be protected from damage by beam chaffers.

Ledgers supported from the eyes of slings or from shackles should be provided with a coupler on each side of each support point, to prevent the ledger from sliding. Pins of shackles should be moused, to prevent inadvertent unwinding.

## Appendix E - Harness Inspection Checklist

<b>Fall-Arrest Checklist</b>		Date:	
Company Name:		Site:	
Harness ID Number:		Person Performing Inspection:	
Item to be checked:	Defects to Check For	✓	✘
<b>Webbing</b>	<ul style="list-style-type: none"> <li>▶ Cuts or tears.</li> <li>▶ Abrasion damage.</li> <li>▶ Excessive stretching.</li> <li>▶ Damage due to contact with heat, corrosives or solvents.</li> <li>▶ Deterioration due to rotting, mildew, or ultraviolet exposure.</li> </ul>		
<b>Snap Hooks</b>	<ul style="list-style-type: none"> <li>▶ Distortion of hook or latch.</li> <li>▶ Cracks or forging folds.</li> <li>▶ Wear at swivels and latch pivot pin.</li> <li>▶ Open rollers.</li> <li>▶ Free movement of the latch over its full travel.</li> <li>▶ Broken, weak or misplaced latch springs.</li> <li>▶ Free from dirt or other obstructions, e.g. rust.</li> </ul>		
<b>D-Rings</b>	<ul style="list-style-type: none"> <li>▶ Excessive 'vertical' movement of the straight portion of the D-ring at its attachment point of the belt, so that the corners between the straight and curved sections of the D become completely exposed.</li> <li>▶ Cracks, especially at the intersection of the straight and curved portions.</li> <li>▶ Distortion or other physical damage of the D-ring.</li> <li>▶ Excessive loss of cross-section due to wear.</li> </ul>		
<b>Buckles &amp; Adjusters</b>	<ul style="list-style-type: none"> <li>▶ Distortion or other physical damage.</li> <li>▶ Cracks and forging laps where applicable.</li> <li>▶ Bent tongues.</li> <li>▶ Open rollers.</li> </ul>		
<b>Stitching</b>	<ul style="list-style-type: none"> <li>▶ Broken, cut or worn threads.</li> <li>▶ Damage or weakening of threads due to contact with heat, corrosives, solvents or mildew.</li> </ul>		
<b>Fault Report:</b>			
<p>.....</p> <p>.....</p> <p>.....</p>			
<p>Harness isolated from service? Yes / No</p>			

## Appendix F – Handover Certificate

<b>Handover Certificate</b>		Handover Date:			
		Handover Time:			
Client Name:		Contact Name:			
Worksite Address:		Scaffold Location on Site:			
Type of Scaffold:	<input type="checkbox"/> Tube & Coupler <input type="checkbox"/> Frame / Tower Frame <input type="checkbox"/> Modular / Other (note type)				
Duty Category (Please Circle)	Light	Medium	Heavy	Special	
Number of Lifts:			Height of Scaffold:		
Number of Bays:			Length of Scaffold:		
Type of Access:	<input type="checkbox"/> Ladder <input type="checkbox"/> Stair <input type="checkbox"/> Ramp <input type="checkbox"/> Other		Design Reference Number:		
<b>NOTES:</b>					
Name of Person Responsible:					
Signature of Person Responsible:					

## Appendix G – Supplementary Information

### Increased First Lift Height

Where it becomes necessary (e.g. for pedestrian access, covered ways and gantries or similar situations) to increase the first lift height, the scaffold shall comply with the following requirements:

- A. Double standards shall extend to the second lift.
- B. The longitudinally adjacent pairs of double standards shall be joined at approximately the mid-height of the first lift with horizontal tubes connected with right-angle couplers.
- C. Each pair of double standards shall be fixed at the quarter points of the first lift with short tubes and right-angle couplers or with purpose-designed parallel couplers.
- D. The first lift height shall not exceed 3mtrs.



## Spur Scaffolds

Right angle couplers (90°) must be used to install spurs.

There are two methods of fixing Spurs (Struts or Braces) in a scaffold.

### Method A: Spurs in Compression

Fix the upper transom to the puncheons over the opening. This transom should be positioned sufficiently high enough above the ledgers over the opening and hard up under the ledgers, to give the spur the correct angle. (45°)

Fix the two lower transoms, one on each side of the opening, to the standards on each side of the opening. These transoms are positioned on top of the ledgers above the opening and hard down on same. The transoms are to be on the "opening" side of the standards. This provides for the spur to "push" the transom against the standards whereas if the transom was on the other side of the standards the right angle coupler securing the transom to the standards would be in tension.

Secure the spurs as shown in the Figure with the lower end of the strut on top of the transom and the upper end under the transom.

Fix safety fittings immediately below the upper right angle couplers securing the tops of the spurs and immediately above the right angle couplers securing the bottom of the spurs.

### Method A: Spurs in compression

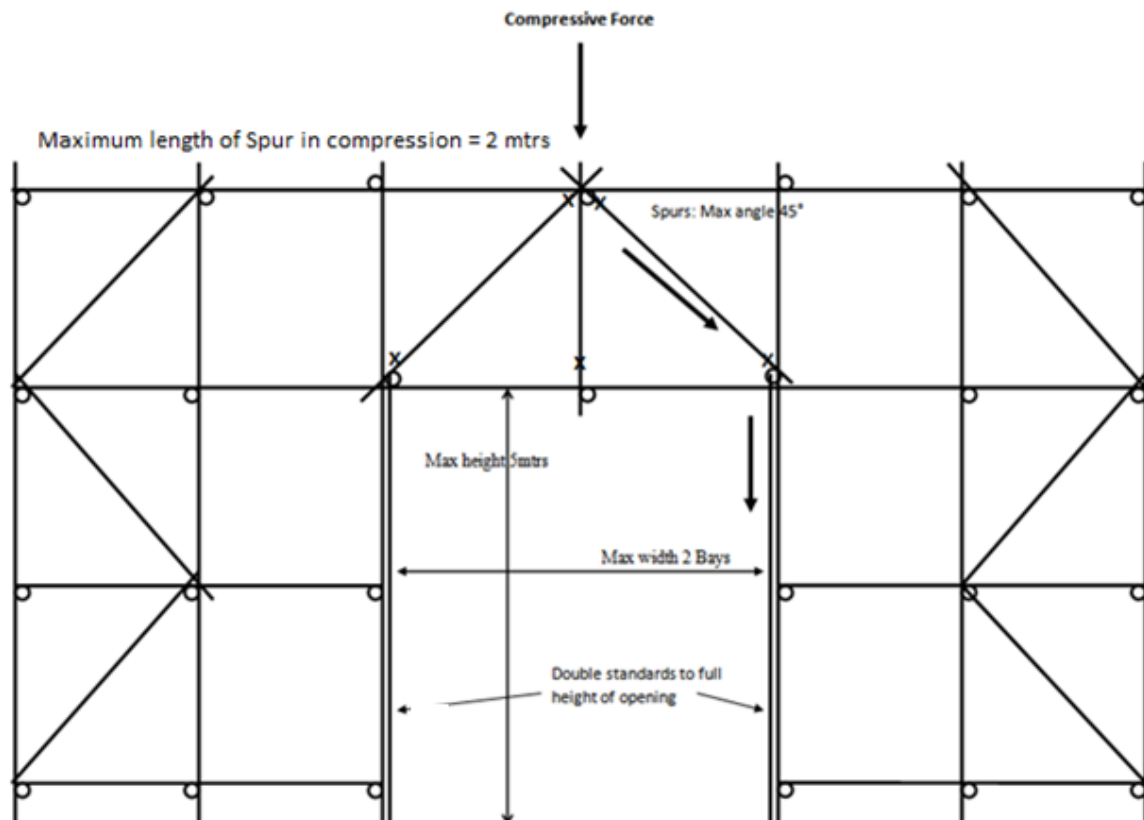

**A competent person such as an intermediate scaffolder or an engineer must verify the safety/security of the scaffold prior to the scaffold being handed over for use.**

### Method B: Rakers in Tension

Fix the lower transom to the ends of the puncheons projecting below the ledgers over the opening as shown in the figure.

Fix the two upper transoms, one on each side of the opening, to the standards on either side of the opening. These transoms are positioned above the ledgers and sufficiently high enough to give the spur the correct angle. These transoms should also be positioned on the side of the standard remote from the "opening". This provides for the spur to pull the upper transoms down on the ledger and against the standard. If the transoms were in the other side, that is the "opening side" of the standard, then the right angle coupler securing the transoms would be in tension.

Secure the rakers as shown in the figure with the upper end of the raker onto the transom and the lower end under the transom.

### Method B: Rakers in Tension

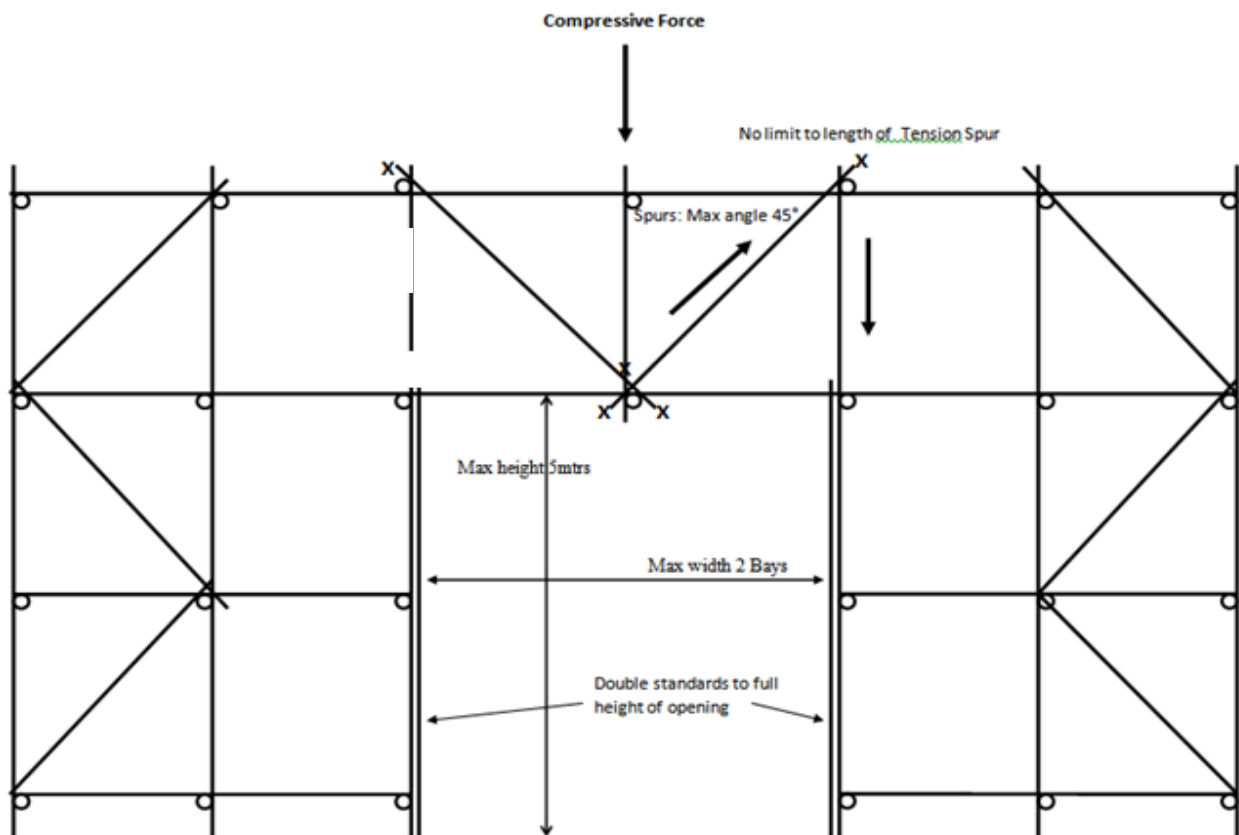

Fix safety fittings immediately above the right angle couplers securing the tops of the spurs and immediately below the right angle couplers securing the bottom of the spurs.

- ▶ Where it is necessary to omit transverse bracing in the first lift, the height of the scaffold shall not exceed 30mtrs.

The puncheons are fixed to the ledgers in the centre of the opening. The puncheons should not extend more than 75mm below the ledgers over the opening.

Struts should not be inserted in the opening as this reduces the size of the opening and the struts could be in the way if a vehicle with a high load is required to pass through the opening.

## AS/NZS 1576.6: 2000 5.4 Sloping Working Platforms

**The maximum slope of working platforms shall be in accordance with AS 1576.1 is 3° or 1:8**

Where it is necessary to provide sloping working platforms, the scaffold shall comply with the following requirements:

- A. The ledgers supporting the sloping platform shall be fixed to the upper surface of transoms with right-angle couplers.
- B. To prevent creep, the planks shall be fixed by –
  - i. lashing to the putlogs
  - ii. fixing cleats to their underside, hard against a putlog; or
  - iii. other suitable means.
- C. The guardrails and midrail shall be fixed to the standards with swivel couplers.
- D. Where there are further lifts above the sloping platform, the lift immediately above the sloping shall provide adequate head clearance along the full length of the sloping platform.

### 5.5 ACCESSWAYS AND BARROW RUNS

#### 5.5.1 General

Access ways and barrow runs shall comply with the requirements for heavy duty working platforms, except that the platform may be reduced to -

- A. 450mm, where passage is required for persons only
- B. 675mm where passage is required for wheelbarrows

#### 5.5.2 Slope

The slope of access ways shall not be more than a rise of 1:3 horizontal.

The slope of barrow runs shall not be more than a rise of 1:6 horizontal.

Where access way or a barrow run has a slope of more than a rise of 1:8 horizontal, it shall be fitted with cleats complying with clause 5.5.3

#### 5.5.3 Cleats

Cleats shall be -

- A. Nominally 25mm thick
- B. Nominally 50mm wide
- C. Spaced at intervals of nominally 450mm
- D. Fitted across the full width of the access way or barrow run, except for a gap of 100mm in the centre of barrow runs for the use by the wheel of barrows; and
- E. Nailed, screwed or otherwise securely fixed to the upper surface of the platform.

## Ramps

Ramps and sloping scaffold platforms are required at times and it is essential that the scaffold know the correct method and the fittings to be used.

Where a ramp is used as a means of access or egress, it shall be not less than 450mm in width. This width is extended to 900mm for barrows.

The slope of a ramp is not to exceed one vertical to four horizontal and where a continuous ramp is to be used for carrying material or for wheeling barrows the slope length is no to exceed 3.6 mtrs unless broken by a horizontal landing at least 1.2mtrs in length.

In erecting ramps, the variations from normal erection procedures are that the sloping ledgers are secured to the transoms with right angle couplers while the guard rails are fixed with swivel couplers. The following figure shows the construction of a typical barrow ramp.

### BARROW RAMP

- ▶ Slope shall not exceed one (1) vertical to four (4) horizontal.
- ▶ Maximum length not to exceed 3.6mtrs unless broken by a horizontal landing 1.2mtrs in length.
- ▶ Maximum spacing of standards no to exceed 1.8mtrs.
- ▶ Maximum horizontal spacing of rows of standards not to exceed 1.35mtrs.
- ▶ Putlogs to be positioned not more than 230mm from standards.
- ▶ Sloping ledgers attached to transoms with right angle couplers.

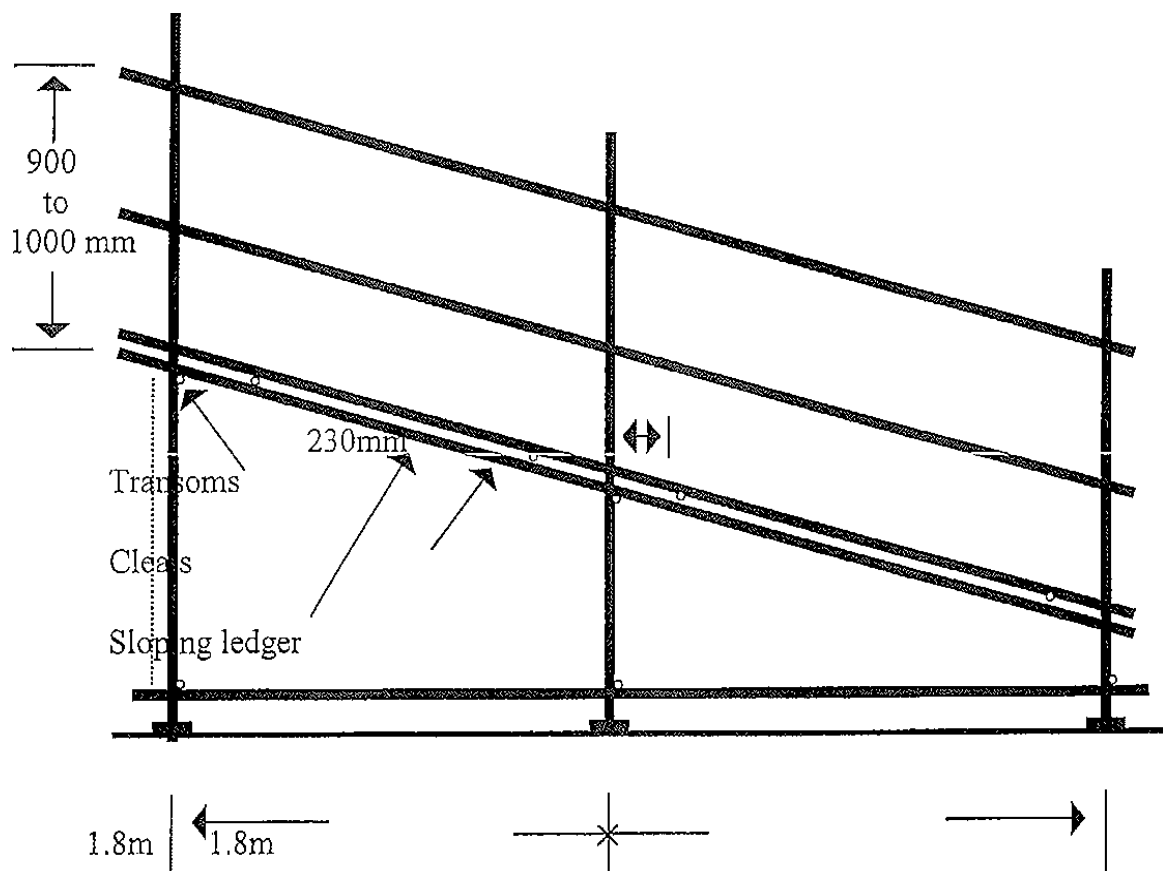

## Cantilevered Catch Platform (Fan)

Where a fan is fixed to an independent scaffold, it shall comply with the following requirements:

- a) The sloping putlogs shall be fixed with right-angle couplers to the underside of an additional ledger fixed to the inner row of standards and shall be fixed with right-angle couplers or putlog couplers to the upper side of an additional ledger fixed to the outer row of standards,
- b) The sloping putlogs shall be fixed at an angle not greater than 60° to the vertical.
- c) The sloping putlogs shall be positioned approximately 150mm on either side of each standard and at intermediate intervals not exceeding 600mm.
- d) A ledger shall be fixed with right-angle couplers to the ledger at the outermost point of the sloping putlogs and to the ledger fixed to the outer row of standards in the lift below.
- e) A ledger shall be fixed with right-angle couplers at the mid span of spurs and in each bay a tube shall be fixed with right-angle couplers to this ledger and to the nearest ledger supported by the outer row of standards.
- f) The catch platform supported by the sloping putlogs shall not exceed 1.125mtrs in width in the horizontal plane.
- g) The scaffold shall be fully decked at the level of the protective fan and any gaps between such deck and the protective fan shall be covered with securely fixed plywood or other suitable material.
- h) An additional level of tics shall be provided in immediate proximity to the fan construction.



**TUBE ARRANGEMENT FOR CANTILEVERED CATCH PLATFORM**

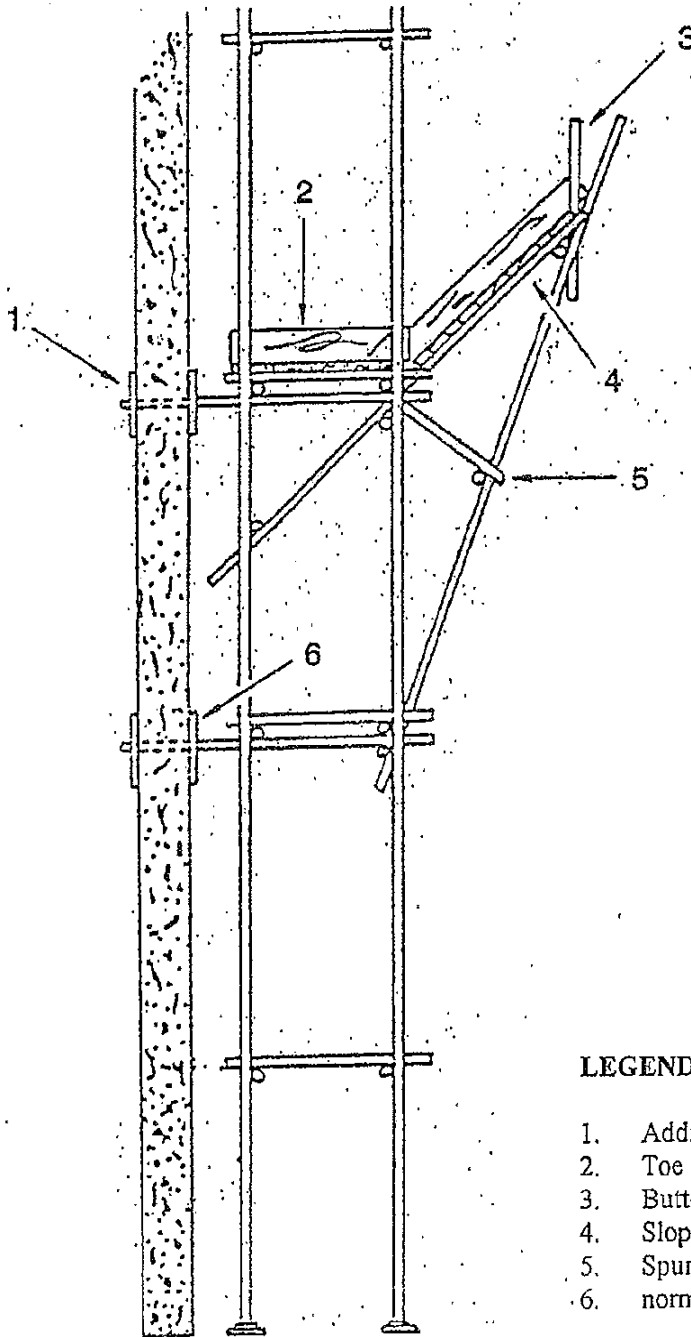

**LEGEND**

1. Additional tie
2. Toe board
3. Butt-tube to support toe board
4. Sloping putlog
5. Spur tied at midspan
6. normal tie

## Cantilevered Scaffolds

The design of cantilevered scaffolds and the adequacies of their supporting structures and when any type of drilled and anchor is to be used they must be verified for compliance with the relevant requirements of AS/NZS 1576.1 by a competent person, such as an engineer experienced in structural design.

Needles should be secured by through-bolting, cast-in inserts or propping. Steel beams used as needles should have a width of not less than 75mm and be fixed with their greater dimension vertical. Where practical, the inboard portion of the needle should be at least three times the length of the outboard portion.

Bolts and threaded rods used to secure the inboard portion of the needle should have a diameter of not less than 15mm and lock nuts to prevent any loosening from vibration.

Where reveal props are used to secure the inboard portion of needles, at least two rows of vertical members should be used with the rows tied longitudinally and transversely. **They should be braced to form an independent framework, with the props secured over the beams with fork-heads/U-heads** or other suitable means to

prevent dislodgment.

Scaffold planks should be laid directly on the outboard portion of the needles, to provide a platform for the scaffolder to commence erecting the scaffold.

The standards should be secured over the needles with fork-heads or other suitable means to prevent dislodgment.



**A lift of ledgers and transoms should be constructed as close to the needles as possible.**

A protection deck should be left in place either directly on the needles or on the base lift. When the deck is on the needles, the planks should be held captive by lashing, spiking, cleats or other suitable means.

The scaffold should be tied to the building or structure at the first lift above the base lift.

