

SITE DEVELOPMENT PLAN

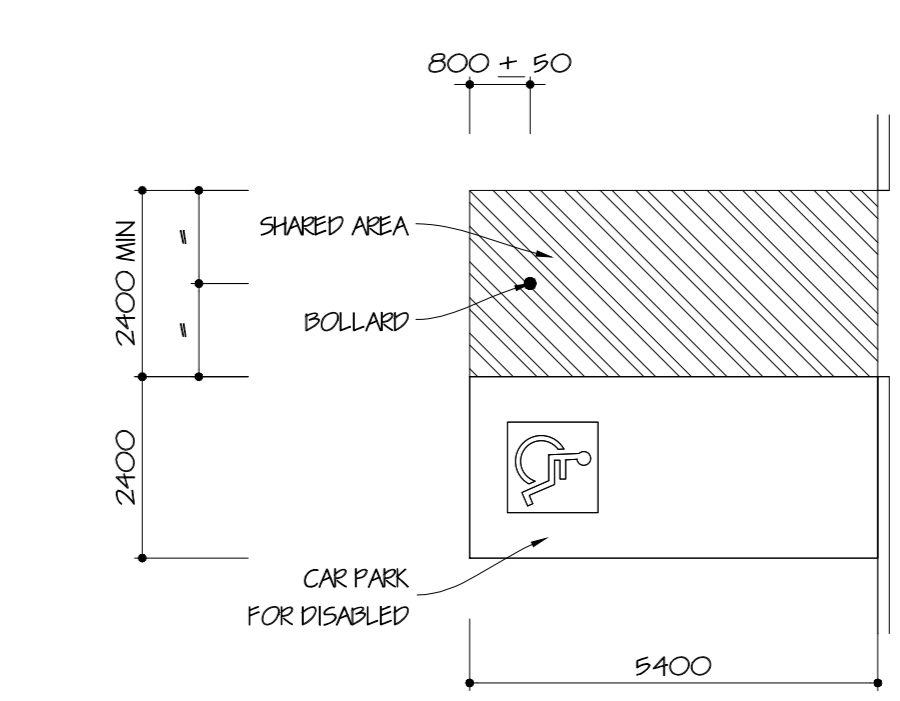

TYPICAL CAR PARK FOR DISABLED DETAIL
(Scale 1:100)

NOTE:
EXTENT OF 2000 x 2500 SIGHT TRIANGLE
TO BE IN ACCORDANCE WITH AS 2890.2:2002, FIGURE 3-4
SITE TRIANGLE TO BE KEPT CLEAR OF VISUAL OBSTRUCTIONS.
ANY LANDSCAPING WITHIN SITE TRIANGLES TO BE MAXIMUM OF
900mm IN HEIGHT AT MATURE GROWTH LEVEL.

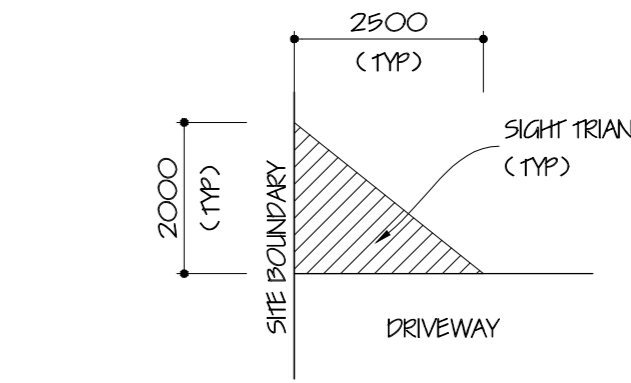

TYPICAL LINE OF SIGHT TRIANGLE DETAIL
(Scale 1:100)

MARKETING AREAS:

SITE AREA	3852 m ²
BUILDING FOOTPRINT	
TYPE 1	793 m ²
TYPE 2	396 m ²
TYPE 3	320 m ²
TYPE 4	517 m ²
GF OFFICE	84 m ²
PF OFFICE	84 m ²
TOTAL:	2194 m ²

- CARPARKS: 11 OFF
- ALL CARPARKS TO BE 2600 W x 4900 L MIN
 - CARPARKS FOR DISABLED TO BE 2400 W x 5400 L MIN WITH 2400 W SHARED PATHWAY
 - ALL DRIVEWAYS & CARPARKS TO HAVE 150mm THICK REINFORCED CONCRETE
 - PATHWAYS TO BE CONCRETE PAVED UNLESS OTHERWISE NOTED
 - RAMPS FOR DISABLED TO COMPLY WITH AS 1428.1 - 2009
 - ALL LEVELS TO AFD

- DISABLED SIGNAGE TO COMPLY WITH BCA D5.6 AND AS 2890.6-2009
- EXTENT OF PATHWAY, SHARED AREA AND CIRCULATION SPACE FOR DISABLED
- 150 WATT METAL HALIDE FLOOD LIGHT TO BE BAFFLED TO LIMIT LIGHT SPILL BEYOND SITE BOUNDARIES

PRELIMINARY ISSUE
NOT FOR CONSTRUCTION

REVISION	

All levels and dimensions in this document are copyright and its supplied on the condition that it is not to be used by any other person without the prior permission of Stephen D'Andrea Pty. Ltd.

STEPHEN D'ANDREA PTY. LTD.
A.C.N. 005 676 588
SUITE 9 / 84 - 90 LAKEWOOD BOULEVARD
BRAESIDE 3195
TELEPHONE 9587 5000
FAX 9588 2020
MOBILE (0418) 314 021
EMAIL design@stephendandrea.com.au
WEB SITE www.stephendandrea.com.au

PROJECT
PROPOSED STORAGE & OFFICE
AT LOT 12 MULCAHY ROAD,
PAKENHAM.

CLIENT

DATE	JUNE '20	SCALE	1:200
DRAWN	1N	SHEET	1 OF
DRG No	6126/20	AO	ISSUE

