

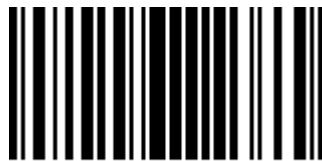

Zodiac Underwater Niche Lights for Concrete Pools

INSTALLATION AND OPERATING INSTRUCTIONS



14227

A division of

FLUIDRA





For full warranty terms and conditions and to register your warranty, simply visit www.zodiac.com.au/warranty and complete your details. Or scan the QR code and be taken directly to the registration page



Record your Equipment details here for quick reference:

Model No.: _____

Serial No.: _____

INSTALLATION FOR CONCRETE POOLS

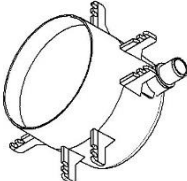
Kit Contents

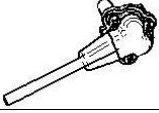
Quantity	Item	
1	75810-C Concrete Niche Assembly	
1	75811 Mounting Ring	
1	20348 Cable - Lumipower Light 20m, or 20344 Cable - Lumipower Light 35m	
1	26938 Foam insert 147mm diameter (fits niche)	
1	26939 Foam insert 136mm diameter (fits mounting ring)	

Installation Instructions

Please note that the first few steps of these instructions must be performed before the concrete is poured. Once poured, the remainder of the steps can then be taken.

1. Using soft wire or cable ties, attach the niche (item 75810-C) to the steel reinforcement. The conduit inlet should be directed upwards as depicted. For servicing and practical reasons, the light should not be installed deeper than 450mm below the water line. Install the niche so its front face will be flush with the inside face of the finished concrete wall.

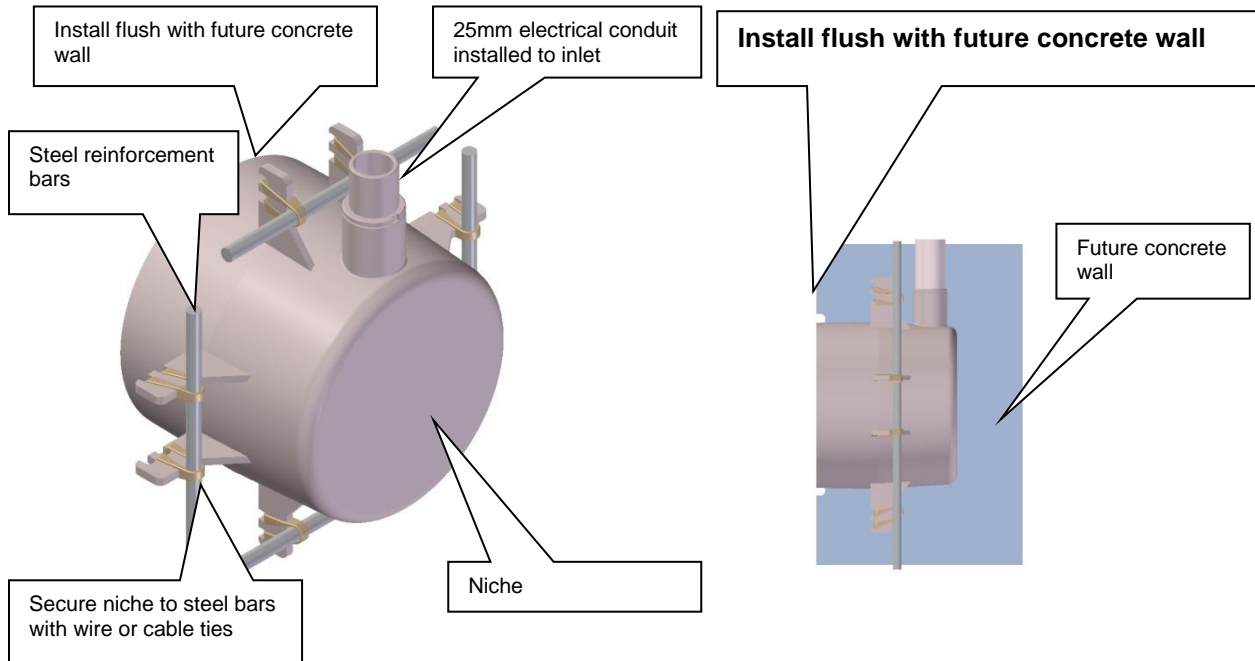

2. Glue a length of 25mm electrical conduit to the niche conduit socket using PVC solvent cement. Ensure the conduit extends above the water level of the pool. If a draw wire is not being used, the cable (item WT000268 or WT000269) must be fitted simultaneously with the conduit installation. Starting at the niche, run the cable through the conduit to the power supply. Leave 1m of cable surplus inside the niche, complete with the end of the cable with the plug, and coil up inside the niche until ready to fit the light. Ensure the cable gland inside the niche is fully tightened around the cable.

3. Install a second conduit to return below ground level and away to the power supply. Both conduits should be glued into a draw box to allow for future service.

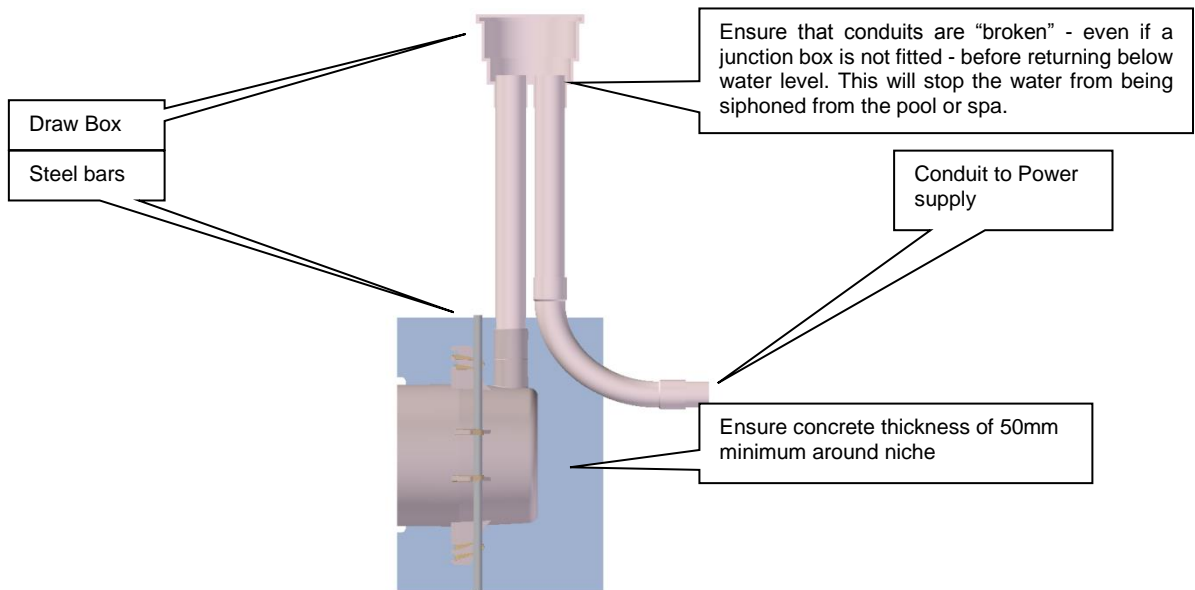

4. Press the larger polystyrene foam insert (item 26938) into the niche's front opening. This temporary insert will stop dirt, concrete and debris entering the niche and will maintain roundness of the niche under the weight of the concrete. The foam insert must be a tight fit inside the niche.
5. Cover the entire niche surface with concrete in a uniform manner to ensure secure fixing. Ensure the concrete covers the niche all around and at the back – air pockets and bubbles in the concrete must be eliminated. Avoid creating thin sections of concrete to minimise the risks of cracking or leaks. It is imperative the front edge of the niche does not stand proud of the concrete or sit recessed to the concrete. Ensure there is at least 50mm of concrete behind the niche.
6. Smooth the concrete around the niche and make a recess around the rim of approximately 8mm, to allow for installation of a waterproof seal.

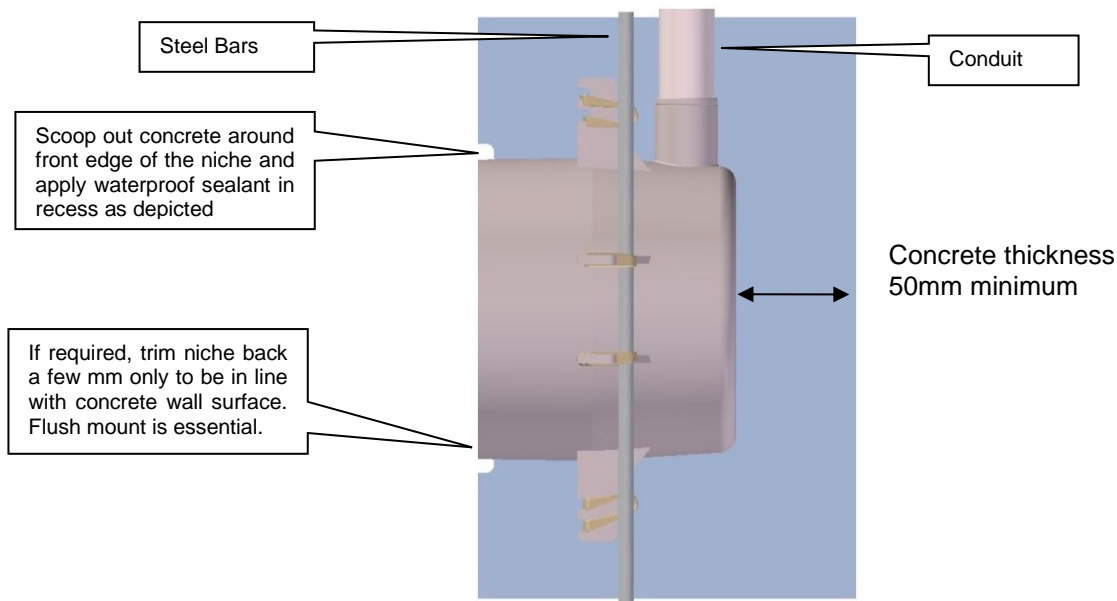

7. When the concrete has dried, remove the foam cover from the niche. Fill the recess around the niche with a waterproof sealant (2 part epoxy). Keep the sealant flush with the niche front edge and concrete wall surface.
8. To install the light mounting ring into the niche:
 - a. Apply PVC cement to the swivel surface of the mounting ring (item 75811) and also to the inside of the niche where the mounting ring is likely to rest (approx. 20mm inside niche).
 - b. For easier installation and maintenance of the light, it is highly recommended that the mounting ring be installed according to the following description. The mounting ring has a large "X" mark that should be installed into the niche such that the marker is at the 12 o'clock position. Please see the following image, which highlights the marker and its correct position. Press the mounting ring into the niche, with the marker at 12 o'clock, until the ring sits flush against the pool concrete wall. Check for correct installation before the glue sets.

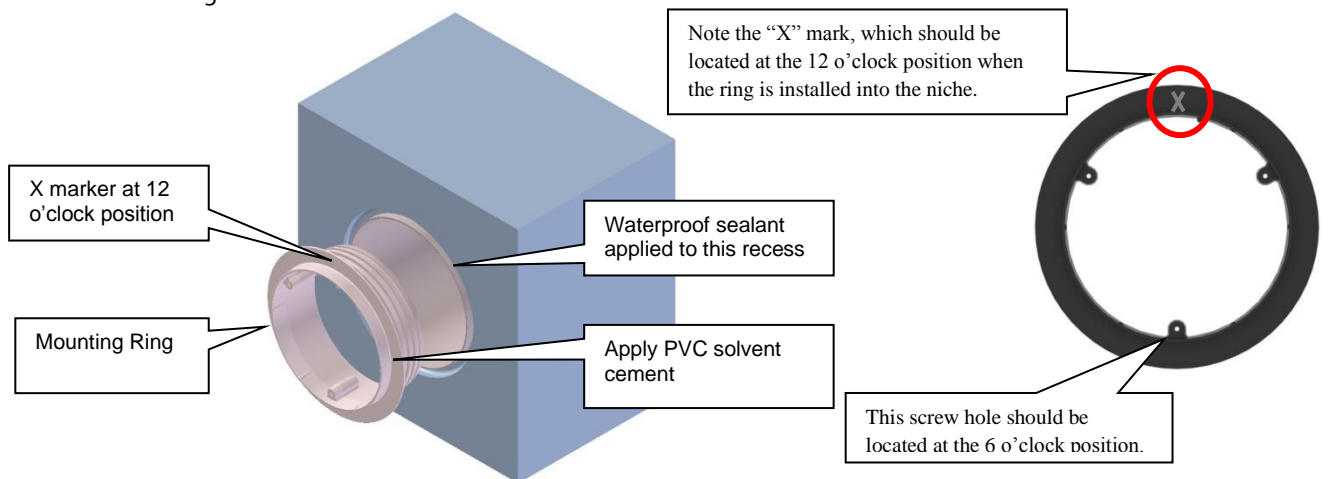

9. Press the second, smaller polystyrene foam cover (item 26939) into the mounting ring. This will prevent dirt and debris entering the niche during rendering or tiling and will also help maintain roundness under the weight of the tiles.
10. Now apply the render or tiles, ensuring that the finished tile/render surface is level with the front edge of the mounting ring.

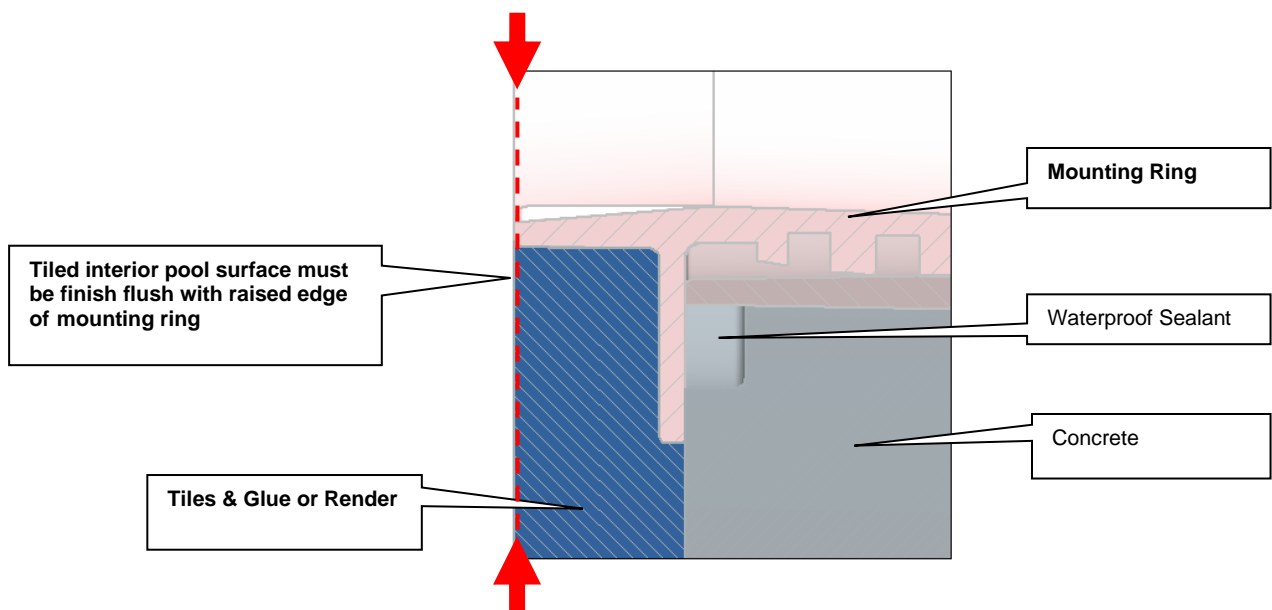

ATTENTION: Interior pool surface must finish flush with the raised edge of the mounting ring, or it will not be possible to properly install the light.

ATTENTION: Do not install the light until the pool has been washed with acid.

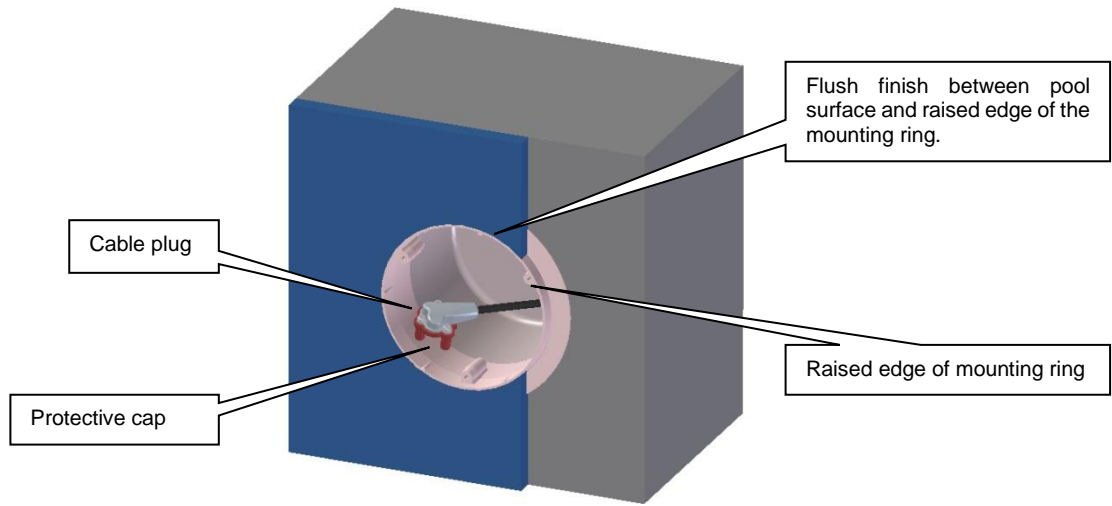



Zodiac is a registered trademark of Fluidra Group Australia Pty Ltd
ABN 87 002 641 965

CUSTOMER SERVICE CENTRE
Fluidra Group Australia
219 Woodpark Rd, Smithfield,
NSW. 2164 Australia